

SAMSON

SAMSON SED

CATALOG



Manual Diaphragm Valve DN 15-100

PVC-U / PVC-C / PP-H / PVDF / ABS

TABLE OF CONTENTS

Type 286 - DN 12-15 (MA 10)	04
General information - Technical specification	04
Sectional view	05
Technical data	06
Dimensions	07 - 09
Exploded view - Components - Part list	10
Assembly - Disassembly - Installation	11
Type 882 - DN 15-65 (MA 20-50)	12
General information - Technical specification	12
Sectional view	13
Technical data	14 - 15
Dimensions	16 - 20
Accessories	20
Fastening - Supporting - Customization	21
Exploded view - Components - Part list	22
Assembly - Disassembly - Installation	23 - 24
Adjustment	25
Type 885 - DN 80-100 (MA 80-100)	26
General information - Technical specification	26
Sectional view	27
Technical data	28
Dimensions	29 - 30
Exploded view - Components - Part list	31
Assembly - Disassembly - Installation	32
Ordering key	33
Overview product range	34

MATERIAL AND BODY END CONNECTIONS

Type	DN	Female ends, BSP threaded, code 1	Female ends, metric series, code 2	Female union ends, metric series, code 30	Female union ends, BS series, code 31	Female union ends, ASTM series, code 32	Female union ends, BSP threaded, code 33	Male ends, metric series, code 39	Fixed flanges, drilled PN10/16, code 81	Fixed flanges, drilled ANSI B16.5 cl. 150 #FF, code 88
------	----	-----------------------------------	------------------------------------	---	---------------------------------------	---	--	-----------------------------------	---	--

Valve body material: PVC-U										
286	12	P8	P7							
	15	P8	P7	P8			P9	P7		
882	15-50			P17	P19	P18	P18	P16	P19	P20
	65							P16	P19	P20
885	80-100							P29	P29	P30

Valve body material: PP-H										
286	12	P8	P7							
	15	P8	P7	P8			P9	P7		
882	15-50			P17				P16	P19	P20
	65							P16	P19	P20
885	80-100							P29	P29	P30

Valve body material: PVDF										
286	12	P8	P7							
	15	P8	P7	P8			P9	P7		
882	15-50			P17				P16	P19	P20
	65							P16	P19	P20
885	80-100							P29	P29	P30

Valve body material: PVC-C										
286	15			P8				P7		
882	15-50			P17		P18	P18	P16	P19	P20
	65							P16	P19	P20
885	80-100							P29	P29	P30

Valve body material: ABS										
882	15-50			P17						
	65							P16		
885	80-100							P29		

P = Page

TYPE 286

DN 12-15

The 286 is a manually operated diaphragm valve of reduced dimensions and particularly compact structure, ideal for use in confined spaces.

COMPACT DIAPHRAGM VALVE

- Connection system for solvent weld and threaded joints
- Extremely compact construction
- **Internal operating components in metal totally isolated from the conveyed fluid**
- Valve stem in STAINLESS steel
- **Compressor with floating diaphragm support**
- Easy to replace diaphragm seal
- Corrosion-proof internal components
- **CDSA** (Circular Diaphragm Sealing Angle) system offering the following advantages:
 - uniform distribution of shutter pressure on the diaphragm seal
 - reduction in the tightening torque of the screws fixing the actuator to the valve body
 - reduced mechanical stress on all valve components (actuator, body and diaphragm)
 - easy to clean valve interior
 - low risk of the accumulation of deposits, contamination or damage to the diaphragm due to crystallisation
 - operating torque reduction

Technical specifications	
Construction	Compact single wear diaphragm valve
Size range	DN 12-15
Diaphragm size	MA 10
Nominal pressure	PN 6 with water at 20 °C
Temperature range	PVC-U: 0 °C - 60 °C - PVC-C: 0 °C - 100 °C PP-H: 0 °C - 100 °C - PVDF: -20 °C - 120 °C
Coupling standards	Solvent welding / Welding: EN ISO 1452, EN ISO 15493, BS 4346-1, DIN 8063, NF T54-028, ASTM D 2467. Can be coupled to pipes according to EN ISO 1452, EN ISO 15493, DIN 8062, NF T54-016, ASTM D 1785 Thread: ISO 228-1, DIN 2999, ASTM D 2464, Flanging system: ISO 7005-1, EN ISO 1452, EN ISO 15493, EN 558-1, DIN 2501, ANSI B16.5 Cl.150, JIS B2220
Reference standards	Construction criteria: EN ISO 16138, EN ISO 1452, EN ISO 15493 Test methods and requirements: ISO 9393 Installation criteria: DVS 2204, DVS 2221, UNI 11242
Valve material	Body: PVC-U / PVC-C / PP-H / PVDF Bonnet and handwheel: PA-GR
Diaphragm material	EPDM, FPM, PTFE
Control options	Manual control; pneumatic actuator

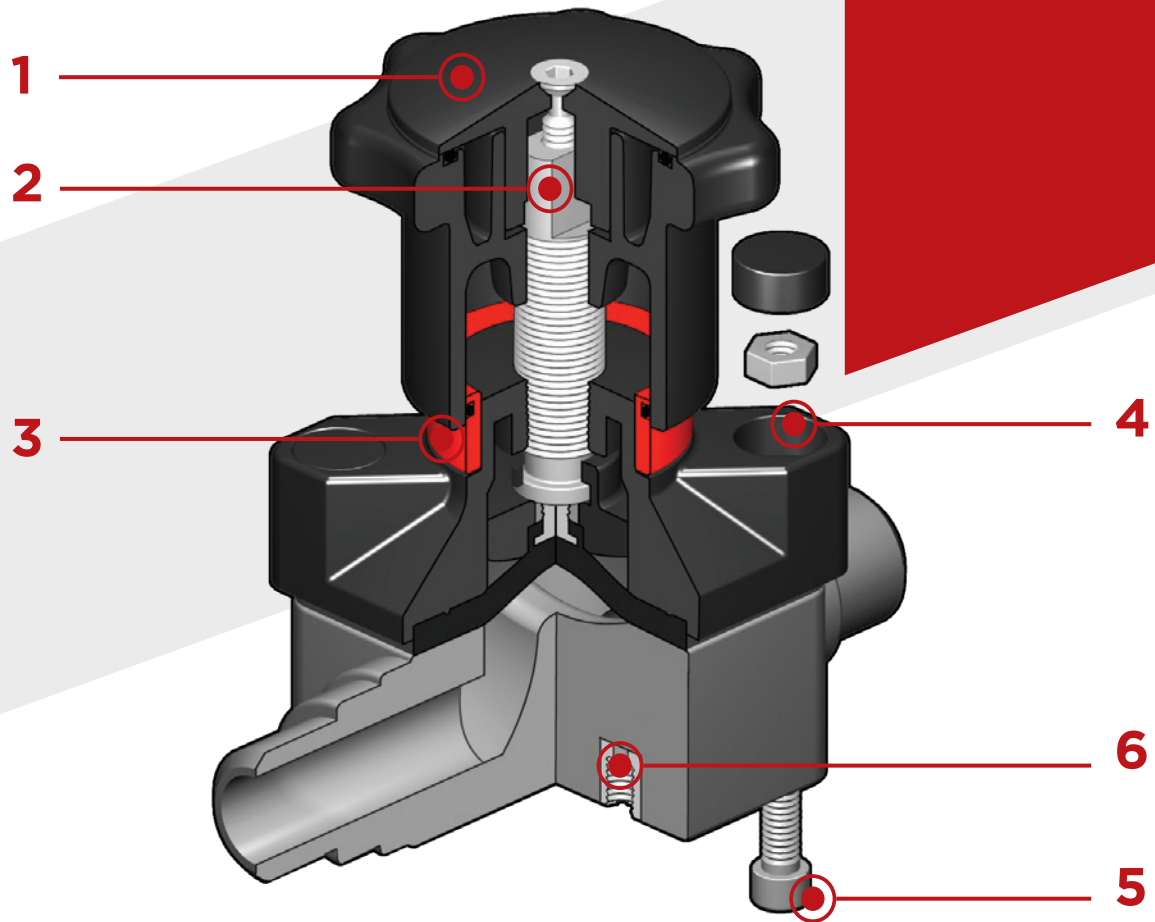

- 1 Handwheel in PA-GR, completely sealed**, high mechanical strength with ergonomic grip for optimum manageability
- 2 Integrated adjustable torque limiter** designed to prevent excessive compression of the diaphragm and always guarantee a minimum fluid flow

- 3 Optical position indicator** supplied as standard
- 4 Bonnet in PA-GR with STAINLESS steel nuts** fully protected by plastic plugs to eliminate zones where impurities may accumulate. Internal circular and symmetrical diaphragm sealing area

- 5 STAINLESS steel bolts**, can also be inserted from above
- 6 Threaded metal inserts** for anchoring the valve

TECHNICAL DATA

PRESSURE VARIATION ACCORDING TO TEMPERATURE

For water and non-hazardous fluids with regard to which the material is classified as CHEMICALLY RESISTANT. In other cases, a reduction of the nominal pressure PN is required (25 years with safety factor).

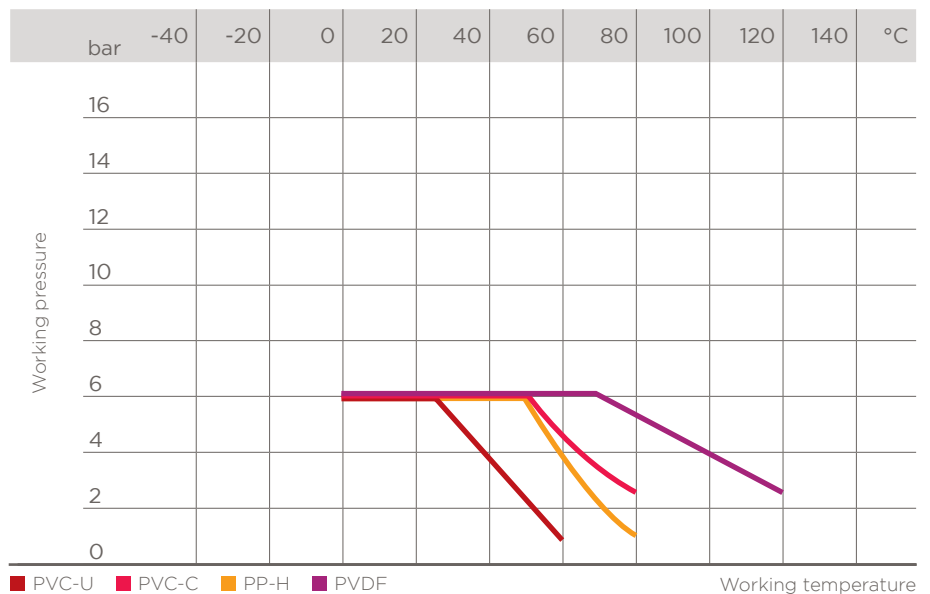

PRESSURE DROP GRAPH

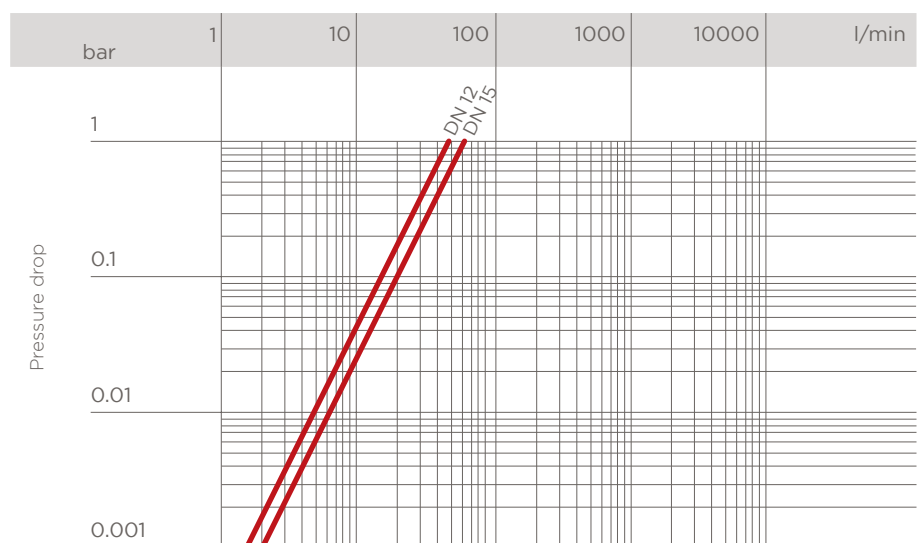

K_v100 FLOW COEFFICIENT

The K_v100 flow coefficient is the Q flow rate of litres per minute of water at a temperature of 20°C that will generate $\Delta p = 1$ bar pressure drop at a certain valve position.

The K_v100 values shown in the table are calculated with the valve completely open.

DN	12	15
K _v 100 l/min	47	60

The information in this leaflet is provided in good faith. No liability will be accepted concerning technical data that is not directly covered by recognised international standards. SED reserves the right to carry out any modification. Products must be installed and maintained by qualified personnel.

DIMENSIONS - TYPE 286

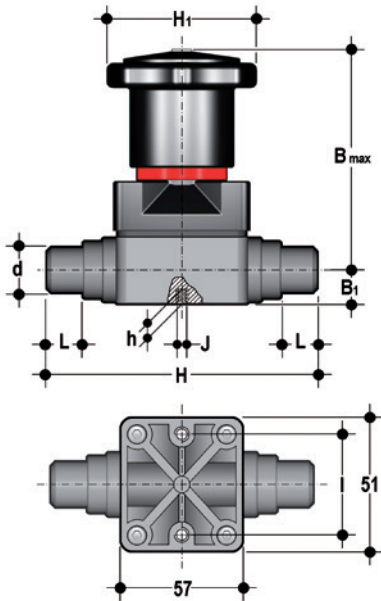

Compact diaphragm valve with **male ends** for solvent respectively socket welding, **metric series**, code 39

DN	MA	PN	B max	B ₁	d	H	h	H ₁	l	J	L	Weight (g)		
												PVC-U PVC-C	PP-H	PVDF
15	10	6	86	15	20	124	8	58.5	35	M5	17	310	260	290

Figures for PVC-U version

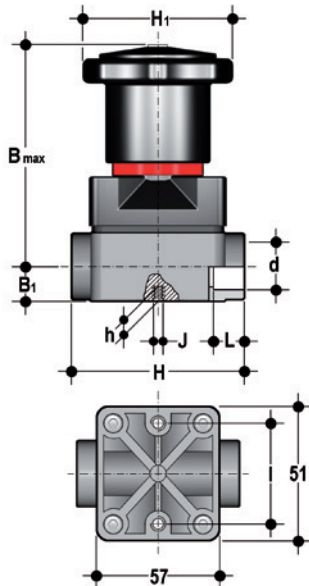

Compact diaphragm valve with **female ends** for solvent respectively socket welding, **metric series**, code 2

DN	MA	PN	B max	B ₁	d	H	h	H ₁	l	J	L	Weight (g)		
												PVC-U	PP-H	PVDF
12	10	6	86	15	16	124	8	58.5	35	M5	14	280	250	270
15	10	6	86	15	20	124	8	58.5	35	M5	16	280	250	270

Figures for PVC-U version

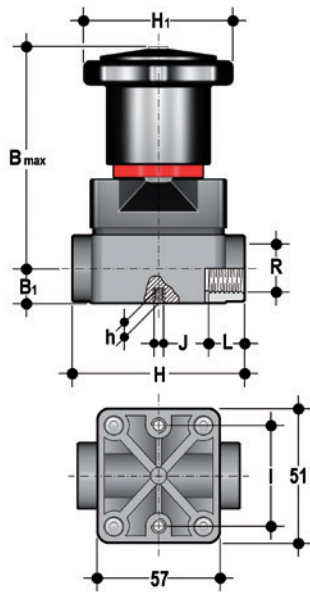

Compact diaphragm valve with **BSP threaded female ends**, code 1

DN	MA	PN	B max	B ₁	H	h	H ₁	I	J	L	R	Weight (g)		
												PVC-U	PP-H	PVDF
12	10	6	86	15	75	8	58.5	35	M5	11.5	3/8"	280	250	270
15	10	6	86	15	75	8	58.5	35	M5	15	1/2"	280	250	270

Figures for PVC-U version

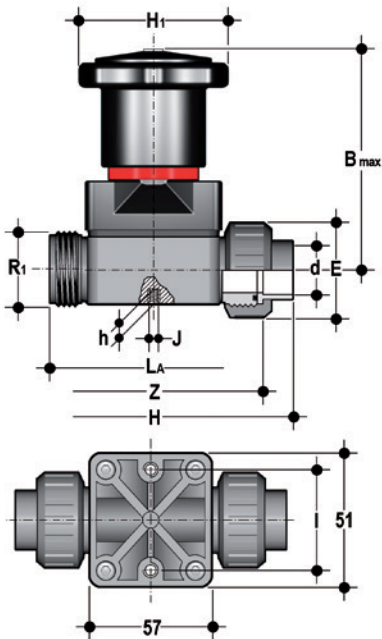

Compact diaphragm valve with **female union ends** for solvent respectively socket welding, **metric series**, code 30

DN	MA	PN	B max	d	E	H	h	H ₁	I	J	L _A	R ₁	Z	Weight (g)		
														PVC-U PVC-C	PP-H	PVDF
15	10	6	86	20	41	129.5	8	58.5	35	M5	90	1"	97.5	340	300	370

Figures for PVC-U version

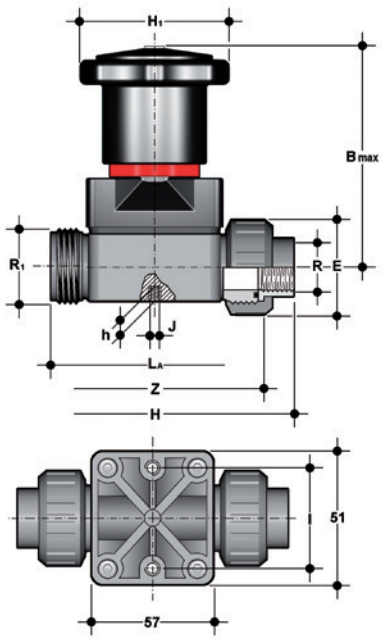

Compact diaphragm valve with **BSP threaded female union ends**, code 33

DN	MA	PN	B max	E	H	h	H ₁	I	J	L _A	R ₁	R	Z	Weight (g) PVC-U PVC-C
15	10	6	86	41	129.5	8	58.5	35	M5	90	1"	1/2"	97.5	340

Figures for PVC-U version

COMPONENTS

EXPLODED VIEW

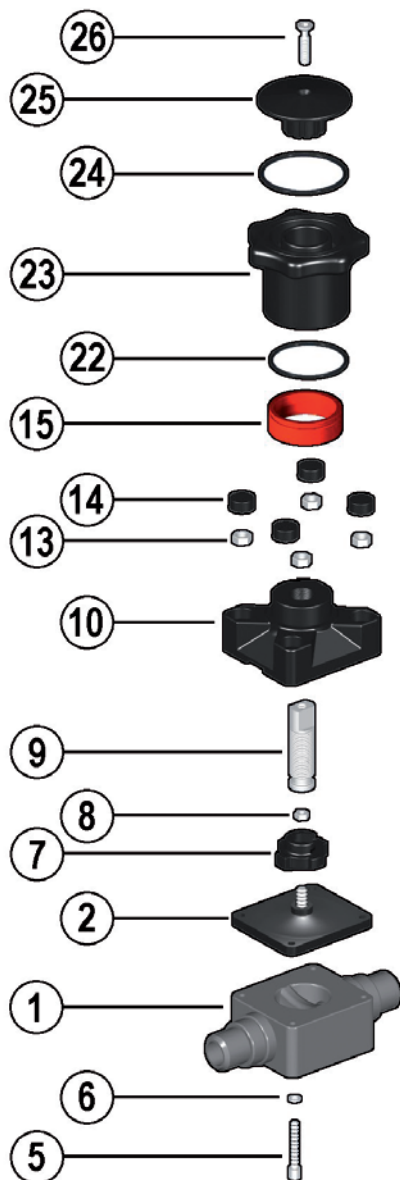

1 · Body (PVC-U - 1)

2 · Diaphragm seal
(EPDM, FPM, PTFE - 1)

5 · Fastening screw
(STAINLESS steel - 4)

6 · Washer (STAINLESS steel - 4)

7 · Compressor (PA-GR - 1)

8 · Nut (STAINLESS steel - 1)

9 · Stem (STAINLESS steel - 1)

10 · Bonnet (PA-GR - 1)

13 · Nut (STAINLESS steel - 4)

14 · Protection plug
(POM - 4)

15 · Optical position indicator
(PVDF - 1)

22 · O-Ring (NBR - 1)

23 · Handwheel (PA-GR - 1)

24 · O-Ring (NBR - 1)

25 · Bonnet (PA-GR - 1)

26 · Fastening screw
(STAINLESS steel - 1)

The material of the component and the quantity supplied are indicated between brackets

DISMOUNTING

If the valve is already installed on the line, shut-off the fluid flow upstream and make sure that there is no pressure. If necessary, fully drain the system downstream. If there are hazardous fluids present, drain and ventilate the valve.

The diaphragm constitutes the part of the valve more subject to mechanical and chemical stress from the fluid. Consequently, the condition of the diaphragm must be checked at regular intervals in accordance with the service conditions. To do this, it must be disconnected from the handwheel and from the valve body.

- 1) Unscrew the four screws (5) and separate the body (1) from the internal components.
- 2) Unscrew the diaphragm seal (2) from the shutter (7).
- 3) If necessary, clean or replace the diaphragm seal (2).
- 4) If necessary, lubricate the stem (9).

MOUNTING

- 1) The diaphragm seal (2) must be screwed fully into the compressor (7) in a clockwise direction. If necessary, unscrew slightly in an anticlockwise direction to line up the screw holes.
- 2) Fix the bonnet (10) to the body (1) using screws (5). Tighten the screws, making sure not to over-compress the diaphragm.

INSTALLATION

The valve can be installed in any position and in any direction. When starting up the plant, make sure that there are no leaks from between the diaphragm and the valve body. If necessary, tighten the fastening screws (5).

SETTING

The valve is factory set to guarantee a permanent seal without requiring any further intervention. To adjust the setting, rotate the handwheel to the required minimum opening position, remove screw (26) using a hex key.

Remove the bonnet (25) and rotate the handwheel (23) clockwise until a resistance to the rotation is felt.

If necessary, replace the O-Ring (24) in its seating and re-insert the bonnet (25) in the handwheel: the double D connection must fit over the stem (9) and, with a slight twisting action, align the ribs in the bonnet with those in the handwheel.

Tighten screw (26) to a sufficiently high torque value.

Each turn of the handwheel corresponds to 1.75mm travel.

TYPE 882

DN 15-65

The new 882 diaphragm valve is particularly suitable for shutting off and regulating abrasive or dirty fluids.

The new internal geometry of the body optimises fluid dynamic efficiency by increasing the flow rate and ensuring an optimum linearity of the flow adjustment curve.

The 882 is extremely compact and very light.

The innovative handwheel is equipped with a patented immediate and ergonomic operating locking device that allows it to be adjusted and locked in any position.

2-WAY DIAPHRAGM VALVE

- Connection system for solvent weld, threaded and flanged joints
- **Optimised fluid dynamic design:** maximum output flow rate thanks to the optimised efficiency of the fluid dynamics that characterise the new internal geometry of the body
- **Internal components in metal, totally isolated from the fluid** and external environment
- **Modularity of the range:** only 2 handwheel and 4 diaphragm and bonnet sizes for 7 different valve sizes
- Non-rising handwheel that stays at the same height during rotation, equipped with a graduated optical indicator protected by a transparent PVC cap with seal O-Ring
- Bonnet fastening screws in AISI 316 steel protected against the external environment by PE plugs. Absence of metal parts exposed to the external environment to prevent any risk of corrosion
- **CDSA** (Circular Diaphragm Sealing Angle) system that, thanks to the uniform distribution of shutter pressure on the diaphragm seal, offers the following advantages:
 - reduction in the tightening torque of the screws fixing the actuator to the valve body
 - reduced mechanical stress on all valve components (actuator, body and diaphragm)
 - easy to clean valve interior
 - low risk of the accumulation of deposits, contamination or damage to the diaphragm due to crystallisation
 - operating torque reduction

Technical specifications	
Construction	Diaphragm valve with maximized flow rate and lockable handwheel
Size range	DN 15 - 65
Diaphragm size	MA 20 - 50
Nominal pressure	PN 10 with water at 20° C
Temperature range	PVC-U: 0 °C - 60 °C - PVC-C: 0 °C - 100 °C PP-H: 0 °C - 100 °C - PVDF: -20 °C - 120 °C ABS: -20 °C - 80 °C
Coupling standards	Solvent welding / Welding: EN ISO 1452, EN ISO 15493, BS 4346-1, DIN 8063, NF T54-028, ASTM D 2467. Can be coupled to pipes according to EN ISO 1452, EN ISO 15493, DIN 8062, NF T54-016, ASTM D 1785 Thread: ISO 228-1, DIN 2999, ASTM D 2464, Flanging system: ISO 7005-1, EN ISO 1452, EN ISO 15493, EN 558-1, DIN 2501, ANSI B16.5 Cl.150, JIS B2220
Reference standards	Construction criteria: EN ISO 16138, EN ISO 1452, EN ISO 15493 Test methods and requirements: ISO 9393 Installation criteria: DVS 2204, DVS 2221, UNI 11242
Valve material	Body: PVC-U / PVC-C / PP-H / PVDF / ABS Bonnet and handwheel: PP-GR Position indicator cap: PVC
Diaphragm material	EPDM, FPM, PTFE (on request NBR)
Control options	Manual control; pneumatic actuator

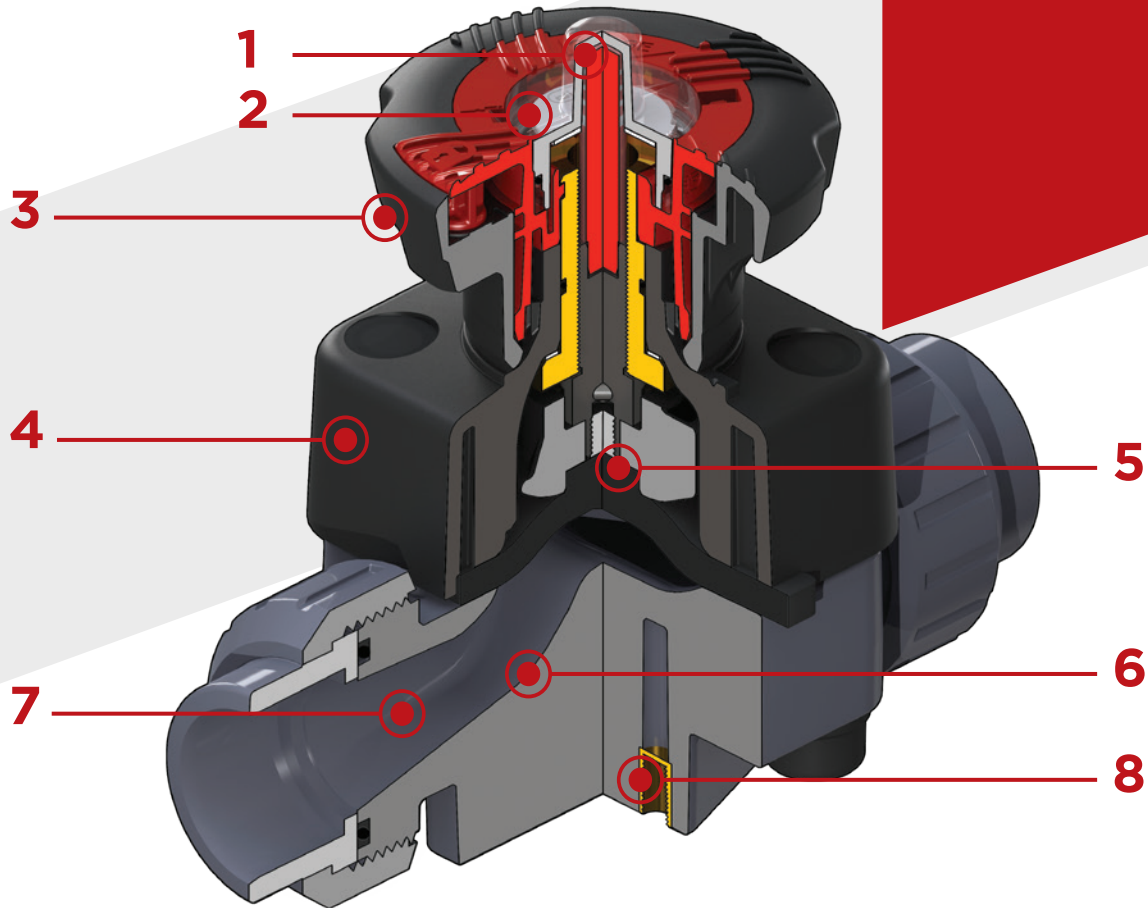

1 High visibility graduated optical position indicator protected by a transparent cap with seal O-Ring

2 Customization plate: the customization lets you identify the valve on the system according to specific needs

3 Locking system: innovative handwheel with a patented immediate and ergonomic operating locking device that allows it **to be adjusted and locked in over 300 positions**

4 Handwheel and bonnet in high mechanical strength and chemically resistant PP-GR, providing full protection by isolating all internal metal parts from contact with external agents

5 Floating pin connection between the control screw and diaphragm to prevent concentrated loads, improve the seal and extend its lifetime

6 New design of valve body interior: substantially increased flow coefficient and reduced pressure drop. The degree of efficiency reached has also enabled **the size and weight** of the valve to be reduced

7 Adjustment linearity: the internal profiles of the valve also greatly improve its characteristic curve, resulting in **extremely sensitive and precise adjustment** along the entire stroke of the shutter

8 Valve anchoring bracket **integrated in the body,** with threaded metal inserts allowing **simple panel or wall mounting** using the wall mounting plate (supplied as an accessory)

TECHNICAL DATA

PRESSURE VARIATION ACCORDING TO TEMPERATURE

For water and harmless fluids to which the material is classified as CHEMICALLY RESISTANT. In other cases, a reduction of the nominal pressure PN is required (25 years with safety factor).

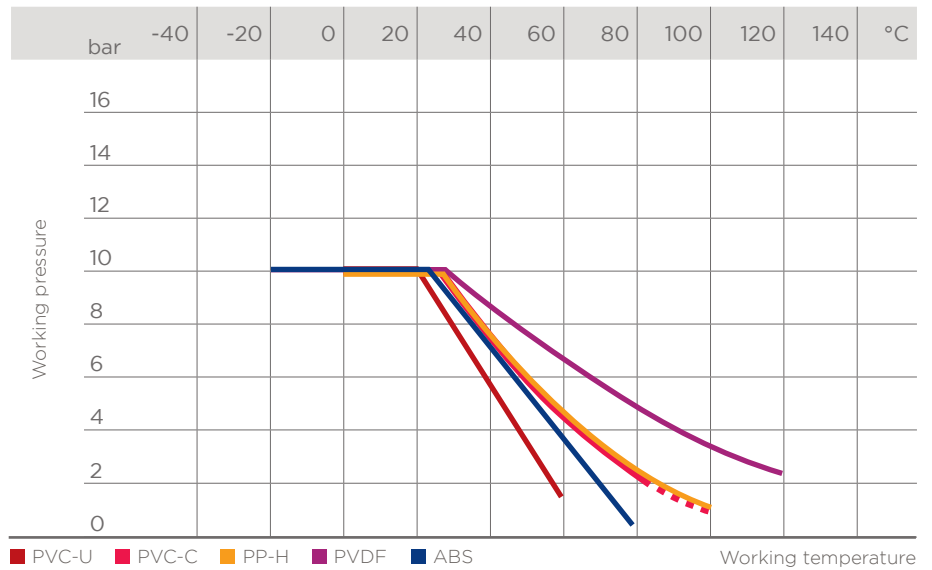

PRESSURE DROP GRAPH

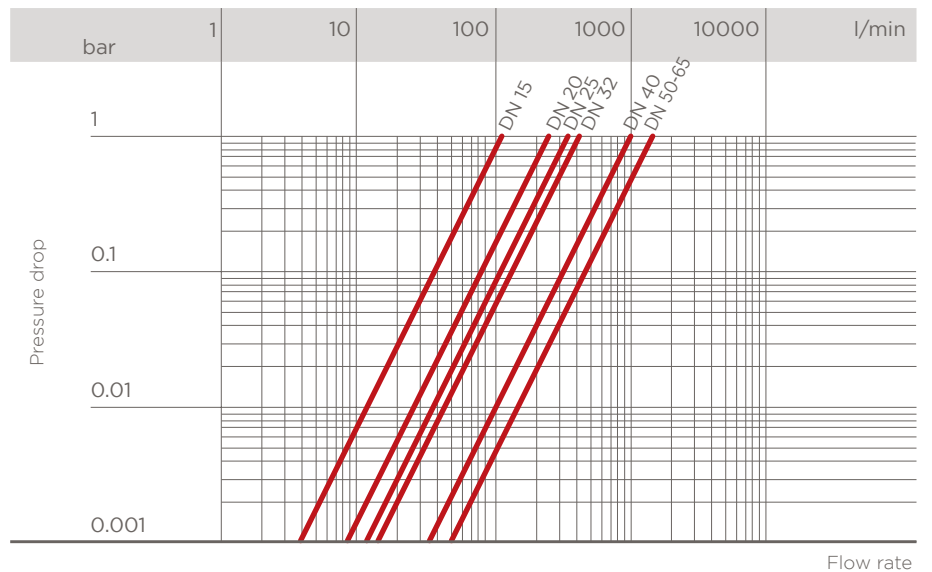

K_v100 FLOW COEFFICIENT

The K_v100 flow coefficient is the Q flow of litres per minute of water at a temperature of 20°C that will generate Δp= 1 bar pressure drop at a certain valve position.

The K_v100 values shown in the table are calculated with the valve completely open.

DN	15	20	25	32	40	50	65
K _v 100 l/min	112	261	445	550	1087	1648	1600

RELATIVE FLOW COEFFICIENT GRAPH

The relative flow coefficient refers to the variation in the flow rate as a function of the valve opening stroke.

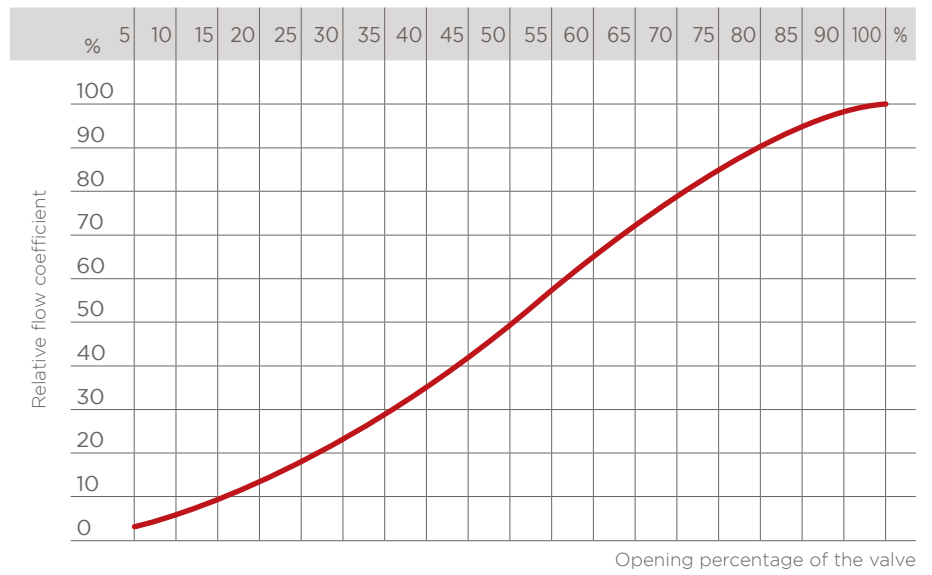

The information in this leaflet is provided in good faith. No liability will be accepted concerning technical data that is not directly covered by recognised international standards. SED reserves the right to carry out any modification. Products must be installed and maintained by qualified personnel.

DIMENSIONS - TYPE 882

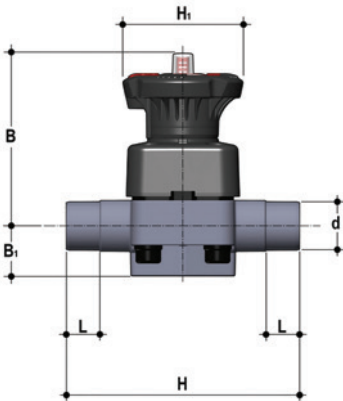

2-way diaphragm valve with **male ends** for solvent respectively socket welding, **metric series**, code 39

DN	MA	PN	B	B ₁	d	H	H ₁	L	Weight (g)		
									PVC-U / PVC-C	PP-H	PVDF
15	20	10	102	25	20	124	80	16	460	430	497
20	20	10	105	30	25	144	80	19	482	445	527
25	25	10	114	33	32	154	80	22	682	620	756
32	25	10	119	30	40	174	80	26	726	650	817
40	40	10	147	35	50	194	120	31	1525	1380	1700
50	50	10	172	46	63	224	120	38	2389	2135	2693
65	50	10	172	46	75	284	120	44	2519	2225	2871

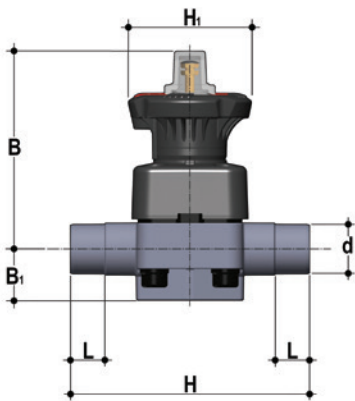

2-way diaphragm valve with **stroke limiter and male ends** for solvent respectively socket welding, **metric series**, code 39

DN	MA	PN	B	B ₁	d	H	H ₁	L	Weight (g)		
									PVC-U / PVC-C	PP-H	PVDF
15	20	10	115	25	20	124	80	16	490	460	527
20	20	10	118	30	25	144	80	19	512	475	557
25	25	10	127	33	32	154	80	22	712	650	786
32	25	10	132	30	40	174	80	26	756	680	847
40	40	10	175	35	50	194	120	31	1585	1440	1760
50	50	10	200	46	63	224	120	38	2449	2195	2753
65	50	10	200	46	75	284	120	44	2579	2285	2931

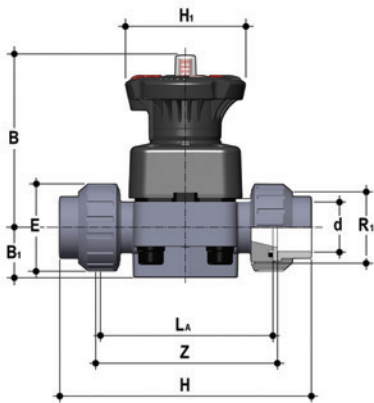

2-way diaphragm valve with **female union ends** for solvent respectively socket welding, **metric series**, code 30

DN	MA	PN	B	B ₁	d	E	H		H ₁	L _A	R ₁	Z		Weight (g)		
							ABS PVC-U PVC-C	PP-H PVDF				ABS PVC-U PVC-C	PP-H PVDF	PVC-U PVC-C	PP-H ABS	PVDF
15	20	10	102	25	20	41	129	128	80	90	1"	100	101	500	457	551
20	20	10	105	30	25	50	154	150	80	108	1" 1/4	116	119	562	500	636
25	25	10	114	33	32	58	168	163	80	116	1" 1/2	124	127	790	695	905
32	25	10	119	30	40	72	192	184	80	134	2"	140	145	916	781	1077
40	40	10	147	35	50	79	222	210	120	154	2" 1/4	160	165	1737	1526	1989
50	50	10	172	46	63	98	266	248	120	184	2" 3/4	190	195	2785	2410	3235

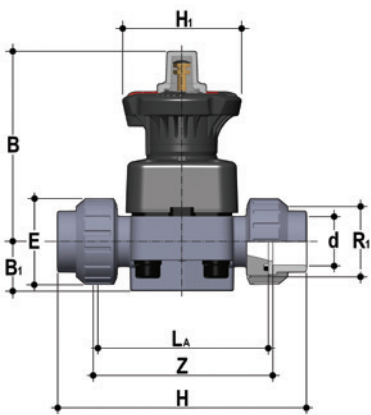

2-way diaphragm valve with **stroke limiter and female union ends** for solvent respectively socket welding, **metric series**, code 30

DN	MA	PN	B	B ₁	d	E	H		H ₁	L _A	R ₁	Z		Weight (g)		
							ABS PVC-U PVC-C	PP-H PVDF				ABS PVC-U PVC-C	PP-H PVDF	PVC-U PVC-C	PP-H ABS	PVDF
15	20	10	115	25	20	41	129	128	80	90	1"	100	101	530	487	581
20	20	10	118	30	25	50	154	150	80	108	1" 1/4	116	119	592	530	666
25	25	10	127	33	32	58	168	163	80	116	1" 1/2	124	127	820	725	935
32	25	10	132	30	40	72	192	184	80	134	2"	140	145	946	811	1107
40	40	10	175	35	50	79	222	210	120	154	2" 1/4	160	165	1797	1586	2049
50	50	10	200	46	63	98	266	248	120	184	2" 3/4	190	195	2845	2470	3295

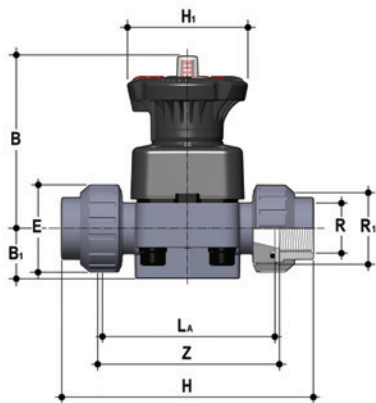

2-way diaphragm valve with **BSP threaded female union ends**, code 33

DN	MA	PN	B	B ₁	E	H	H ₁	L _A	R ₁	Z	Weight (g)	
											PVC-U	PVC-C
15	20	10	102	25	41	131	80	90	1"	97	500	
20	20	10	105	30	50	151	80	108	1" 1/4	118	562	
25	25	10	114	33	58	165	80	116	1" 1/2	127	790	
32	25	10	119	30	72	188	80	134	2"	145	916	
40	40	10	147	35	79	208	120	154	2" 1/4	165	1737	
50	50	10	172	46	98	246	120	184	2" 3/4	195	2785	

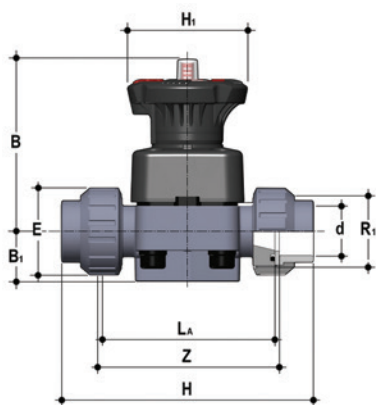

2-way diaphragm valve with **female union ends** for solvent welding, **ASTM series**, code 32

DN	MA	PN	B	B ₁	d	E	H	H ₁	L _A	R ₁	Z	Weight (g)	
												PVC-U	PVC-C
15	20	10	102	25	20	41	143	80	90	1"	98	500	
20	20	10	105	30	25	50	167	80	108	1" 1/4	115	562	
25	25	10	114	33	32	58	180	80	116	1" 1/2	122	790	
32	25	10	119	30	40	72	208	80	134	2	144	916	
40	40	10	147	35	50	79	234	120	154	2" 1/4	164	1737	
50	50	10	172	46	63	98	272	120	184	2" 3/4	195	2785	

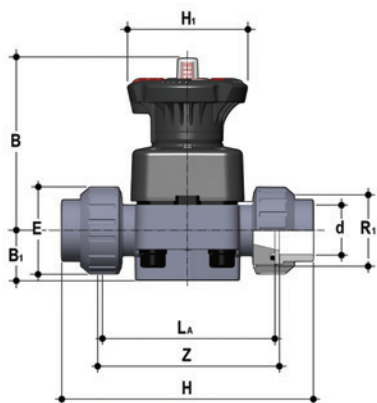

2-way diaphragm valve with **female union ends** for solvent welding, **BS series**, code 31

DN	MA	PN	B	B ₁	E	H	H ₁	L _A	R ₁	Z	Weight (g)	
											PVC-U	PVC-C
15	20	10	102	25	41	131	80	90	1"	97	500	
20	20	10	105	30	50	154	80	108	1" 1/4	116	562	
25	25	10	114	33	58	166	80	116	1" 1/2	121	790	
32	25	10	119	30	72	194	80	134	2"	142	916	
40	40	10	147	35	79	222	120	154	2" 1/4	162	1737	
50	50	10	172	46	98	266	120	184	2" 3/4	194	2785	

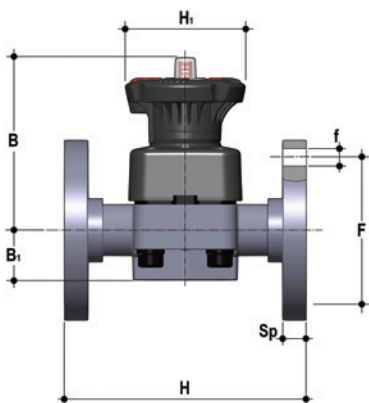

2-way diaphragm valve with **fixed flanges, drilled PN10/16**. Face to face according to EN 558-1, code 81

DN	MA	PN	B	B ₁	f	F	H	H ₁	Sp	U	Weight (g)		
											PVC-U PVC-C	PP-H	PVDF
15	20	10	102	25	14	65	130	80	13.5	4	690	588	810
20	20	10	105	30	14	75	150	80	13.5	4	682	645	862
25	25	10	114	33	14	85	160	80	14	4	972	910	1141
32	25	10	119	30	18	100	180	80	14	4	1186	1110	1532
40	40	10	147	35	18	110	200	120	16	4	2100	1955	2481
50	50	10	172	46	18	125	230	120	16	4	3159	2905	3690
65	50	10	225	55	18	145	290	120	21	4	3619	3325	4263

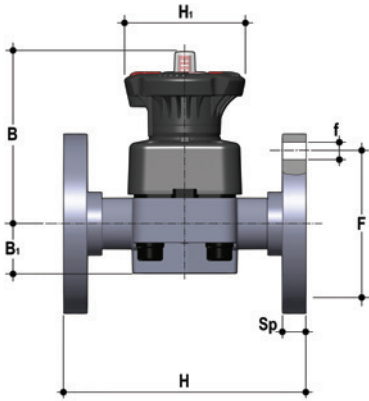

2-way diaphragm valve with **fixed flanges, drilled ANSI B16.5 cl. 150 #FF**, code 88

DN	MA	PN	B	B ₁	f	F	H	H ₁	Sp	U	Weight (g)		
											PVC-U PVC-C	PP-H	PVDF
15	20	10	102	25	14	60.3	108	80	13.5	4	667	572	810
20	20	10	105	30	15.7	69.9	150	80	13.5	4	682	645	862
25	25	10	114	33	15.7	79.4	160	80	14	4	972	910	1141
32	25	10	119	30	15.7	88.9	180	80	14	4	1186	1110	1532
40	40	10	147	35	15.7	98.4	200	120	16	4	2100	1955	2481
50	50	10	172	46	19	120.7	230	120	16	4	3159	2905	3690
65	50	10	172	46	19	139.7	290	120	21	4	3619	3325	4263

ACCESSORIES

Long spigot PE100 end connectors for electrofusion or butt welding, code 36

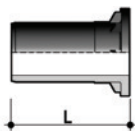

DN	L	H	SDR		
			PVC-U	PVC-C	PP-H
15	95	280	11	11	11
20	95	298	11	11	11
25	95	306	11	11	11
32	95	324	11	11	11
40	95	344	11	11	11
50	95	374	11	11	11

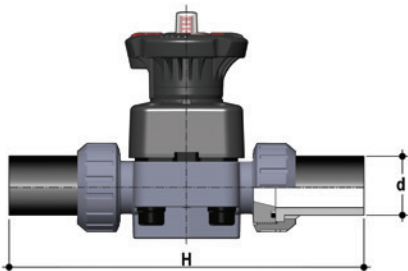

Long spigot PP-H, code 35 and **PVDF** code 30 - S1209 end connectors for butt welding

DN	L	H	SDR	
			PP-H	PVDF
15	95	280	11	21
20	95	298	11	21
25	95	306	11	21
32	95	324	11	21
40	95	344	11	21
50	95	374	11	21

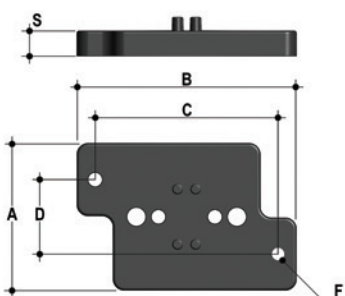

Wall mounting plate PVC-U

DN	A	B	C	D	F	S
15	65	97	81	33	5.5	11
20	65	97	81	33	5.5	11
25	65	97	81	33	5.5	11
32	65	97	81	33	5.5	11
40	65	144	130	33	6.5	11
50	65	144	130	33	6.5	11
65	65	144	130	33	6.5	11

FASTENING AND SUPPORTING



All valves, whether manual or actuated, must be adequately supported in many applications.

The 882 valve series is therefore provided with an integrated bracket that permits direct anchoring of the valve body without the need of other components.

For wall installation, dedicated wall mounting plates which are available as accessories can be used. These plates should be fastened to the valve before wall installation.

The wall plate also allows the 882 valve to be aligned with SED pipe clips.

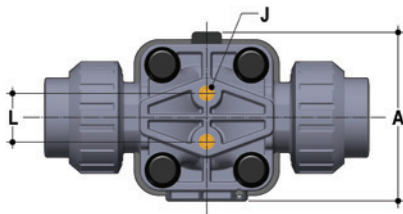

d	DN	A	L	J
20	15	74	25	M6 x 10
25	20	74	25	M6 x 10
32	25	87	25	M6 x 10
40	32	87	25	M6 x 10
50	40	114	44.5	M8 x 14
63	50	136	44.5	M8 x 14
75	65	136	44.5	M8 x 14

CUSTOMIZATION

The 882 DN 15-65 valve can be customised using a customization plate in white PVC.

The customization plate (B), housed in the transparent protection cap (A), can be removed and, once overturned, used for indicating identification serial numbers or service indications on the valves such as, for example, the valve function in the system, the conveyed fluid, but also specific information for customer service, such as the customer name or installation date or location on the valves. The waterproof transparent protection cap with seal O-Ring protect the customization plate against deterioration.

To access the customization plate, make sure that the handwheel is in the release position and proceed as follows:

- 1) Rotate the transparent protection cap fully anticlockwise (fig. 1) and remove it by pulling upwards. If necessary, insert a screwdriver in slot (C) to make the operation easier (fig. 2).
- 2) Remove the plate from inside the transparent protection cap and customise as required (fig. 3).
- 3) Re-assemble everything making sure that the transparent protection cap O-Ring remains in its seating (fig. 4).

Fig. 1



Fig. 2



Fig. 3

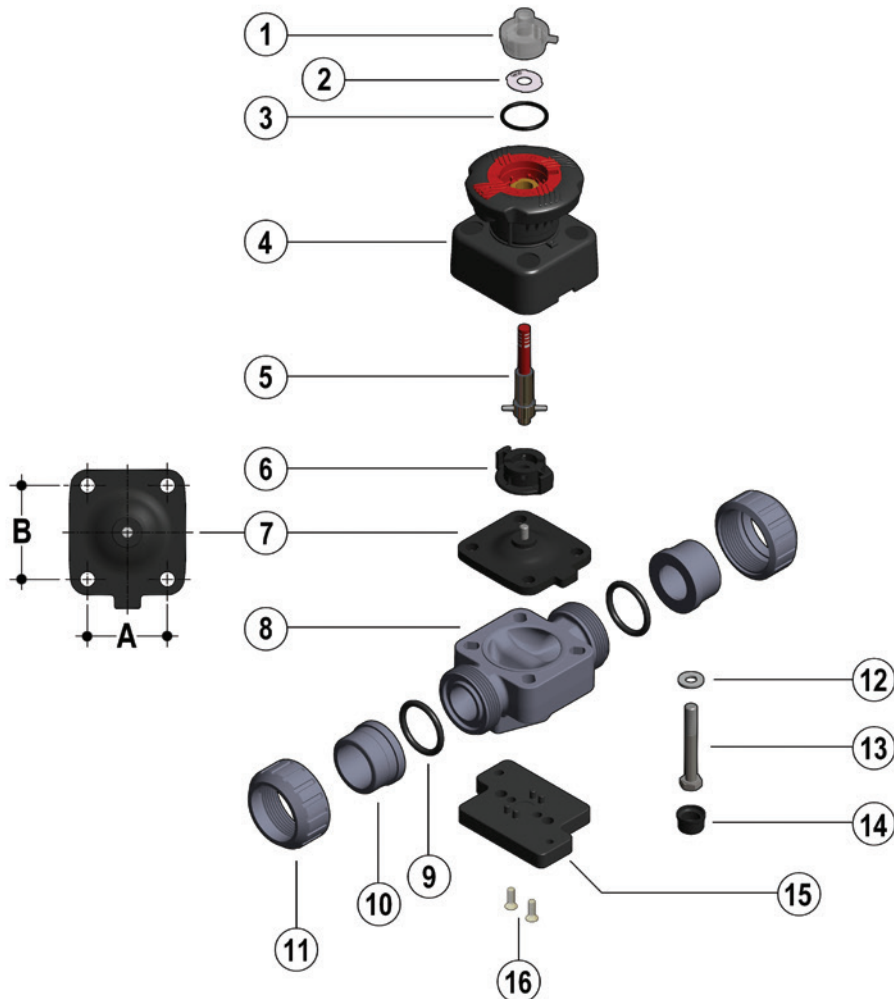

Fig. 4



COMPONENTS

EXPLODED VIEW DN 15-50



DN	15	20	25	32	40	50	65
A	40	40	46	46	65	78	78
B	44	44	54	54	70	82	82

- 1** · Transparent protection cap (PVC - 1)*
- 2** · Customization plate (PVC - 1)
- 3** · O-Ring (EPDM - 1)
- 4** · Operating mechanism (PP-GR / PVDF - 1)
- 5** · Threaded stem - Indicator (Stainless steel - 1)

- 6** · Compressor (IXEF - 1)
- 7** · Diaphragm seal (EPDM, FPM, PTFE - 1)*
- 8** · Valve body (PVC-U - 1)*
- 9** · Socket seal O-ring (EPDM-FPM - 2)*
- 10** · End connector (PVC-U - 2)*
- 11** · Union nut (PVC-U - 2)*

- 12** · Washer (Stainless steel - 4)
- 13** · Bolt (Stainless steel - 4)
- 14** · Protection plug (PE - 4)
- 15** · Distance plate (PP-GR - 1)**
- 16** · Screw (Stainless steel - 2)**

* Spare parts

** Accessories

The material of the component and the quantity supplied are indicated between brackets

DISASSEMBLY

- 1) Isolate the valve from the line (release the pressure and empty the pipeline).
- 2) If necessary, release the handwheel by pressing downwards (fig.5) and rotating anticlockwise to fully open the valve.
- 3) Unscrew the union nuts (11) and extract the valve sideways.
- 4) Remove the protection plugs (14) and bolts (13) with the relative washers (12).
- 5) Separate the valve body (8) from the internal components (4).
- 6) Rotate the handwheel clockwise to free the threaded stem (5), compressor (6) and diaphragm (7)
- 7) Unscrew the diaphragm (7) and remove the shutter (6).

ASSEMBLY

- 1) Insert the compressor (6) on the threaded stem (5) aligning it correctly with the reference pin on the stem.
- 2) Screw the diaphragm (7) on the threaded stem (5).
- 3) Lubricate the threaded stem (5), insert it in the operating mechanism (4) and rotate the handwheel anticlockwise until the stem is fully screwed in (5). Make sure that the compressor (6) and diaphragm are correctly aligned with the housings in the operating mechanism (4) (fig. 7).
- 4) Fit the operating mechanism (4) on the valve body (8) and tighten the bolts (13) with the relative washers (12).
- 5) Tighten the bolts (13) evenly (diagonally) to the tightening torque suggested on the relative instruction sheet.
- 6) Replace the protection plugs (14)
- 7) Position the valve body between the end connectors (10) and tighten the union nuts (11), making sure that the socket seal O-rings (9) do not exit their seats.
- 8) If necessary, block the handwheel by grasping it and pulling it upwards (fig. 6).

Note: during assembly, it is advisable to lubricate the threaded stem. Mineral oils are not recommended for this task as they react aggressively with EPDM rubber.

Fig. 5



Fig. 6



Fig. 7

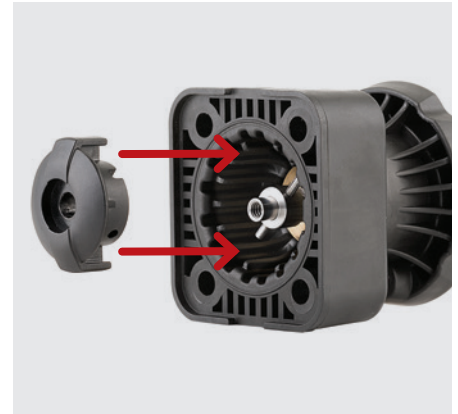

INSTALLATION

Before proceeding with installation, please follow these instructions carefully: (these instructions refer to union end versions). The valve can be installed in any position and in any direction.

- 1) Check that the pipes to be connected to the valve are aligned in order to avoid mechanical stress on the threaded joints.
- 2) Unscrew the union nuts (11) and insert them on the pipe segments.
- 3) Solvent weld or screw the end connectors (10) onto the pipe ends.
- 4) Position the valve body between the end connectors, making sure that the socket seal O-rings (9) do not exit their seats.
- 5) Fully tighten the union nuts (11).
- 6) If necessary, support the pipework with SED pipe clips or by means of the carrier built into the valve itself (see paragraph "Fastening and supporting").

 **Note:** Before putting the valve into service, check that the bolts on the valve body (13) are tightened correctly at the suggested torque.

Fig. 9



ADJUSTMENT

LOCKING DEVICE



The 882 valve is equipped with a handwheel locking system that prevents the valve from being operated. The system can be engaged by simply lifting the handwheel once the required position has been reached (fig. 8). To release the operating mechanism, simply return the handwheel to its previous position by pushing it downwards (fig. 6). When the system is in the locked position, a lock can be installed to protect the plant against unwanted interference (fig. 9).

STROKE LIMITER

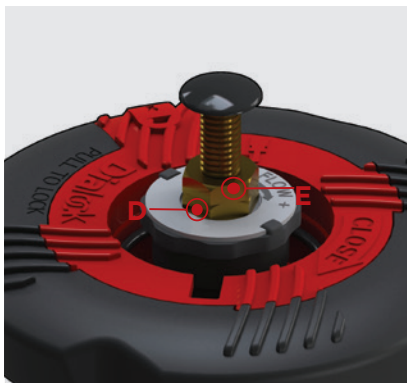

The version of the diaphragm valve equipped with a handwheel stroke control system allows the minimum and maximum flows to be preset. The system allows the valve stroke to be modified using the two independent adjusting screws, which determine the mechanical limits of the valve during opening and closing. The valve is sold with the stroke limiters positioned such that does not limit the opening or closing stroke. To access and set the adjusting screws, remove the transparent protection cap (A) as previously described (see chapter "Customization").

Travel stop adjustment. Minimum flow rate

- 1) Rotate the handwheel clockwise until the required minimum flow rate is reached.
- 2) Screw in nut (D) as far as it will go and lock it in this position by tightening the lock-nut (E).
If it is not necessary to limit the closing stroke, completely unscrew nuts (D and E). In this way, the valve will fully close.
- 3) Re-assemble the transparent protection cap making sure that the seal O-Ring remains in its seating.

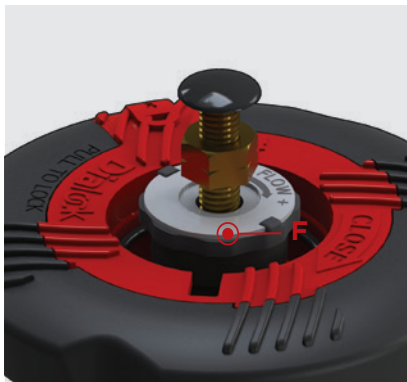

Stroke limiter adjustment. Maximum flow rate

- 1) Rotate the handwheel anticlockwise until the required maximum flow rate is reached.
- 2) Rotate knob (F) anticlockwise as far as the stop. The plate indicates the direction of rotation of the wheel required to obtain a higher or lower maximum flow rate. If the opening stroke does not need to be limited, rotate the knob (F) clockwise a number of times. In this way, the valve will fully open.
- 3) Re-assemble the transparent protection cap making sure that the seal O-Ring remains in its seating.

TYPE 885

DN 80-100

The 885 is particularly suitable for shutting off and regulating abrasive or dirty fluids. The handwheel control and diaphragm seal provide precise and effective control, while reducing the risk of water hammer to a minimum.

2-WAY DIAPHRAGM VALVE

- Connection system for solvent weld, threaded and flanged joints
- Compact and lightweight construction
- High flow coefficient and minimum pressure drop
- **Internal components in metal, totally isolated from the conveyed fluid**, with anti-friction disk to reduce friction to a minimum
- **Modularity of the range:** only 2 handwheel and 2 diaphragm and bonnet sizes for 2 different valve sizes
- Handwheel that stays at the same height during rotation
- Bonnet fastening screws that crew into the built-in bush preventing the deposit of dirt or impurities
- **CDSA** (Circular Diaphragm Sealing Angle) system that, thanks to the uniform distribution of shutter pressure on the diaphragm seal, offers the following advantages:
 - reduction in the tightening torque of the screws fixing the actuator to the valve body
 - reduced mechanical stress on all valve components (actuator, body and diaphragm)
 - easy to clean valve interior
 - low risk of the accumulation of deposits, contamination or damage to the diaphragm due to crystallisation
 - operating torque reduction

Technical specifications	
Construction	2-way diaphragm valve
Size range	DN 80 - 100
Diaphragm size	MA 80 - 100
Nominal pressure	PN 10 with water at 20° C
Temperature range	PVC-U: 0 °C - 60 °C - PVC-C: 0 °C - 100 °C PP-H: 0 °C - 100 °C - PVDF: -20 °C - 120 °C ABS: -20 °C - 80 °C
Coupling standards	Solvent welding / Welding: EN ISO 1452, EN ISO 15493, BS 4346-1, DIN 8063, NF T54-028, ASTM D 2467. Can be coupled to pipes according to EN ISO 1452, EN ISO 15493, DIN 8062, NF T54-016, ASTM D 1785
	Flanging system: ISO 7005-1, EN ISO 1452, EN ISO 15493, EN 558-1, DIN 2501, ANSI B16.5 Cl.150, JIS B22200
Reference standards	Construction criteria: EN ISO 16138, EN ISO 1452, EN ISO 15493 Test methods and requirements: ISO 9393 Installation criteria: DVS 2204, DVS 2221, UNI 11242
Valve material	Body: PVC-U / PVC-C / PP-H / PVDF / ABS Bonnet: PP-GR Position indicator cap: PVC
Diaphragm material	EPDM, FPM, PTFE (on request NBR)
Control options	Manual control; pneumatic actuator

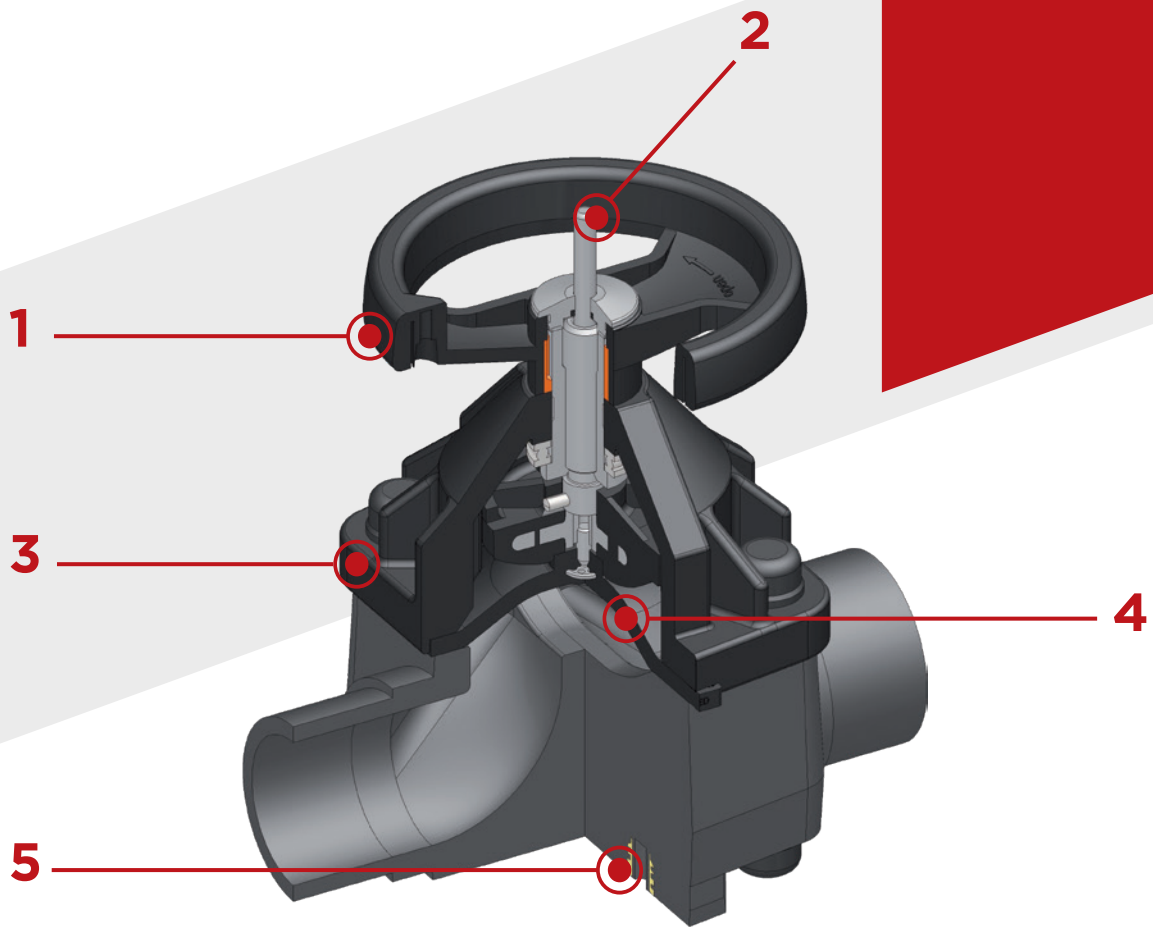

1 Handwheel in (PP-GR) with high mechanical strength and **ergonomic grip for optimum manageability**

2 Optical position indicator supplied as standard

3 Full protection bonnet in PP-GR, no protruding bolts , no areas where impurities can accumulate.
Internal circular and symmetrical diaphragm sealing area

4 Diaphragm available in EPDM, FPM, PTFE (NBR on request) and easy to replace

5 Threaded metal inserts for anchoring the valve

TECHNICAL DATA

PRESSURE VARIATION ACCORDING TO TEMPERATURE

For water and harmless fluids to which the material is classified as CHEMICALLY RESISTANT. In other cases, a reduction of the nominal pressure PN is required (25 years with safety factor).

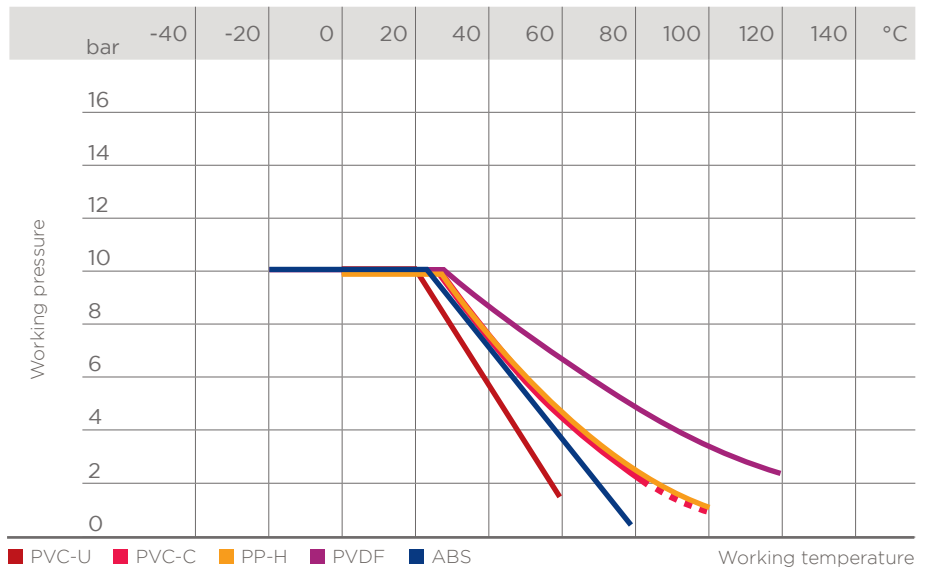

PRESSURE DROP GRAPH

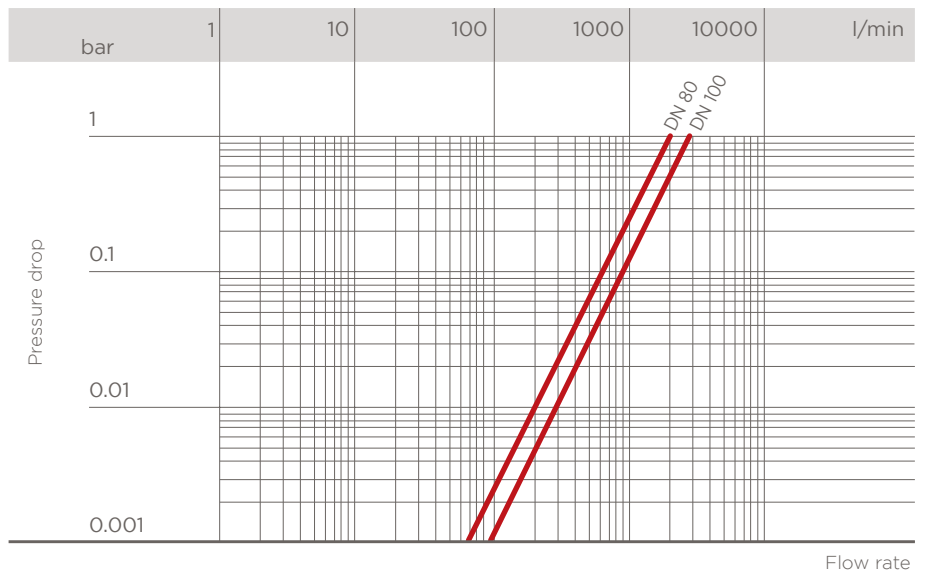

K_v100 FLOW COEFFICIENT

The K_v100 flow coefficient is the Q flow of litres per minute of water at a temperature of 20°C that will generate Δp= 1 bar pressure drop at a certain valve position.

The K_v100 values shown in the table are calculated with the valve completely open.

DN	80	100
K _v 100 l/min	2000	2700

DIMENSIONS - TYPE 885

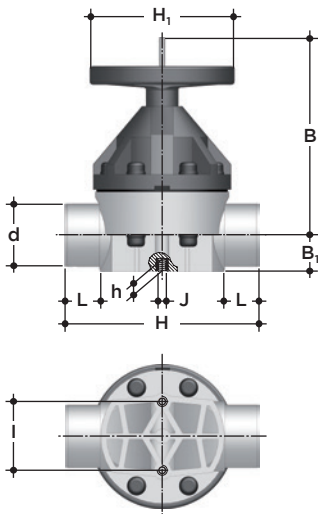

2-way diaphragm valve with **male ends** for solvent respectively socket welding, **metric series**, code 39

DN	MA	PN	B	B ₁	d	H	h	H ₁	I	J	L	Weight (g)			
												PVC-U PVC-C	PP-H	PVDF	ABS
80	80	10*	225	55	90	300	23	200	100	M12	51	7000	6100	7700	6000
100	100	10*	295	69	110	340	23	250	120	M12	61	10500	8500	12700	9000

* PTFE PN6

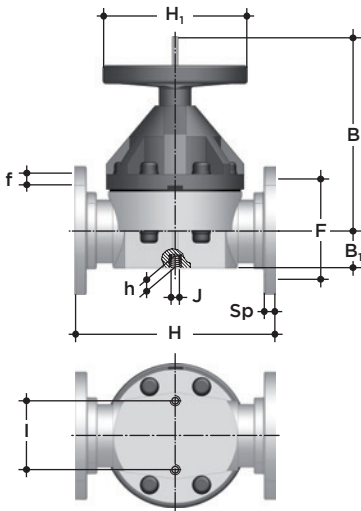

2-way diaphragm valve with **fixed flanges, drilled PN10/16**. Face to face according to EN 558-1, code 81

DN	MA	PN	B	B ₁	F	f	H	H ₁	I	J	Sp	U	Weight (g)		
													PVC-U PVC-C	PP-H	PVDF
80	80	10*	225	55	160	18	310	200	100	M12	21.5	8	8500	7600	9200
100	100	10*	295	69	180	18	350	250	120	M12	22.5	8	12400	10400	14600

* PTFE PN6

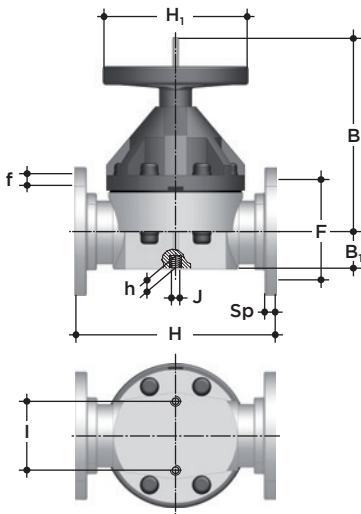

2-way diaphragm valve with **fixed flanges, drilled ANSI B16.5 cl. 150 #FF**, Face to face according to EN 558-1, code 88

DN	MA	PN	B	B ₁	F	f	H	H ₁	I	J	Sp	U	Weight (g)		
													PVC-U PVC-C	PP-H	PVDF
80	80	10*	225	55	152.4	19.1	310	200	100	M12	21.5	4	8500	7600	9200
100	100	10*	295	69	190.5	19.1	350	250	120	M12	22.5	8	12400	10400	14600

* PTFE PN6

COMPONENTS

EXPLODED VIEW DN 80

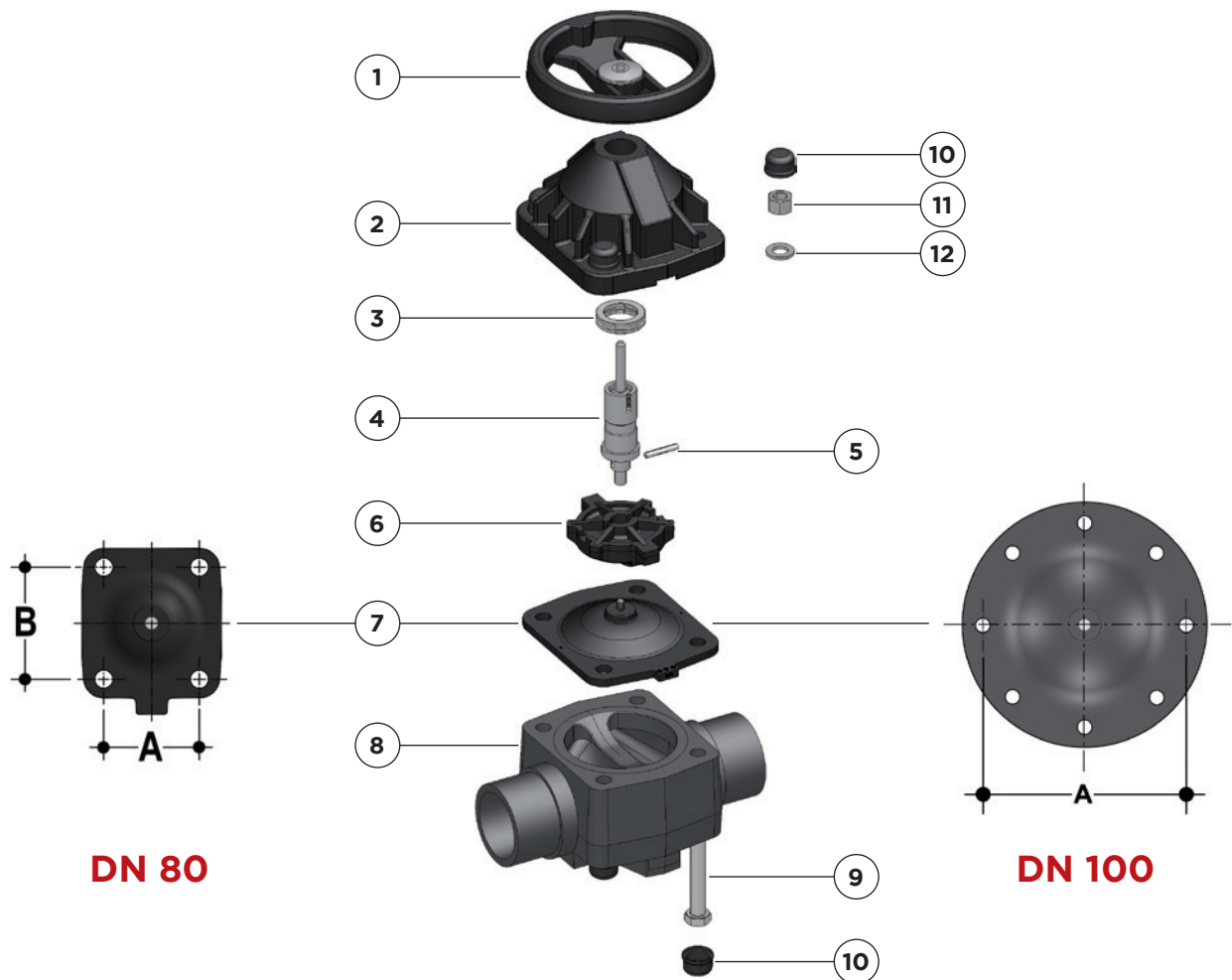

DN	80	100
A	114	193
B	127	-

- 1** · Handwheel (PP-GR - 1)
- 2** · Bonnet (PP-GR - 1)
- 3** · Ball bearing (.... - 1)
- 4** · Indicator - stem (STAINLESS steel - 1)
- 5** · Pin (STAINLESS steel)
- 6** · Compressor (DN 80 PBT)
- 7** · Diaphragm (EPDM, FPM, PTFE - 1)
- 8** · Body (PVC-U / PVC-C / PP-H / PVDF / ABS)
- 9** · Hexagonal screw (Zinc plated steel - 4)
- 10** · Protection plug (PE - 4)
- 11** · Nut (STAINLESS steel - 4)
- 12** · Washer (Zinc plated steel - 4)

The material of the component and the quantity supplied are indicated between brackets

DISMOUNTING

If the valve is already installed on the line, shut-off the fluid flow upstream and make sure that there is no pressure. If necessary, fully drain the system downstream. If there are hazardous fluids present, drain and ventilate the valve.

The diaphragm constitutes the part of the valve more subject to mechanical and chemical stress from the fluid. Consequently, the condition of the diaphragm must be checked at regular intervals in accordance with the service conditions. To do this, it must be disconnected from the handwheel and from the valve body

- 1) Unscrew the four screws (9) and separate the body (8) from the internal components.
- 2) Unscrew the diaphragm (7) from the shutter (6). Rotate the handwheel clockwise to free the stem-shutter unit.
- 3) If necessary, clean or replace the diaphragm (7).
- 4) If necessary, lubricate the stem (4).

MOUNTING

- 1) Insert the handwheel in the bonnet (2)
- 2) The ball bearing (3) must be positioned on the sleeve over the bonnet. To ensure a perfect seal, use a liquid sealing compound such as Loctite.
- 3) Subsequently, the shutter (6) must be removed from the stem (4) and fixed using the pin. Warning: the pin must be well secured in the seating hole in the stem.
- 4) The stem (4) must now be screwed to the threaded sleeve. Warning: lefthand thread. The shutter (6) must be oriented such that the guide pins correspond with the grooves in the bonnet.
- 5) The shutter (6) must be fully tightened on the bonnet by rotating the handwheel. Then, the diaphragm (7) must be screwed fully into the bonnet and then rotated in the opposite direction until the holes in the diaphragm coincides with the holes in the bonnet.
- 6) Place the bonnet with the diaphragm in the correct position in the body (8). Fix the protection plugs (10) using the hexagonal screws and washers (12). Tighten evenly (cross-like).

INSTALLATION

The valve can be installed in any position and in any direction.

When starting up the plant, make sure that there are no leaks from between the diaphragm and the valve body. If necessary, tighten the fastening screws (9).

ORDERING KEY

1	2	3	4	5	6.1	6.2
Type	Size	Valve body material	Valve body end connection	Diaphragm material	Actuator control function	Actuator type

Pos.	Description	Code	Specification
1	Type:	286	Plastic actuator, manual, MA10
		882	Plastic actuator, manual, MA20-50
		885	Plastic actuator, manual, MA80-100
2	Size:	12 - 100	DN 12, 15, 20, 25, 32, 40, 50, 65, 80, 100
3	Valve body material:	1	PVC-U
		2	PP-H
		3	PVDF
		4	PVC-C
		5	ABS
4	Valve body end connections:	1	Threaded socket DIN ISO 228
		2	Cementing spigots DIN
		30	Female union ends for solvent / socket welding, metric series
		31	Female union ends for solvent / socket welding, BS series
		32	Female union ends for solvent / socket welding, ASTM series
		33	Union with BSP threaded female union ends
		35	Union with long spigot PP-H end connectors for butt welding
		36	Union with long spigot PE100 end connectors for electrofusion or butt welding
		39	Male ends for solvent / socket welding, metric series
		81	Fixed flanges, drilled PN10/16. Face to face according to EN 558-188
5	Diaphragm material:	1	EPDM
		2	FPM (Viton)
		4	NBR (Perbunan)
		29	PTFE(TFM) / EPDM one-piece, DN 15 (MA20) - DN 65 (MA50)
		44	PTFE(TFM) / EPDM two-piece, DN 25 (MA25) - DN 100 (MA100)
6.1	Actuator control function:	-	Manually operated
6.2	Actuator type:	S	Plastic actuator max. 80°C, DN 12 - 15 (MA10) / DN 80 + 100 (MA80 + 100)
		SF	Plastic actuator max. 80°C, DN 15 (MA20) - DN 65 (MA50)
7	S-Number:	S...	To specify customized design

Visit our website and check out our product selection program (Configurator) to specify the right product for your application. Actuated valves see separate leaflet TD16 0115 Rev.a

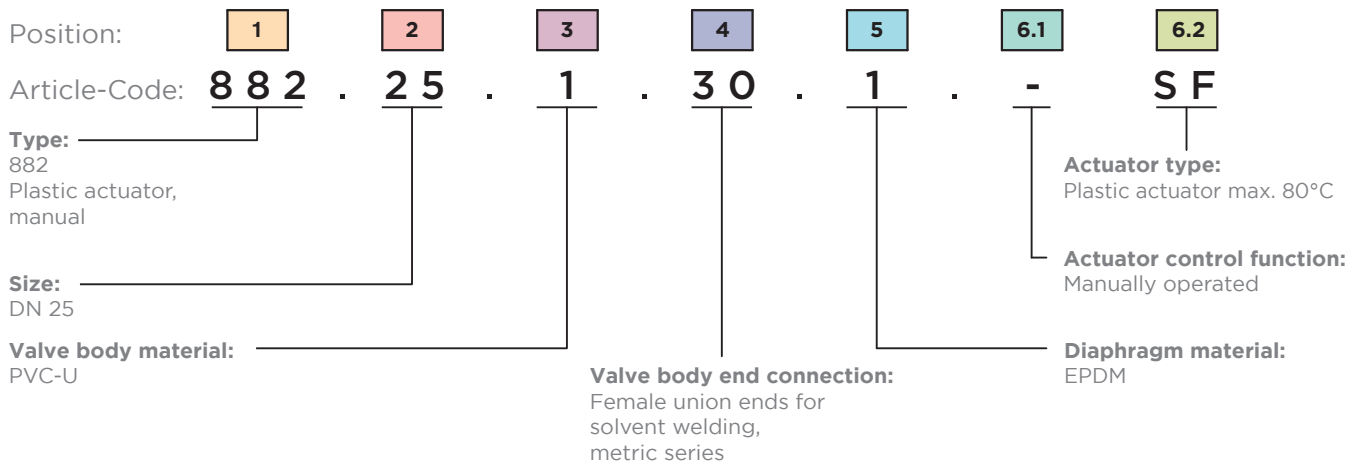

OVERVIEW PRODUCT RANGE

DIAPHRAGM VALVE



Aseptic Diaphragm Valve



Industrial Metal Diaphragm Valve



Plastic Diaphragm Valve

ANGLE SEAT VALVE



Two-Way Metal Angle Seat Valve

ASEPTIC PROCESS SOLUTION



Sterile sampling unit

SYSTEM COMPONENTS



Contact - Free Limit Switch



Control Head



Digital Electropneumatic Positioner

FLOW MEASUREMENT



Variable Area Flowmeter



Measuring Sensor

SAMSON

SAMSON SED

CATALOG



Manual
Diaphragm
Valve

SED Flow Control GmbH
Am Schafbaum 2 · 74906 Bad Rappenau
Telefon: +49 7264 921 0 · Telefax: +49 7264 921 21
E-Mail: info@sed-flowcontrol.com · Internet: www.sed-flowcontrol.com

TD16.011.4 Rev.b, Subject to alteration

SMART IN FLOW CONTROL.

控制阀大全 - 三千控制阀网

www.CV3000.com