

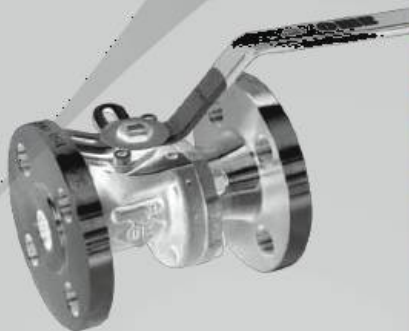

三千控制阀网 www

.com



**OMIB**<sup>®</sup>  
VALVES s.p.a.



**C-GEN5**



**Company Profile**

# OMB Valves Group



The OMB Valves group, headquartered in Cenate Sotto, Bergamo, Italy, is a diversified manufacturer of valves for the energy industries.

Founded by Mr. Roberto Brevi in 1973, OMB is a family owned and operated group which has become a globally recognised manufacturer of forged steel valves with manufacturing operations in Europe, Asia and Middle East supported by a worldwide distribution network.

## Our mission

To provide the highest possible quality forged steel valves at the most cost effective way to customers worldwide in the energy related industries.

三千控制阀



# Offshore

三千控制阀网 [www.cv3000.com](http://www.cv3000.com)



## TCGV

### OIL AND GAS PRODUCTION

OMB Valves supplies a complete range of integral flanged ends valves and specialty products which are mainly used in the offshore and on-shore oil and gas production sites. With more than 25 year experience in supplying valves for the demanding fields of the North Sea, the Middle East,

South East Asia and the Persian Gulf, OMB offers a complete range of solutions for the most severe applications. OMB is qualified to API6D and API 6A: these exacting standards are also applied in the production of thru conduit gate, globe and check valves in classes up to 20000 and any exotic material.

## Sub Sea

Subsea applications valves for the severe service and environmental conditions of the North Sea. Valves are available either manual or equipped for ROV operation.



# Top Entry

三千控制阀网 [www.cv3000.com](http://www.cv3000.com)



1" to 36" forged: this is our experience in the forged top entry ball valves production. We did massive 30 ton valves in full forged blocks for a major end user for a Nigeria offshore development, and a wide range of product were installed offshore Malaysia in the past 5 years.

Cast and forged construction are available for top entry valves: we have basically no size limitation for forged construction having already developed and supplied valves up to 36" in one piece forging.



# Trunnion

三千控制阀网 [www.cv3000.com](http://www.cv3000.com)



## Manual

Our trunnion ball valves range are approved by the major end-users in the world, from Saudi Arabia to Nigeria, Malaysia to Australia. Our Ball valves division's team has developed in the past 20 years a sizeable expertise both in large size valves and high pressure applications.

We expanded our main plant in Cenate Sotto has been expanded to 10,000 sqm in 2005/06 and again in 2011/12 to 15,000 sqm: now it includes all necessary equipment for the manufacturing, assembly and

## Actuated

testing of valves up to 60". With some of the most famous actuators manufacturers a short drive away, we have been able to supply valves to the most stringent requirement for oil and gas field applications worldwide as our reference list can attest.



# Floater

三千控制阀网 [www.cv3000.com](http://www.cv3000.com)



OMB manufactures floating ball valves if forged steel since 1982.

We make valves with **fixed and energized seat** design with soft thermoplastics seat or metal seat with Tungsten, Chrome or Silicium Carbides coatings.

**LIP** type valves have 1 piece design, fire safe certified, available in class 800, 1500 and 2500.

**COMPACT** type valve 3 pieces closed dye forging design, fire safe certified with integral ISO mounting pad.

**FLANGED** valves in 2 pieces are manufactured from closed dye forgings in strict compliance to ASTM requirement, in class 150 to 2500.

**TOPENTRY** valves have 1 piece forged body either butt welded or integral flanges, designed with energized seats in class 150 to 2500.

We have a vast range of elastomers and thermoplastics seal options to meet the most severe applications.

All our valves have passed the latest Fugitive Emission tests requirements.



# Modular

三千控制阀网 [www.cv3000.com](http://www.cv3000.com)



## DBB

OMB dual expertise in gate/globe and check valves and in ball valves comes together in the development of modular double block and bleed valves. Combining forged components of globe valves for the usual needle bleed valve and the various options of the ball valve modules we offer valves size 1/4" to 12" in all pressure classes and materials.

During the past 5 years we have supplied a growing number of customers: from North Sea end-users looking to substitute single valve to modular valves with the same body length to Agip KCO in Kazakhstan Kashagan development field where special environmental and application requirements led to the use of high alloys with metal seated balls.



# Cryogenic

三千控制阀网 [www.cv3000.com](http://www.cv3000.com)



We have supplied some of the largest LNG plants in the world from Malaysia to Qatar and Nigeria. We have a vast experience in the requirements of LNG receiving terminals and storage tanks and in the specialized shipbuilding industry.

Our solutions for the low temperature field cover both the forged steel gate, globe and check valves and the ball valves range. Here we manufacture valves from 1/2" to 24" in floating and trunnion mounted designs and we have developed a complete set of testing pools able to handle valves up to 24" class 900.

## Testing facilities

Cryogenic testing is carried out on site where valves are submerged in liquid nitrogen at -196C and leak tested with helium gas.

We have specially built multiple test equipments to handle large batches of forged steel and small size ball valves. Other test facilities include five hydraulic & hydrostatic test rigs, the largest of which can test valves up to 24".

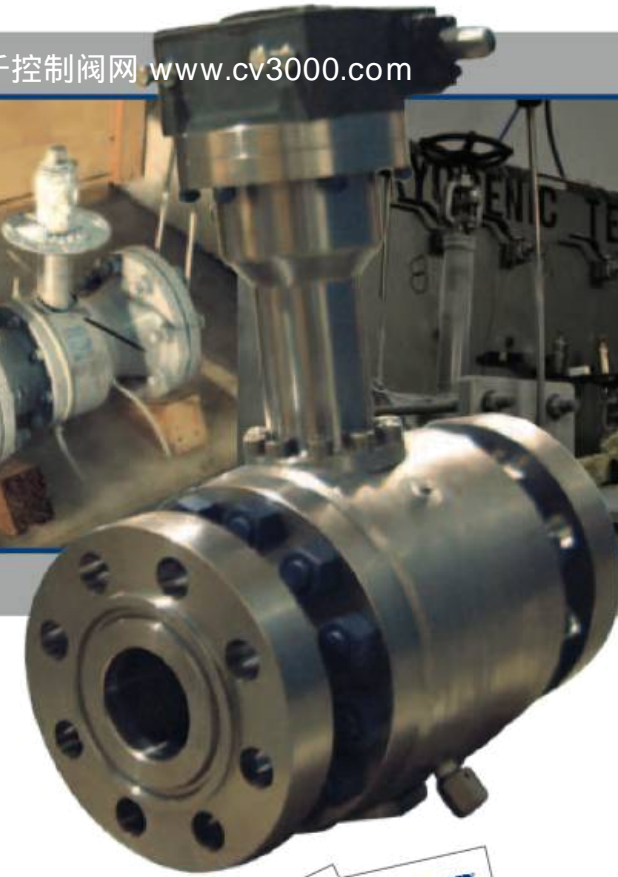



# Process Plant

三千控制阀网 [www.cv3000.com](http://www.cv3000.com)



## OMB Forged Steel Valves

OMB division manufactures gate, globe and check valves for the hydrocarbons and chemical processing plants. The experience in supplying engineering companies at the construction phase makes OMB a reliable source of expertise in the choice, design, installation and maintenance of valves where a complete guarantee of superior operation and long reliability is required.



**Design** Basic design options such as bolted bonnet, welded bonnet in both threaded and seal welded and full penetration weld, socket welding end or flanged and so forth, are available as well as specialty made pieces such as angle, self closing, and stop check design, etc.

Valves are manufactured to ISO15761/API 602 8th edition in pressure class 150 to 4500. The latest standards are followed in every area of the manufacturing, testing and NDE examination.

**Materials** Forgings are sourced only in Italy and are available in more than 50 ASTM denominated materials: from A105 to Titanium including all the alloys and stainless steels. OMB has a very large inventory of parts including the most exotic steel.

**Options** OMB has in the past 30 years exponentially increased the number of options offered to meet specialized customer requirement for unique services. A complete set of information is available in the Catalogue C-18.





## Exotics

Alloy625, Alloy825, Titanium, Super Austenitic F44, 904L, 926, Duplex and SuperDuplex alloys: OMB has a sizable inventory of raw materials and parts and can manufacture quickly any type of valves from forged bars and blocks.



# Bellows

三千控制阀网 [www.cv3000.com](http://www.cv3000.com)



## Eco-L-Valves®

Roberto Brevi, OMB founder, invented in the early nineties the Eco-L-Valves to meet the nascent demand of fugitive emission control combined with small size, competitive pricing and high volume production.

Today hundreds of thousands valves are installed in the world witnessing the success of this unique product: it combines the API 602 valve dimensions with a compact interchangeable bellows thus allowing scheduled preventive maintenance.

With its standard production, OMB has been able to meet the severe requirements of the industries which it serve.

Gearing its engineering and manufacturing departments to meet the fast response demands of the oil and gas, power and general industries, OMB has proven its capacity on supplying special design valves.



# Power

三千控制阀网 [www.cv3000.com](http://www.cv3000.com)



OMB Forged Steel Valves division offers superior product and service to the power industry, the steam raising plants and the applications of valves in all the other industries: fine chemicals, pharmaceuticals and food processing, air and

special gas production, resins and plastic, pulp and paper. With industry specific products as well as customized designs OMB offers a solution for any problem related to the control and safety of operation involving any type of air, gas, steam, vapours and liquid.

Y-pattern welded bonnet and pressure seal bonnet valves are available in carbon, low alloys such as F91 and high temperature stainless and specialty steel for the steam generating operation of power plants.



# Certificates

三千控制阀网 [www.cv3000.com](http://www.cv3000.com)



# Policy Statement



## OMB KEY PRINCIPLES RELATING TO ENVIRONMENT, HEALTH AND SAFETY POLICY

OMB considers it is strategically important for the satisfaction of its customers, employees, visitors, suppliers and the community in which it operates, to achieve standards of excellence in the field of health, safety at work and environmental protection.

It is a priority in corporate management to protect and promote respect for the environment and health and safety at work of all employees in order to ensure long-term sustainability of the business.

All OMB employees, in accordance with their skills and their role, are compelled to integrate this policy in their business processes, to adopt the key principles listed below and to be actively involved in the growth of the management system with comments and suggestions for improvement.

### KEY PRINCIPLES:

- To ensure full compliance with current legislation, standards of good practice, through specific company standards, constantly evaluating the correct and proper implementation of the laws, regulations and contractual obligations.
- To maintain a healthy work environment in the use of products, equipment and methods of work with low risk, motivating and encouraging all employees to achieve the goal of zero accidents, occupational diseases and injuries.

- Analyze potential hazards, of dangerous situations, missed incidents or incidents, injuries in order to identify the root causes and to prevent the recurrence.
- To evaluate any possible negative environmental impacts related to its business, its products and its services, such as reduction of waste and emissions, including CO<sub>2</sub>, rationalizing the use of non-renewable resources, by focusing on feasible, short and medium term objectives.



- To increase awareness, to inform and train the management and all the employees in order to improve the wealth of knowledge and expertise that applies to social objectives and core business in terms of safety, health and environmental protection.
- To promote cooperation and coordination with customers, suppliers and contractors communicating and exchanging the knowledge of procedures and requirements for health, safety

and environment.

- To periodically check the operating and forecasting practices in order to assess compliance with the policy of environmental protection, health and safety at work.
- Interact with associations, authorities and general public institutions, in compliance with the principle of transparency.
- To spread the knowledge of environmental and health and safety policy, business strategy and the results achieved, inside and outside the company, involving public authorities, customers and the public.

OMB environment, health and safety policy, based on these key principles, is sized according to the nature and volume of the activities, to the impacts on the environment and on health and safety aspects.

The policy includes the commitment to continuous improvement and compliance with current legislation.

It also provides the framework for setting and reviewing environmental objectives and environment, health and safety goals defined by OMB.

It will be necessary to initiate a procedure for the identification of environmental aspects and risks, which will be reflected in the initial environmental analysis, in the assessment of risks to the safety and health at work.

# OMB Group Fact Sheet

三千控制阀网 [www.cv3000.com](http://www.cv3000.com)



Automated body machining



Integral flange machining

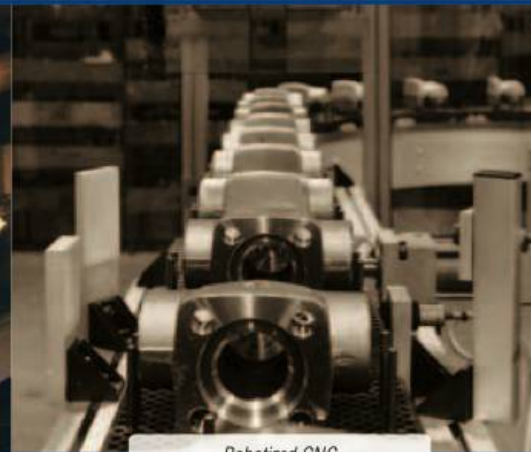

Robotized CNC

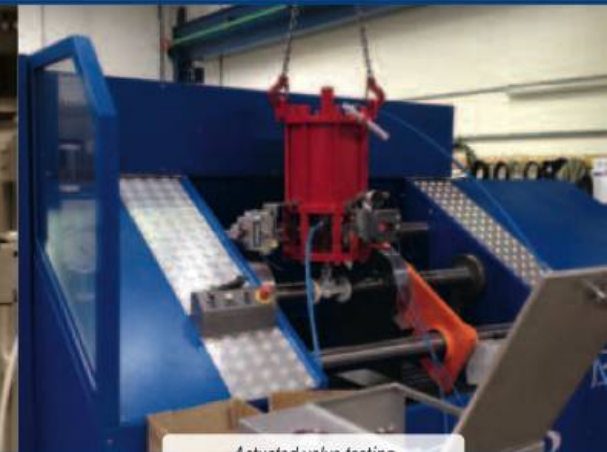

Actuated valve testing

## Headquarters

OMB Valves s.p.a.  
Via Europa, 7  
24069 Cenate Sotto (Bergamo)  
ph 39-0354256711  
fax 39-035942638

## Company legal status

(s.p.a. - stock company) with capital of 2.000.000 Euro. Incorporated in 1973, registered in Bergamo. Controlled by Eli.Fin s.p.a. Eli.Fin s.p.a. is the Brevi family holding company active in various field mainly related to the manufacturing and real estate developments.

## Group members

MANUFACTURING CENTER

- **OMB Valves s.p.a.**  
Cenate Sotto, BG- ITALY
- **OMB Americas Inc.**  
Stafford, TX - USA
- **OMB Valves Asia Pte. Ltd.**  
Woodlands - SINGAPORE
- **Fluicon Valves srl**  
Cenate Sotto, BG - ITALY
- **Calobri srl**  
Settimo Milanese, MI - ITALY
- **IVM-OMB Saudi**  
Al Khobar - SAUDI ARABIA

## REPRESENTATIVE OFFICE

- **OMB Offshore Application Ltd.**  
Dundee, SCOTLAND - UK
- **OMB Americas**  
Montréal - CANADA  
*Sales office*
- **OMB Valves S.E.Asia**  
Kuala Lumpur - MALAYSIA  
*Sales office*
- **OMB Valves**  
Tokyo - JAPAN  
*Sales office*
- **OMB Valves**  
Seoul - Korea  
*Sales office*
- **OMB Valves**  
Beijing - CHINA  
*Sales office*

## Mission

To provide the highest possible quality forged steel valves at the most cost effective way to customers worldwide in the energy related industries.

## Market

The OMB Group design, manufacture and distribute forged steel gate, globe check and ball valves of various classes, dimensions, materials and in accordance of many international and national industry standards mainly for oil & gas, chemical, and power generation industry.

## Company rank

OMB is among the top three API 602 manufacturers worldwide in terms of volume and market penetration: it has one of the industry most complete approval records from oil & gas and chemical companies worldwide. OMB Ball Valves division, manufacturing complete range of floating and trunnion mounted ball valves from 1/2" to 60", is specialized in project supply.



# OMB Group Fact Sheet

三千控制阀网 [www.cv3000.com](http://www.cv3000.com)



Large OD test area



Gas test bunkers



## A unique approach

OMB unique approach to the market is based on its manufacturing technologies, which allows the company to offer competitive prices for both commodity items and special ones.

## Customers

OMB customer base is composed of the largest energy, oil and chemical companies, such as ExxonMobil, Shell Royal Dutch and Saudi Aramco, Dow, Dupont and SABIC, Petronas, PTT, Pertamina, Chevron, BP, world leading engineering and construction firms such as Bechtel, Chiyoda, Foster Wheeler, Fluor, Hyundai E&C, Tecnicas Reunidas, Kellogg, Snamprogetti, Technip, Toyo Engineering, Petrovietnam, JGC, Daewoo, Daelim, Sime Darby, Nippon Steel.

## Product pricing

OMB is extremely competitive in its offer of commodity (i.e. API602 #800 gate valves) and specialty (i.e. cryogenic service F316/L #300 flanged end gate valves) products. OMB offers as well a complete solution for any special material valve need with a stable "cost based" pricing policy that has no match in the market. With a unique range covering all forged steel valves major cost saving can be achieved in the management of project purchase requisition form a single qualified source such as OMB.

## Customer service

OMB is the only forged steel valves manufacturer with own bases in 3 continents (North America, Europe and Asia) guaranteeing the same level of quality and pricing; OMB offers a complete supply solution tailored for international EPC companies involved in major projects with the ability to manufacture every forged steel valves required and manage internally all tests and inspections; OMB and its distribution network is leader in managing local and global MRO contracts from its 70 local bases.





# Main Product Lines

## OMB - Ball Valves

三千控制阀网 [www.cv3000.com](http://www.cv3000.com)

	Lip 1 piece			Compact - Floating 2 pieces 3 pieces							BSE - Trunion Side Entry				BTE - Trunion Top Entry*				BTE - Trunion Fully Welded					DBB Modular				
	SW - NPT			SW - NPT		FLANGED					FLANGED				FLANGED-BW				FLANGED-BW					FLANGED				
	#800	#1500	#2500	#800	#1500	#150	#300	#600	#1500	#2500	#150 / #600	#900	#1500	#2500	#150 / #600	#900	#1500	#2500	#150	#300	#600	#900	#1500	#2500	#150-600	#900-1500	#2500	
1/2																												
3/4																												
1																												
1 1/2																												
2																												
3																												
4																												
6																												
8																												
10																												
12																												
14																												
16																												
18																												
20																												
24																												
26-30																												
30-38																												
40-60																												

All valves are available Soft and Metal seated

\*Also available cast





# Main Product Lines

## OMB - API6A Valves

三千控制阀网 [www.cv3000.com](http://www.cv3000.com)

	API6A Ball-Side Entry					API6A Ball-Top Entry					API6A Check-Swing					API6A Gate-Thru Conduit				API6A Globe							
	FLANGED-HUBS					FLANGED-HUBS					FLANGED-HUBS					FLANGED-HUBS				FLANGED-HUBS							
	#3000	#5000	#10000	#15000	#20000	#3000	#5000	#10000	#15000	#20000	#3000	#5000	#10000	#15000	#20000	#3000	#5000	#10000	#15000	#3000	#5000	#10000	#15000				
1/2"-2" spec																											
1-13/16																											
2-1/16 52																											
2.9/16" 65																											
3-1/8 79																											
4-1/16 103																											
5-1/8 130																											
7 1/16" 179																											
9 228																											
11 279																											
13 5/8 346																											







# Catalogs

三千控制阀网 [www.cv3000.com](http://www.cv3000.com)

