

Finding valves that perform reliably in gasification applications has long been a challenge. With the CA-1AS metal-seated ball valve, MOGAS offers a field-tested solution.

The Problem: Poor Valve Performance

The severe-service operating conditions associated with lockhopper service in a quench-chamber gasification unit — corrosive, high-ash content feeds, high temperatures and high pressures — have caused problems for valves for many years. In the past, inconsistent valve performance has led to millions of dollars of lost production due to unscheduled, valve-related shutdowns.

The MOGAS Solution: A Better Ball Valve

While metal-seated floating ball valves remained an excellent choice for lockhopper service, such performance showed a clear need for additional design improvements. MOGAS moved to meet this need by developing the CA-1AS severe service valve — the ideal solution for lockhopper service.

Up to 100,000 Cycles and 5 Years of Service

Working extensively with the leading licensor of gasification technology, MOGAS made design improvements (to seat configuration, weld inlays and coatings) that have stood the test of time. The CA-1AS valve used in lockhopper service endures extensive cycle counts (up to 100,000) and severe operating conditions to provide gasification units with up to five years of reliable, uninterrupted service.

Quench-Chamber Gasification System

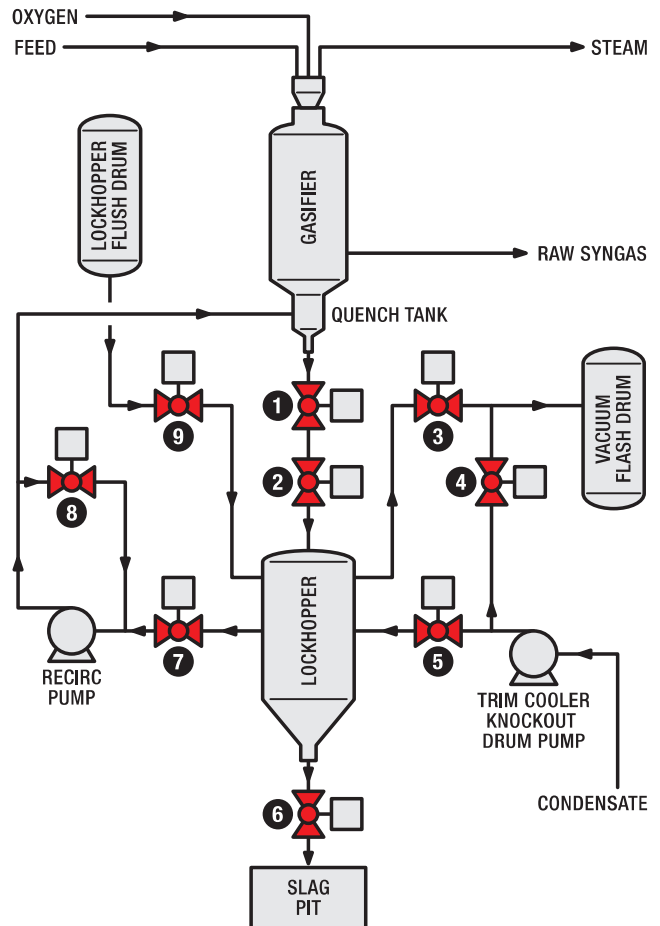

Once installed, MOGAS valves provide up to five years of uninterrupted service and up to 100,000 cycles of operation.

Valve Specification

Valve Number	Valve Description
1	Lockhopper Inlet 1
2	Lockhopper Inlet 2
3	Lockhopper Vent
4	Lockhopper Vent Purge
5	Lockhopper Pressuring
6	Lockhopper Outlet
7	Recirc Pump Suction
8	Recirc Pump Kickback
9	Lockhopper Flush