

NELES® TRUNNION MOUNTED BALL VALVE – SERIES D

Metso's Neles series D is a trunnion mounted ball valve for demanding on/off and control applications. Valve series incorporates Metso's several decade experience of metal-to-metal seat technology, application based seat selection and overall robust construction.

Equipped with Metso B1 series actuator and VG9000 intelligent safety solenoid the valve assembly delivers high availability in demanding safety valve applications upto SIL 3.

For control applications valves can be equipped with top of the line rotary valve noise attenuation trim options - including the new Q2 trim for gas applications.

Valves are well suited in various of oil and gas, refining, petrochemical and chemical industries - conforming to today's demanding requires of safety and emissions.

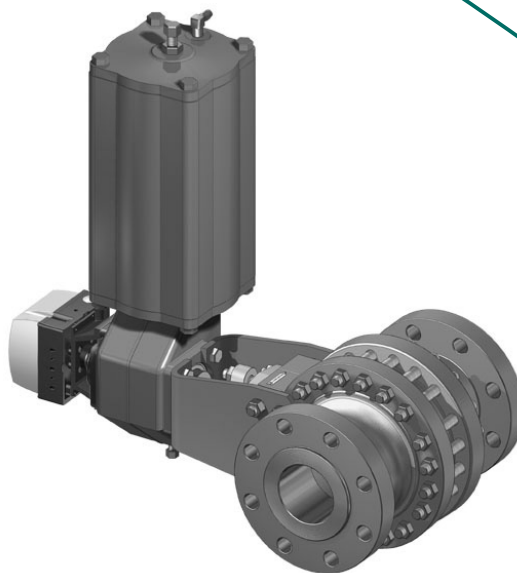

APPLICATIONS

- ESD / ESV service (upto SIL 3)
- HIPPS
- De-pressurizing and blow down service
- Low noise and anti-cavitation
- Cryogenic service
- High temperature service
- High cycle and switching service
- Oxygen construction for gaseous oxygen service
- Molecular sieves
- Solids handling
- Chemical and petrochemical plants
- Oil and gas production
- Steam
- Natural gas, LNG, LPG
- Power plant

DESIGN FEATURES

Size range

- NPS 02" – 36" (DN 50 – 900)

Pressure classes

- ASME Class 150, 300 and 600

Body design

- Full bore and reduced bore

Stemball

- Ball and stem of one piece
- No-dead band , no hysteresis in throttling service
- Reliable operation and excellent response even with high differential pressure

Trunnion mounted

- Good controllability
- Low friction and operating torque
- Large low friction bearings for long cycle life

Metal seats

- Spring loaded seats for continuous contact with ball
- Durable tightness with extensive selection of hard facings for different applications and fluids
- Two way tight with double seated design
- Double Block and Bleed seat design

Control service

- Excellent control characteristics
- Equal percentage inherent characteristic
- Full ball and two throttling stages reduces cavitation and noise
- Self flushing low noise anti-cavitation Q-trim.
- High noise reduction Q2-trim for gas applications
- High rangeability

ESD service

- D series valves are certified to be used safety systems up to and including SIL 3.
- Full ESD package from single source supplier; valve, actuator and automated PST device VG9000 series. All components are certified to be used up to SIL 3.
- Possibility of on-line condition monitoring and diagnostics of safety valve assembly
- Valve design makes it suitable for solids and fibrous fluids

EXPLODED VIEWS AND LISTS OF PARTS

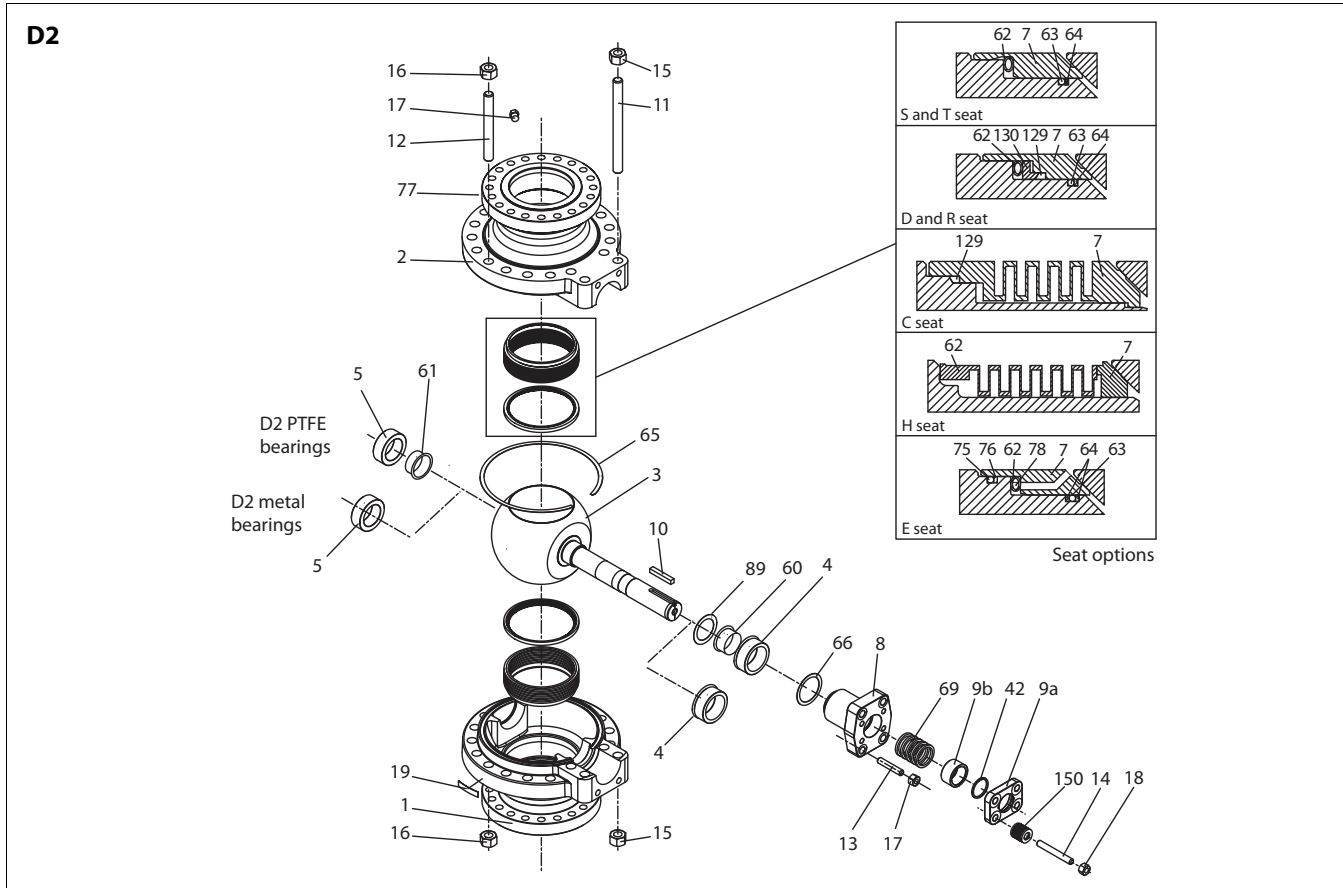

Item	Part description	Material	
1	Body half (female)	Stainless steel, ASTM A 351 gr. CF8M	Carbon steel, ASTM A 216 gr. WCB
2	Body half (male)	Stainless steel, ASTM A 351 gr. CF8M	Carbon steel, ASTM A 216 gr. WCB
3	Ball	Stainless steel, ASTM A 351 gr. CF8M + Hard chrome	
4	Trunnion bearing	Stainless steel, AISI 316 (Cobalt based alloy bushing in high temperature construction)	
5	Trunnion bearing	Stainless steel, AISI 316 (Cobalt based alloy bushing in high temperature construction)	
7	Ball seat	Stainless steel, AISI 316 + Cobalt based alloy	
8	Bonnet	Stainless steel, ASTM A 351 gr. CF8M	Carbon steel, ASTM A 216 gr. WCB
9a	Gland	Stainless steel, ASTM A 351 gr. CF8M	
9b	Compression sleeve	Stainless steel, ASTM A 351 gr. CF8M	
10	Key	Stainless steel, AISI 329	
11	Stud	ASTM A 193 gr. B8M	ASTM A 320 gr. L7M
12	Stud	ASTM A 193 gr. B8M	ASTM A 320 gr. L7M
13	Stud	ASTM A 193 gr. B8M	ASTM A 320 gr. L7M
14	Stud	ASTM A 193 gr. B8M	ASTM A 320 gr. L7M
15	Hexagon nut	ASTM A 194 gr. 8M	ASTM A 194 gr. 2HM
16	Hexagon nut	ASTM A 194 gr. 8M	ASTM A 194 gr. 2HM
17	Hexagon nut	ASTM A 194 gr. 8M	ASTM A 194 gr. 2HM
18	Hexagon nut	ASTM A 194 gr. 8M	ASTM A 194 gr. 2HM
19	Identification plate	Stainless steel, AISI 304	
42	Retainer ring	ASTM A 479 gr. XM-19	
60*	Bearing strip	PTFE on stainless steel net, standard construction	
61*	Bearing strip	PTFE on stainless steel net, standard construction	
62	Spring	Special alloy UNS N07750, in standard construction / gr. 660 / F6NM in high temperature construction	
63	O-ring	Viton GF	
64	Back-up ring	Polytetrafluoroethylene (PTFE)	
65	Seal strip	Graphite	
66	Sheet ring	Graphite	
69	Packing ring	Graphite + PTFE	
75	O-ring	Viton GF	
76	Back-up ring	PTFE	
77	Hexagon plug	Stainless steel, AISI 316	
78	Spring pin	Stainless steel	
89*	Thrust bearing	PTFE on stainless steel net	
129	Back seal	Graphite	
130	Set ring	Stainless steel, AISI 316	
150	Disc spring set	EN10088-1.8159 + ENP	

Note: * Only in PTFE bearing construction.

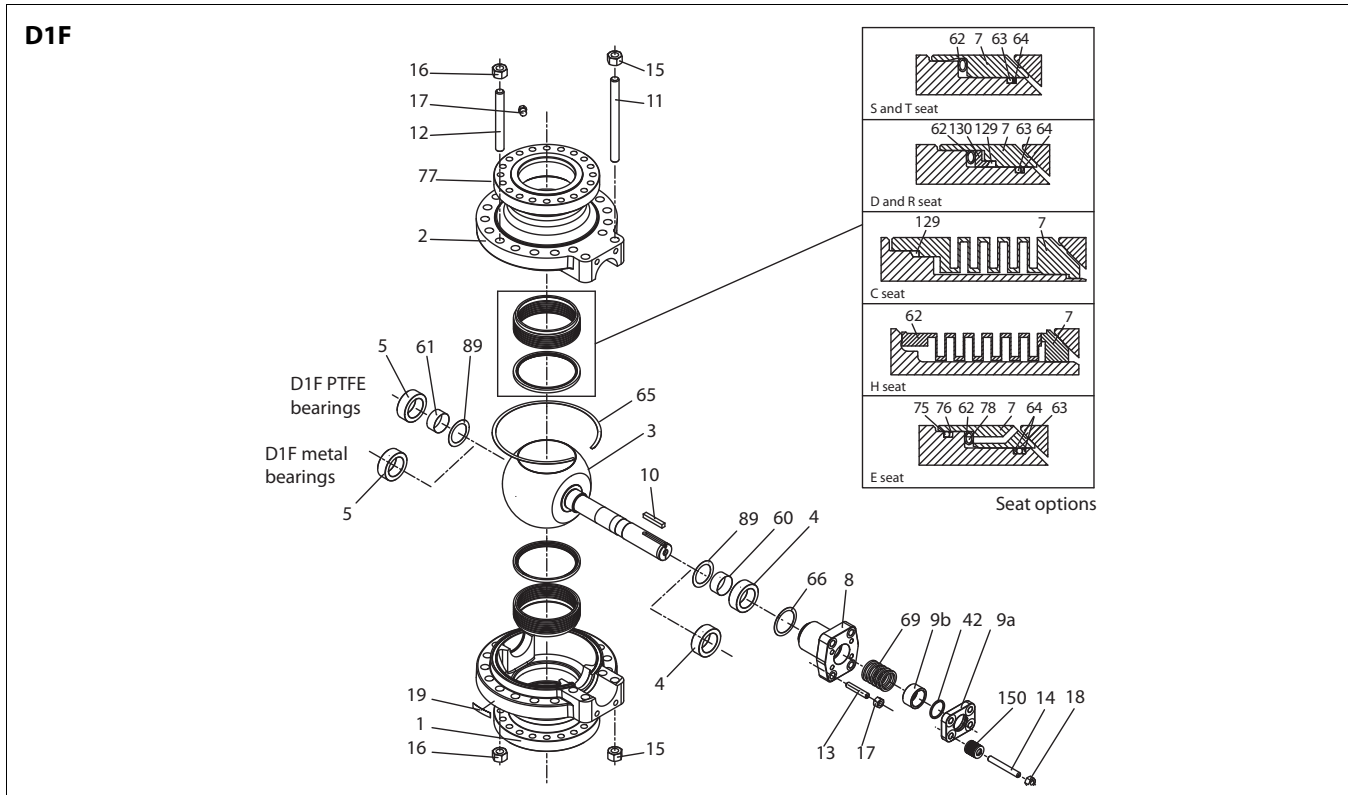

Item	Part description	Material	
1	Body half (female)	Stainless steel, ASTM A 351 gr. CF8M	Carbon steel, ASTM A 216 gr. WCB
2	Body half (male)	Stainless steel, ASTM A 351 gr. CF8M	Carbon steel, ASTM A 216 gr. WCB
3	Ball	Stainless steel, ASTM A 351 gr. CF8M + Hard chrome	
4	Trunnion bearing	Stainless steel, AISI 316 (Cobalt based alloy bushing in high temperature construction)	
5	Trunnion bearing	Stainless steel, AISI 316 (Cobalt based alloy bushing in high temperature construction)	
7	Ball seat	Stainless steel, AISI 316 + Cobalt based alloy	
8	Bonnet	Stainless steel, ASTM A 351 gr. CF8M	Carbon steel, ASTM A 216 gr. WCB
9a	Gland	Stainless steel, ASTM A 351 gr. CF8M	
9b	Compression sleeve	Stainless steel, ASTM A 351 gr. CF8M	
10	Key	Stainless steel, AISI 329	
11	Stud	ASTM A 193 gr. B8M	ASTM A 320 gr. L7M
12	Stud	ASTM A 193 gr. B8M	ASTM A 320 gr. L7M
13	Stud	ASTM A 193 gr. B8M	ASTM A 320 gr. L7M
14	Stud	ASTM A 193 gr. B8M	ASTM A 320 gr. L7M
15	Hexagon nut	ASTM A 194 gr. 8M	ASTM A 194 gr. 2HM
16	Hexagon nut	ASTM A 194 gr. 8M	ASTM A 194 gr. 2HM
17	Hexagon nut	ASTM A 194 gr. 8M	ASTM A 194 gr. 2HM
18	Hexagon nut	ASTM A 194 gr. 8M	ASTM A 194 gr. 2HM
19	Identification plate	Stainless steel, AISI 304	
42	Retainer ring	ASTM A 479 gr. XM-19	
60*	Bearing strip	PTFE on stainless steel net, standard construction	
61*	Bearing strip	PTFE on stainless steel net, standard construction	
62	Spring	Special alloy UNS N07750, in standard construction / gr. 660 / F6NM in high temperature construction	
63	O-ring	Viton GF	
64	Back-up ring	Polytetrafluoroethylene (PTFE)	
65	Seal strip	Graphite	
66	Sheet ring	Graphite	
69	Packing ring	Graphite + PTFE	
75	O-ring	Viton GF	
76	Back-up ring	PTFE	
77	Hexagon plug	Stainless steel, AISI 316	
78	Spring pin	Stainless steel	
89*	Thrust bearing	PTFE on stainless steel net	
129	Back seal	Graphite	
130	Set ring	Stainless steel, AISI 316	
150	Disc spring set	EN10088-1.8159 + ENP	

Note: * Only in PTFE bearing construction.

TECHNICAL SPECIFICATION

Product type

Full or reduced bore, trunnion mounted ball valve.
Ball and stem are integrally cast.
Split body design.
Flanged.

Pressure ratings

ASME Class 150, 300 and 600.

Size range, full bore

DN 300 ... 900 / 12" - 36" in ASME Class 150.
DN 100 ... 900 / 4" - 36" in ASME Class 300.
DN 50 ... 600 / 2" - 28" in ASME Class 600.

Size range, reduced bore

DN 250 ... 600 / 10" - 24" in ASME Class 150.
DN 200 ... 600 / 8" - 24" in ASME Class 300.
DN 80 ... 600 / 3" - 24" in ASME Class 600.
Larger sizes on request.

Temperature range

-200 ... +450 °C (+600 °C)
-330 ... +840 °F (+1100 °F).

Design standards

Valve body ASME B16.34.
Valve body joint ASME VIII. DIV. 1 APPX 2.
Valve flanges ASME B16.5.
Face-to-face ASME B16.10.

Standard materials

Body ASTM A351 gr. CF8M.
ASTM A216 gr. WCB.
Ball ASTM A351 gr. CF8M + hard chrome or other special coating with metal seats.
Bearings SS 316 + PTFE net or Cobalt based alloy
Seats AISI 316 + Cobalt based alloy.
AISI 316 + PTFE insert.
Seals/gaskets PTFE, graphite.

Standard bearing construction

Large, low friction bearings.
SS 316 + PTFE net or Cobalt based alloy.

Emissions

ISO 15848-1 type approved and certified

Bolting

B8M/8M with stainless steel body.
L7M/2H or 2MH with carbon steel body.

Standard options

Cryogenic design.
Bonnet extension.
Oxygen construction for gaseous oxygen service.
High temperature design.
Carbide hard facing or NiBo ball coating.
Noise/cavitation reduction ball insert; Q-trim design.
Fire safety BS 6755/API 607 (on selected seat designs).
NACE MR-01-03 or MR-01-75.

Material and test certification

EN 10204-3.1 material certificates for body, ball and bonnet.

Valve tightness

ANSI/FCI 70-2 class V for metal seats.
ANSI/FCI 70-2 class VI for soft seats
ISO 5208 rate C or D for metal seats.
ISO 5208 rate B for soft seats.
Other tightness rates upon request.

Maximum allowable differential pressure curves

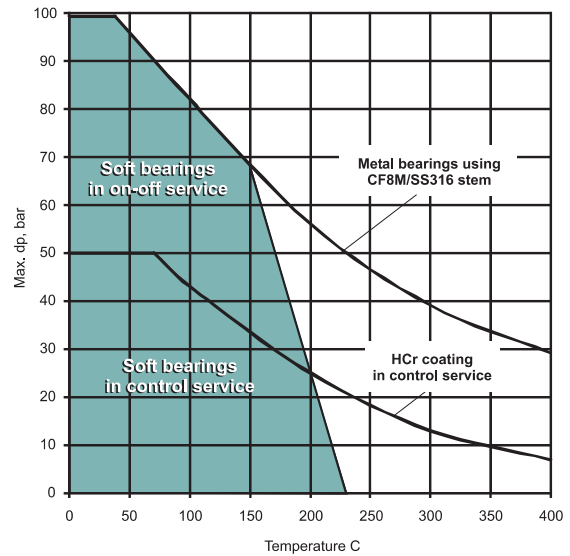

Maximum pressure/Temperature limitations on valve body according to ASME B16.34

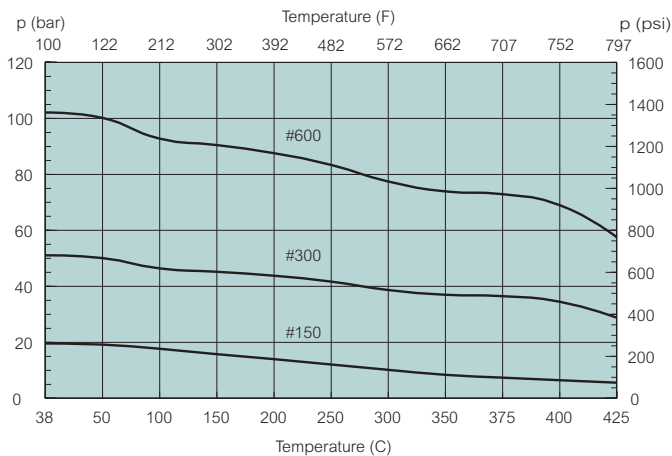

Material ASTM A216 gr. WCB.

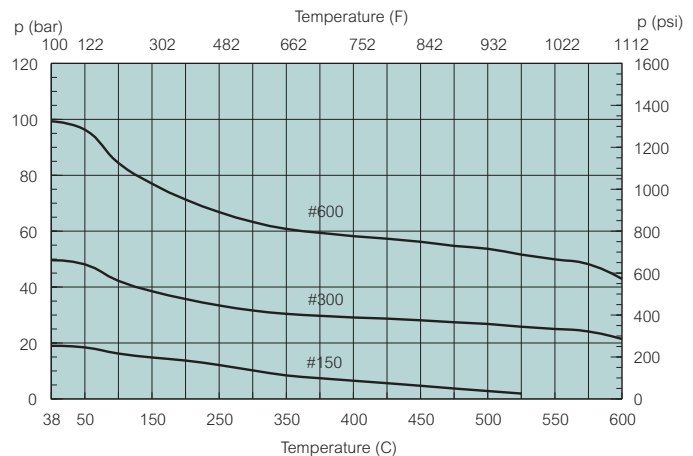

Material ASTM A351 gr. CF8M.

STANDARD SEAT SELECTION FOR D SERIES VALVES

Soft seat design, seat code T

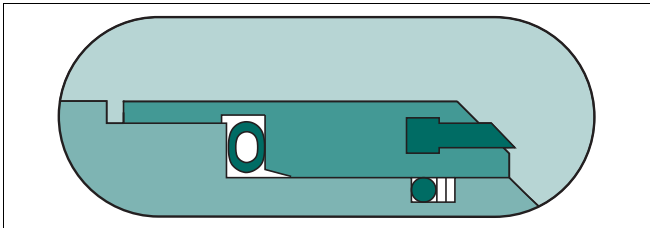

Size range: DN 50 ... 900 / 2" ... 36"
 Seat material: AISI 316 + PTFE + C25 % insert
 O-ring: Viton GF
 Spring: UNS N07750
 Temperature range: -30 ... +200 °C / -22 ... +390 °F.

The standard PTFE-seated design is most suitable for shut-off service, for temperatures up to +200 °C/+390 °F and when pressure drop is relatively low and medium does not contain wearing particles.

Low and high temperature on-off and control metal seat, seat code C

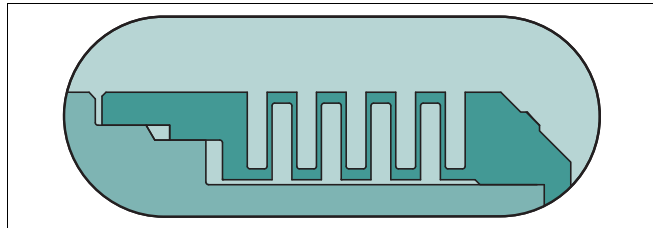

Size range: DN 50 ... 600 / 2" ... 24"
 Seat seal: Graphite
 Bellows seat material: gr. 660/F6NM + hard facing
 Temperature range: -200 ... +400 °C (+600 °C) /
 -330 ... +750 °F (+1110 °F).

The Cobalt based alloy seat is preloaded with a bellows ring made of special stainless steel. The bellows acts as a spring and seal, and also increases the seat pressure at higher pressure differentials. Designed for demanding applications containing impurities. Alternative bellows spring materials are available for temperatures up to +600 °C / +1110 °F. The bellows seat design is the choice for cryogenic service.

Metal seated design, seat code S

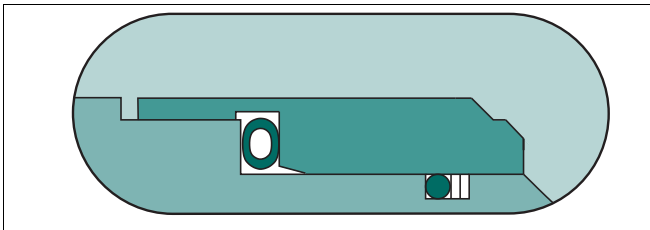

Size range: DN 50 ... 900 / 2" ... 36"
 Seat material: AISI 316 + Cobalt based alloy.
 O-ring: Viton GF
 Spring: UNS N07750
 Temperature range: -30 ... +200 °C / -22 ... +390 °F.

The metal seat is most suitable for high pressure drop applications and for fluids containing impurities.

Fire safe soft seat design, seat code D

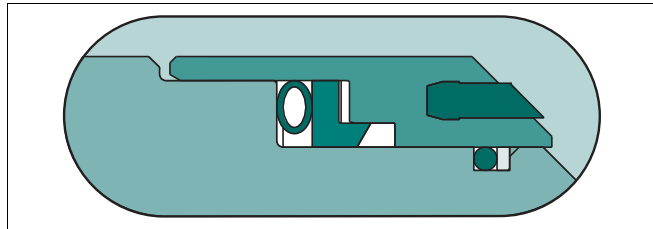

Size range: DN 50 ... 900 / 2" ... 36"
 Seat material: AISI 316 + PTFE + C25 % insert
 Seat seal: Viton GF / graphite
 Spring: UNS N07750
 Temperature range: -30 ... +200 °C / -22 ... +390 °F.

The fire safe PTFE-seated design is most suitable for shut-off service, for temperatures up to +200 °C/+390 °F and when pressure drop is relatively low and medium does not contain wearing particles.

Control metal seat design, seat code E

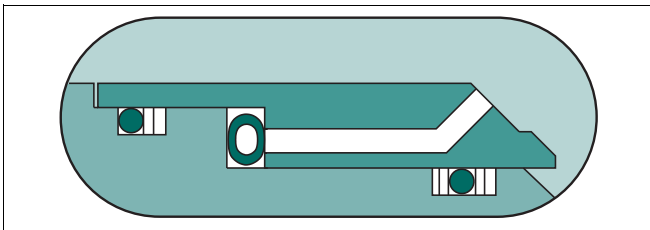

Size range: DN 50 ... 900 / 2" ... 36"
 Seat material: AISI 316 + Cobalt based alloy.
 O-ring: Viton GF
 Spring: UNS N07750
 Temperature range: -30 ... +200 °C / -22 ... +390 °F.

The control metal seat features the ejector seat principle providing non-contact in control service.

This seat design is intended for demanding control applications.

Fire safe on-off metal seated design, seat code R

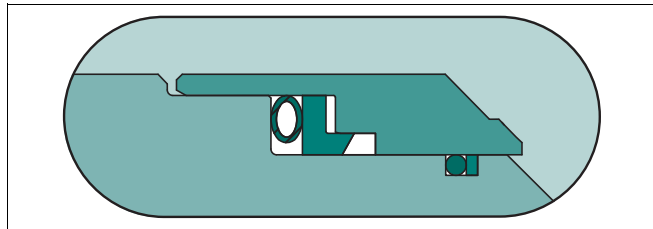

Size range: DN 50 ... 900 / 2" ... 36"
 Seat material: AISI 316 + Cobalt based alloy.
 Seat seal: Viton GF / graphite
 Spring: UNS N07750
 Temperature range: -30 ... +200 °C / -22 ... +390 °F.

The fire safe metal seat is most suitable for high pressure drop applications and for fluids containing impurities.

DIMENSIONS AND WEIGHTS

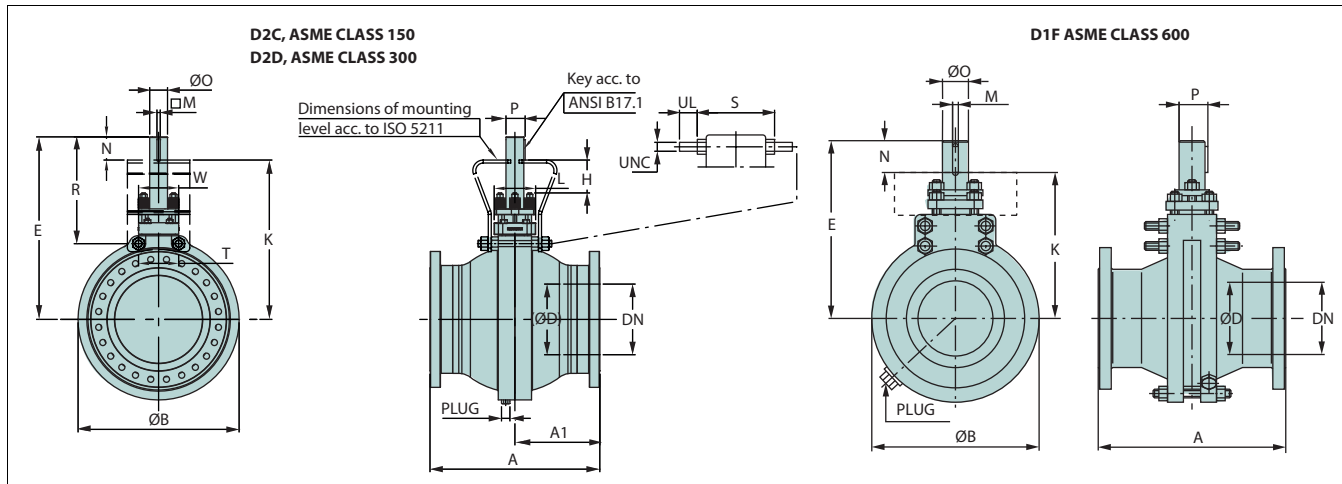

D2C, ASME CLASS 150

Type	Dimensions, mm										Cv 90°	ζ 90°	Mounting face	Plug NPTF	kg
	DN	A	ØB	ØD	E	K	M	N	ØO	P					
D2C 12	300	610	596	304	756	600	22.22	156	95	104.8	22400	0.04	F16, F25, F30	1	420
D2C 14	350	686	668	337	818	662	22.22	156	95/105	104.8	28300	0.04	F16, F25, F30	1	550
D2C 16	400	762	744	387	840	684	22.22	156	95/120	104.8	37700	0.04	F16, F25, F30	1	720
D2C 18	450	864	814	440	890	734	22.22	156	95/120	104.8	48000	0.03	F16, F25, F30	1	1300
D2C 20	500	914	904	490	969	789	25.40	180	95/105	116.1	59500	0.03	F16, F25, F30, F35	1	1500
D2C 24	600	1067	1084	590	1128	923	31.75	205	95/120	133.8	86300	0.03	F25, F30, F35, F40	1	2300
D2C 28	700	1244	1245	692	1263	1038	31.75	225	105/135	149	118000	0.03	F30, F35, F40	1	3800
D2C 30	750	1295	1318	740	1485	1235	38.10	250	150	166.6	136000	0.03	F30, F35, F40	1	4400
D2C 36	900	1524	1560	880	1661	1381	38.10	280	165	181.8	192000	0.03	F40, F48	1	6500

Type	Dimensions, inch										Cv 90°	ζ 90°	Mounting face	Plug NPTF	lb
	Size	A	ØB	ØD	E	K	M	N	ØO	P					
D2C 12	12	24.02	23.46	11.97	29.76	23.62	0.87	6.14	3.74	4.13	22400	0.04	F16, F25, F30	1	924
D2C 14	14	27.01	26.30	13.27	32.20	26.06	0.87	6.14	3.74/4.13	4.13	28300	0.04	F16, F25, F30	1	1210
D2C 16	16	30.00	29.29	15.24	33.07	26.93	0.87	6.14	3.74/4.72	4.13	37700	0.04	F16, F25, F30	1	1584
D2C 18	18	34.02	32.05	17.32	35.04	28.90	0.87	6.14	3.74/4.72	4.13	48000	0.03	F16, F25, F30	1	2860
D2C 20	20	35.98	35.59	19.29	38.15	31.06	1.00	7.09	3.74/4.13	4.57	59500	0.03	F16, F25, F30, F35	1	3300
D2C 24	24	42.01	42.68	23.23	44.41	36.34	1.25	8.07	3.74/4.72	5.27	86300	0.03	F25, F30, F35, F40	1	5060
D2C 28	28	48.98	49.02	27.24	49.72	40.87	1.25	8.86	4.13/5.31	5.87	118000	0.03	F30, F35, F40	1	8360
D2C 30	30	50.98	51.89	29.13	58.46	48.62	1.50	9.84	5.91	6.56	136000	0.03	F30, F35, F40	1	9680
D2C 36	36	60.00	61.42	34.65	65.39	54.37	1.50	11.02	6.50	7.16	192000	0.03	F40, F48	1	14300

Valve-actuator assembly dimensions:
See K-dimension from drawing, mounting face from table and actuator dimensions from related actuator bulletin.

D2D, ASME CLASS 300

Type	Dimensions, mm										Cv 90°	ζ 90°	Mounting face	Plug NPTF	kg
	DN	A	ØB	ØD	E	K	M	N	ØO	P					
D2D 04	100	305	262	100	373	305	9.52	68	40	44.2	2120	0.05	F10, F12, F14	1/2	60
D2D 06	150	403	368	152	480	390	12.70	90	55	60.6	5100	0.05	F12, F14, F16	3/4	140
D2D 08	200	502	454	202	575	456	19.05	119	70	78.2	9300	0.04	F14, F16, F25	3/4	240
D2D 10	250	568	558	254	684.5	538.5	22.22	146	85	94.6	15200	0.04	F16, F25, F30	1	380
D2D 12	300	648	630	304	756	600	22.22	156	95	104.8	22400	0.04	F16, F25, F30, F35	1	590
D2D 14	350	762	706	337	818	638	25.40	180	105	116.2	28300	0.04	F25, F30, F35	1	770
D2D 16	400	838	792	387	910.5	705.5	31.75	205	120	133.8	37700	0.04	F25, F30, F35	1	1050
D2D 18	450	914	884	440	1005	849	22.22	156	95	104.8	48000	0.03	F25, F30, F35	1	1250
D2D 20	500	991	966	490	1085	905	25.40	180	105	116.2	59500	0.03	F25, F30, F35, F40	1	1950
D2D 24	600	1143	1130	590	1229	1024	31.75	205	120	133.8	86300	0.03	F30, F35, F40	1	3100
D2D 28	700	1346	1340	690	1323	1098	31.75	225	135	149	118000	0.03	F35, F40	1	5250
D2D 30	750	1397	1414	740	1485	1235	38.10	250	150	166.6	136000	0.03	F35, F40, F48	1	5500
D2D 32	800	1524	1490	785	1521	1271	38.10	250	150	166.6	151000	0.03	F35, F40	1	6700
D2D 36	900	1727	1684	880	1720	1440	38.10	280	165	181.8	192000	0.03	F40, F48	1	8700

Type	Dimensions, inch										Cv 90°	ζ 90°	Mounting face	Plug NPTF	lb
	Size	A	ØB	ØD	E	K	M	N	ØO	P					
D2D 4	4	12.01	10.31	3.94	14.69	12.01	0.37	2.68	1.57	1.74	2120	0.05	F10, F12, F14	1/2	132
D2D 6	6	15.87	14.49	5.98	18.90	15.35	0.50	3.54	2.17	2.39	5100	0.05	F12, F14, F16	3/4	308
D2D 8	8	19.76	17.87	7.95	22.64	17.95	0.75	4.69	2.76	3.08	9300	0.04	F14, F16, F25	3/4	528
D2D 10	10	22.36	21.97	10.00	26.95	21.20	0.87	5.75	3.35	3.72	15200	0.04	F16, F25, F30	1	836
D2D 12	12	25.51	24.80	11.97	29.76	23.62	0.87	6.14	3.74	4.13	22400	0.04	F16, F25, F30, F35	1	1298
D2D 14	14	30.00	27.80	13.27	32.20	25.12	1.00	7.09	4.13	4.57	28300	0.04	F25, F30, F35	1	1694
D2D 16	16	32.99	31.18	15.24	35.85	27.78	1.25	8.07	4.72	5.27	37700	0.04	F25, F30, F35	1	2310
D2D 18	18	35.98	34.80	17.32	39.57	33.43	0.87	6.14	3.74	4.13	48000	0.03	F25, F30, F35	1	2750
D2D 20	20	39.02	38.03	19.29	42.72	35.63	1.00	7.09	4.13	4.57	59500	0.03	F25, F30, F35, F40	1	4290
D2D 24	24	45.00	44.49	23.23	48.39	40.31	1.25	8.07	4.72	5.27	86300	0.03	F30, F35, F40	1	6820
D2D 28	28	52.99	52.76	27.17	52.09	43.23	1.25	8.86	5.31	5.87	118000	0.03	F35, F40	1	11550
D2D 30	30	55.00	55.67	29.13	58.46	48.62	1.50	9.84	5.91	6.56	136000	0.03	F35, F40, F48	1	12100
D2D 32	32	60.00	58.66	30.90	59.88	50.04	1.50	9.84	5.91	6.56	151000	0.03	F35, F40	1	14740
D2D 36	36	68.00	66.30	34.65	67.72	56.69	1.50	11.02	6.50	7.16	192000	0.03	F40, F48	1	19140

D1F, ASME CLASS 600

Type	Dimensions, mm										Cv 90°	ζ 90°	Mounting face	Plug NPTF	kg
	DN	A	ØB	ØD	E	K	M	N	ØO	P					
D1F 02	50	292	206	50	305	300	6.35	46	25	27.8	480	0.06	F07, F10, F12, F14	1/2	35
D1F 03	80	356	262	77	375	340	9.52	58	35	39.1	1200	0.05	F12, F14, F16	1/2	60
D1F 04	100	432	314	100	427	387	9.52	68	40	44.2	2120	0.05	F14, F16, F25	1/2	120
D1F 06	150	559	404	152	540	485	12.70	90	55	60.6	5100	0.05	F14, F16, F25, F30	3/4	280
D1F 08	200	660	507	202	645	575	19.05	119	70	78.2	9300	0.04	F14, F16, F25, F30	3/4	380
D1F 10	250	787	610	254	765	680	22.22	146	85	94.6	15200	0.04	F16, F25, F30, F35	1	690
D1F 12	300	838	748	302	890	795	22.22	156	95	104.8	22400	0.04	F25, F30, F35, F40	1	1134
D1F 14	350	889	824	340	970	865	25.40	180	105	116.1	28300	0.04	F25, F30, F35, F40	1	1500
D1F 16	400	991	954	390	1068	948	31.75	205	120	133.8	37700	0.04	F30, F35, F40	1	2500
D1F 18	450	1092	1090	440	1200	1065	31.75	225	135	149.0	48000	0.03	F30, F35, F40	1	3300
D1F 20	500	1194	1176	490	1355	1205	38.10	250	150	166.6	59500	0.03	F35, F40, F48	1	3880
D1F 24	600	1397	1224	591	1440	1275	38.10	280	165	181.8	86300	0.03	F35, F40, F48	1	6500

Type	Dimensions, inch										Cv 90°	ζ 90°	Mounting face	Plug NPTF	lb
	Size	A	ØB	ØD	E	K	M	N	ØO	P					
D1F 2	2	11.50	8.11	1.97	12.01	11.81	0.25	1.81	0.98	1.09	480	0.06	F07, F10, F12, F14	1/2	77
D1F 3	3	14.02	10.31	3.03	14.76	13.39	0.37	2.28	1.38	1.54	1200	0.05	F12, F14, F16	1/2	132
D1F 4	4	17.01	12.36	3.94	16.81	15.24	0.37	2.68	1.57	1.74	2120	0.05	F14, F16, F25	1/2	264
D1F 6	6	22.01	15.91	5.98	21.26	19.09	0.50	3.54	2.17	2.39	5100	0.05	F14, F16, F25, F30	3/4	616
D1F 8	8	25.98	19.96	7.95	25.39	22.64	0.75	4.69	2.76	3.08	9300	0.04	F14, F16, F25, F30	3/4	836
D1F 10	10	30.98	24.02	10.00	30.12	26.77	0.87	5.75	3.35	3.72	15200	0.04	F16, F25, F30, F35	1	1518
D1F 12	12	32.99	29.45	11.89	35.04	31.30	0.87	6.14	3.74	4.13	22400	0.04	F25, F30, F35, F40	1	2495
D1F 14	14	35.00	32.44	13.39	38.19	34.06	1.00	7.09	4.13	4.57	28300	0.04	F25, F30, F35, F40	1	3300
D1F 16	16	39.02	37.56	15.35	42.05	37.32	1.25	8.07	4.72	5.27	37700	0.04	F30, F35, F40	1	5500
D1F 18	18	42.99	42.91	17.32	47.24	41.93	1.25	8.86	5.31	5.87	48000	0.03	F30, F35, F40	1	7260
D1F 20	20	47.01	46.30	19.29	53.35	47.44	1.50	9.84	5.91	6.56	59500	0.03	F35, F40, F48	1	8536
D1F 24	24	55.00	48.19	23.27	56.69	50.20	1.50	11.02	6.50	7.16	86300	0.03	F35, F40, F48	1	14300

Valve-actuator assembly dimensions:
See K-dimension from drawing, mounting face from table and actuator dimensions from related actuator bulletin.

VALVE + B1C/B1J/B1JA

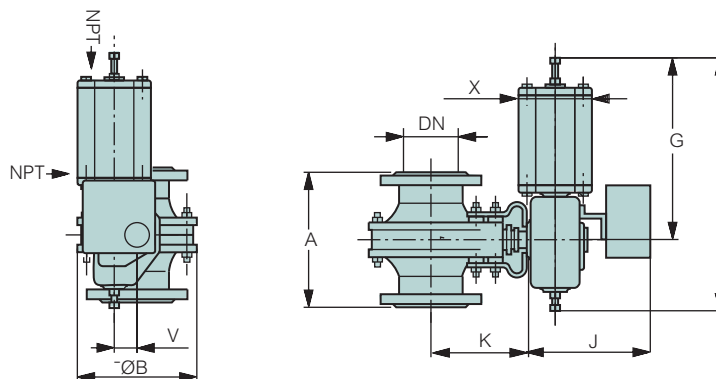

B1C ACTUATOR

Actuator	DIMENSIONS, mm					NPT	kg
	F	G	J	V	X		
B1C6	400	260	283	36	90	1/4	4.2
B1C9	455	315	279	43	110	1/4	9.6
B1C11	540	375	290	51	135	3/8	16
B1C13	635	445	316	65	175	3/8	31
B1C17	770	545	351	78	215	1/2	54
B1C20	840	575	385	97	215	1/2	73
B1C25	1040	710	448	121	265	1/2	131
B1C32	1330	910	525	153	395	3/4	256
B1C40	1660	1150	595	194	505	3/4	446
B1C50	1970	1350	690	242	610	1	830

Actuator	DIMENSIONS, inch					NPT	lbs
	F	G	J	V	X		
B1C6	15.75	10.24	11.14	1.42	3.54	1/4	9
B1C9	17.91	12.40	10.98	1.69	4.33	1/4	21
B1C11	21.26	14.76	11.42	2.01	5.31	3/8	35
B1C13	25.00	17.52	12.44	2.56	6.89	3/8	68
B1C17	30.31	21.46	13.82	3.07	8.46	1/2	119
B1C20	33.07	22.64	15.16	3.82	8.46	1/2	161
B1C25	40.94	27.95	17.64	4.76	10.43	1/2	289
B1C32	52.36	35.83	20.67	6.02	15.55	3/4	564
B1C40	65.35	45.28	23.43	7.64	19.88	3/4	983
B1C50	77.56	53.15	27.17	9.53	24.02	1	1829

B1J ACTUATOR

Actuator	DIMENSIONS, mm					NPT	kg
	F	G	J	V	X		
B1J/B1JA6	485	368	273	36	110	3/8	8
B1J/B1JA8	560	420	279	43	135	3/8	17
B1J/B1JA10	650	490	290	51	175	3/8	30
B1J/B1JA12	800	620	316	65	215	1/2	57
B1J/B1JA16	990	760	351	78	265	1/2	100
B1J/B1JA20	1200	935	358	97	395	3/4	175
B1J/B1JA25	1530	1200	448	121	505	3/4	350
B1J/B1JA32	1830	1410	525	153	540	1	671

Actuator	DIMENSIONS, inch					NPT	lbs
	F	G	J	V	X		
B1J/B1JA6	19.09	14.49	10.75	1.42	4.33	3/8	20
B1J/B1JA8	22.05	16.54	10.98	1.69	5.31	3/8	37
B1J/B1JA10	25.59	19.29	11.42	2.01	6.89	3/8	66
B1J/B1JA12	31.50	24.41	12.44	2.56	8.46	1/2	126
B1J/B1JA16	38.98	29.92	13.82	3.07	10.43	1/2	220
B1J/B1JA20	47.24	36.81	14.09	3.82	15.55	3/4	386
B1J/B1JA25	60.24	47.24	17.64	4.76	19.88	3/4	771
B1J/B1JA32	72.05	55.51	20.67	6.02	21.26	1	1479

HOW TO ORDER

Q	1.	2.	3.	4.	5.	6.	7.	8.	9.	10.	11.	
-	D1	F	E	06	D	A	E	02	G	/	-	P

Q	Q-CODE PRODUCT OPTIONS
Q	Standard low noise trim for gas and liquid application, single seated (const. E or B) with open down stream side ball surface
Q2G	Q2-trim for gas application (single seated const. E or B)
Q-CODE SPECIAL PRODUCT OPTIONS	
Q	Standard low noise trim for gas and liquid application, double seated (construction A or H), ball with solid two sealing surfaces
QLM	Partial baffle inside the ball for increased cavitation resistance.

1.	SERIES
D	Center split body, trunnion mounted, bonnet
D2, D1(F)	Full bore, flanged
D3	Full bore, weld ends
D4	Reduced bore, weld ends
D5	Reduced bore, flanged

2.	PRESSURE RATING
C	ASME class 150
D	ASME class 300
F	ASME class 600

3.	CONSTRUCTION
A	General construction, PTFE bearings, 2 seats, temperature range: -50 ... +230 °C.
B	Single seated, one-way tight, metal bearings, temperature range: -50 ... +450/600 °C
E	Single seated, one-way tight, PTFE bearings, temperature range: -50 ... +230 °C
H	High-temperature construction, metal bearings, 2 seats, temperature range: -50 ... +450/600 °C
C	Cryogenic construction, PTFE bearings, temperature range: -200 ... +230 °C
Z	Oxygen construction BAM tested non-metallic materials - T = -50 ... +200 °C - Max pressure based on body rating - Metal bearings, cobalt based alloy - 2 seats, seat type C, WC-Co coated ball and seats (other seat types shall be consulted with Product Center) - Oxygen cleaning acc. to Metso internal procedure T-2115
Y	Special construction

4.	SIZE (in)
D1F	02, 03, 04, 06, 08, 10, 12, 14, 16, 18, 20, 24, 28
D2D	04, 06, 08, 10, 12, 14, 16, 18, 20, 24, 28*, 30*, 32*, 36*
D2C	10, 12, 14, 16, 18, 20, 24, 28*, 30*, 36*

*) Flanges acc. to ASME B16.47 series A in sizes 26" or larger.
Flanges in sizes up to NPS 24" are acc. to ASME B 16.5.

5.	BODY	BOLTING
STANDARD MATERIALS		
A	CF8M	B8M / 8M
D	WCB	L7M / 2HM
Y	Special	

6.	BALL
A	CF8M / AISI 316 + Chrome
D	CF8M / AISI 316 + NiBo, only size ≤ 24
H	CA6NM + Chrome
H3	CA6NM + CrC, general service up to + 425 °C
R3	CF8M / AISI 316 + CrC, high temperature
Y	Special

7.	SEAT TYPE
T	Soft seat
D	Soft seat, fire safe
S	Metal seat
E	Metal seat
C	Bellows seat
K	Solids proof metal seat
R	Fire safe metal seat

8.	STANDARD MATERIAL				
	Seat seal	Body gasket	Gland packing	Wound spring or bellows spring	
02	Viton GF	Graphite	Graphite	W	X-750
03		Graphite Graphite	Graphite Graphite	B W	W.no.1.4418 X-750
18	Graphite	Graphite	Graphite	B	gr. 660/F6NM
NON-STANDARD MATERIALS					
63	Viton GF, graphite	Graphite	Graphite	W	X-750

9.	PACKING CONSTRUCTION CODE
G	Standard packing, live loaded graphite packing, ISO 15848-1 certified
-	Non-live loaded packing

10.	FLANGE FACING
-	ASME B16.5 raised face Ra 3.2-6.3 or EN 1092-1 Type B1 (Ra 3.2-12.5) up to PN 40, type B2 in PN 63, 100
05	Ring Joint

11.	FLANGE
-	Acc. to valve pressure rating, without sign (standard)
C	ASME class 150***
D	ASME class 300***
F	ASME class 600***
J	EN PN 10
K	EN PN 16
L	EN PN 25
M	EN PN 40
N	EN PN 63
P	EN PN 100
R	JIS 10K
S	JIS 16K
T	JIS 20K
U	JIS 30K
W	JIS 40K
Y	Special

***) Flange acc. to ASME B16.47 series A in sizes 26" or larger.
Flange in sizes up to NPS 24" are acc. to ASME B 16.5

Subject to change without prior notice.

Metso Flow Control Inc.

Europe, Vanha Porvoontie 229, P.O. Box 304, FI-01301 VANTAA, Finland.
Tel. +358 20 483 150. Fax +358 20 483 151

North America, 44 Bowditch Drive, P.O. Box 8044, Shrewsbury, MA 01545, USA.
Tel. +1 508 852 0200. Fax +1 508 852 8172

South America, Av. Independência, 2500- Iporanga, 18087-101, Sorocaba-São Paulo, Brazil.
Tel. +55 15 2102 9700. Fax +55 15 2102 9748/49

Asia Pacific, Haw Par Centre #06-01, 180 Clemenceau Avenue, Singapore 239922.
Tel. +65 6511 1011. Fax +65 6250 0830

China, 11/F, China Youth Plaza, No.19 North Rd of East 3rd Ring Rd, Chaoyang District,
Beijing 100020, China. Tel. +86 10 6566 6600. Fax +86 10 6566 2583.

Middle East, Roundabout 8, Unit AB-07, P.O. Box 17175, Jebel Ali Freezone, Dubai,
United Arab Emirates. Tel. +971 4 883 6974. Fax +971 4 883 6836

www.metso.com/valves

