

CERA SYSTEM®

✓ more than ceramics

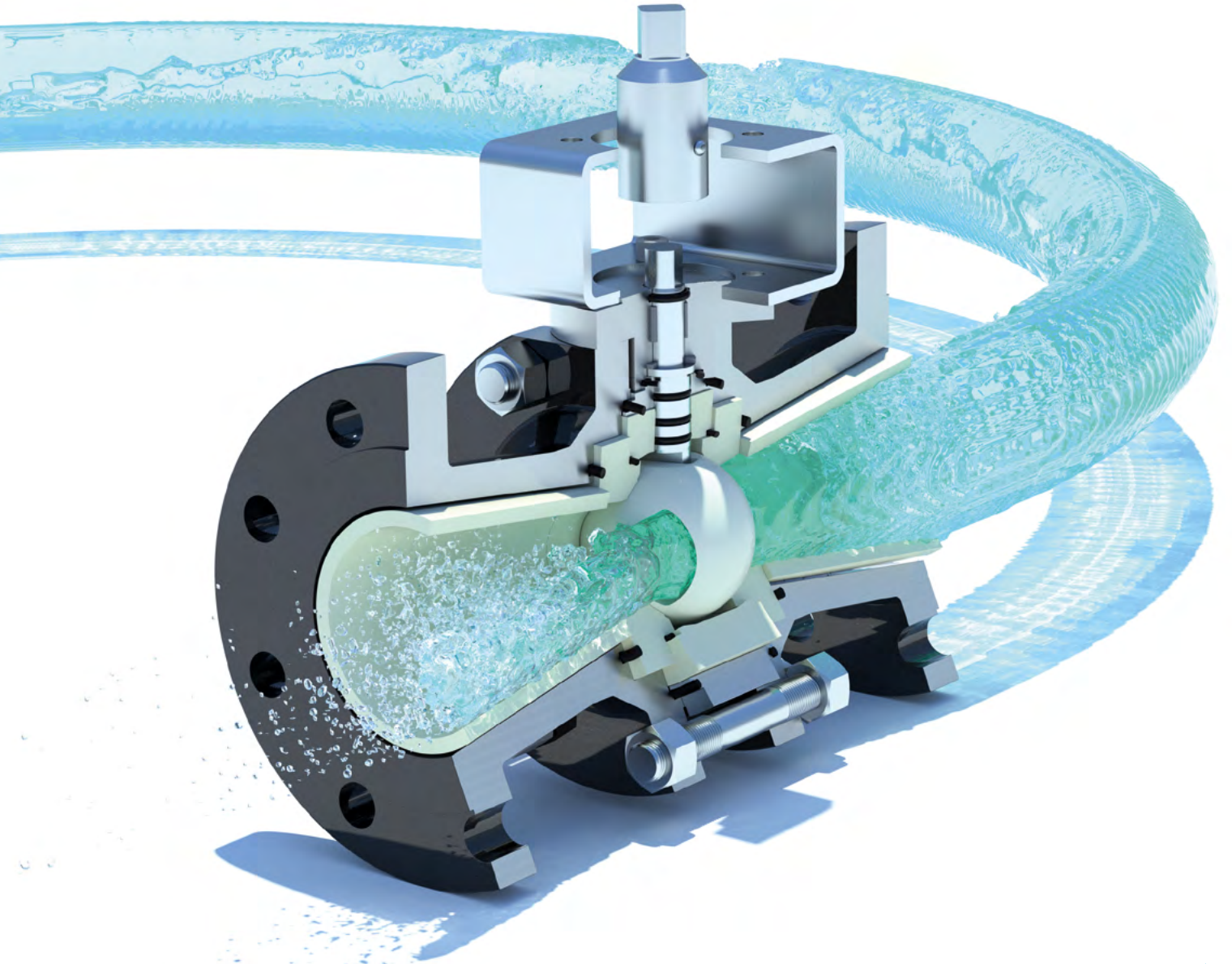

CERA VALVE®

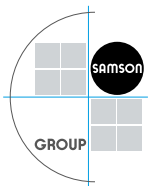

WEAR AND CORROSION RESISTANT BALL VALVES

System solutions with ceramic components



Wear protection in the toughest operating conditions

2

Conventional materials in valves can reach their limits in many industrial applications. Entirely new results often arise when high-performance ceramic materials are used. Ceramics can be used to an advantage everywhere wear and corrosion resistance and high temperature stability are needed.

Cera System has the most comprehensive range of tried and tested ceramic valve products available to our customers than does any other valve supplier worldwide. Many of our ceramic lined valves can be delivered in a relatively short lead time and are often the most cost effective valves for the most demanding applications.

As the technological market leader for ceramic lined industrial valves and pipeline components, we continually open up new areas of application together with our customers. Our range of services consists of the design engineering, testing, production and delivery of such systems. And, Cera System provides outstanding after sales customer service through factory trained application engineers and field service technicians. Our system solutions enable a great economic benefit in many applications.

Due to the fact that our products are used in almost all industrial sectors, our application engineers are aware of many different application problems and are usually already aware of a solution.

Our standard products are designed for use in extreme conditions. But we are also working closely with our customers to develop new solutions while relying on our vast knowledge and experience of applying engineered ceramics to critical service valves. In the valve sector, this includes:

- Valves with multiple protective housings
- Valves with blocking media
- Valves with heating and cooling jackets
- Valves manufactured from exotic material
- Multi-ported valves
- Sampling systems

Cera System valves are used and trusted by well know companies from all over the world. Reference can be supplied as requested.

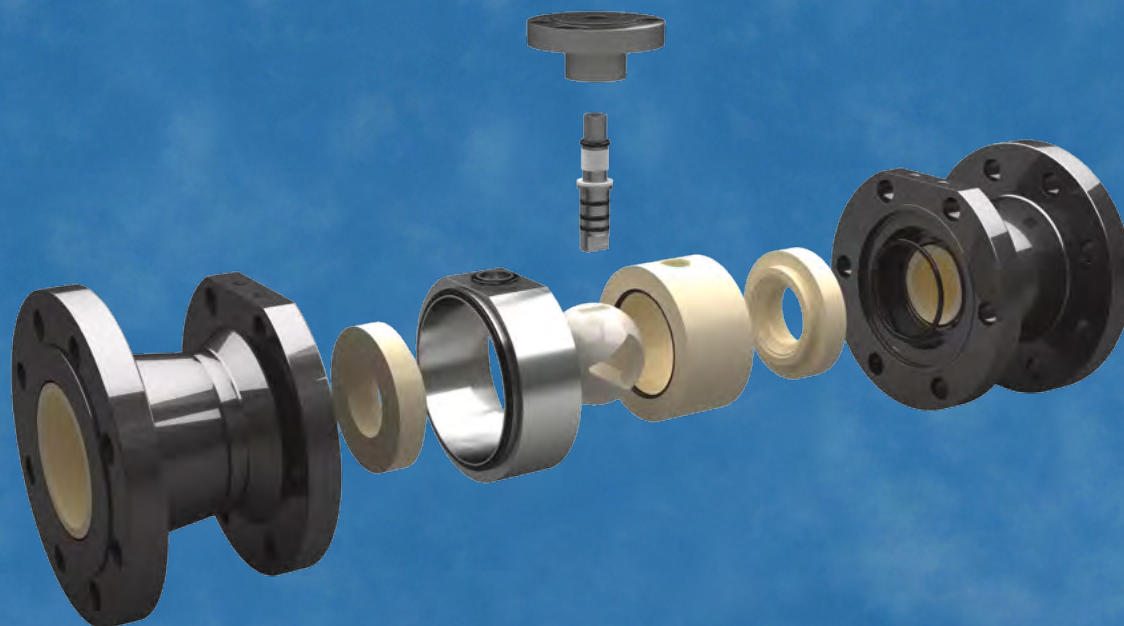

TYPICAL APPLICATIONS



3

COAL FIRED POWER PLANTS: Flue gas desulphurisation plants (FGD): Lime slurry and gypsum slurry process water with high chlorides and solids content

STEEL WORKS: Injection of coal powder (PCI); Injection of carbon powder in electric arc furnaces (EAF); Raw iron desulphurisation (supply of additives: CaC, MgO₂ ...)

POLYSILICON: Si₃Cl₄, TCS, raw silicon, splitting of silicon with acids, conveying of silicon powder ...

WASTE INCINERATION PLANTS: HCl-prewashers, limestone suspension for pH regeneration, corrosive washing water (HF loaded)

PAPER & PULP/dye works: Kaolin, bentonite, fillers, dyes, bleachers, talcum ...

Paper machine: Pulp residue, lime suspension, MgO₂, green liquor, wood particles in suspension ...

MINING: Copper: Splitting of ore with H₂SO₄, copper residues in suspension, concentrated copper slurries ("floatation") to the filter, pneumatic conveying of copper powder to smelter, air bleed valve on the pneumatic conveying container ...

There are similar applications for **zinc** and other **noble metals**.

PNEUMATIC CONVEYING: All types of dry bulk material (quartz, silicon, lime, coal, glass, cement, PP pellets ...)

PETROCHEMISTRY: FCC aluminium oxide powder as the catalyst, catalyst slurry ...

FERTILIZER: Ammonium nitrate slurry, phosphoric acid with solids (lime), dolomite, washing water with hydrofluoric acid content...

CHEMISTRY: PIGMENTS: TiO₂ suspension, Ti₃Cl₄, H₂SO₄ + TiO₂, FeCl₂ ...

BALL VALVE • SYSTEM OVERVIEW



KSV The CeraValve type KSV is a ceramic lined ball valve for On/Off function as well as for Throttling Control applications for corrosive media with abrasive solids content. It is an alternative to PTFE/PFA lined valves in the event that their performance limits (pressure, temperature, wear) are exceeded.

The upstream and downstream seats are fixed and the ball has a defined clearance. The ball is seated against the downstream seat by the differential pressure of the fluid through the valve.



KST The CeraValve type KST is a ceramic lined ball valve for the On/Off and Throttling Applications for highly abrasive and corrosive media. Valve bodies can be produced from various materials (e.g. stainless steel, Hastelloy, titanium, PVDF). Special configurations for low/high temperatures, TA-Luft low emission, and similar concerns can be supplied. High strength zirconia ceramics is used for the valve ball which seals against wear resistant alumina ceramic seats. The floating valve ball seals against the downstream seat by means of differential pressure.



KAT The CeraValve type KAT is a ceramic lined ball valve for the Open/Close function and the control tasks for excessive abrasive and corrosive media. It can be produced in all customary housing materials (e.g. stainless steel, Hastelloy, titanium, Monel). Furthermore, special requirements (low / high working temperatures, TA-Luft [German Clean Air Act] and similar matters) can be taken into consideration. The upstream seat is resilient. As a result, the ball has no clearance and always seals. Applications with low differential pressure and / or slow pressure build-up can be solved in this manner.

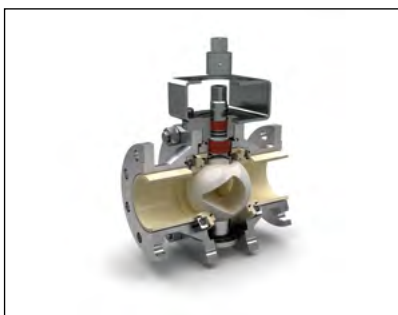

KZT The CeraValve type KZT is a ceramic lined ball valve for the Open/Close function and the control tasks for excessive abrasive and corrosive media. It can be produced in all customary housing materials (e.g. stainless steel, Hastelloy, titanium, Monel). Furthermore, special requirements (low / high working temperatures, TA-Luft [German Clean Air Act] and similar matters) can be taken into consideration. Higher pressure differentials are possible due to the trunnion mounted ball. The seats are cushioned. The valve can be pressurised from both sides.

Further versions with HT and TA-Luft modifications such as disarmed light modifications are possible in consultation with our sales engineers. We are happy to advise you.

TYPE CODING

X	X	X	-	X	X	-	X	X	TYPE
K									Ball valve
	S								Floating ball
	A								Spring loaded seat
	Z								Trunnion mounted ball
	G								Granule version
		V							Full wear protection
		T							Partial wear protection
		L							Without wear protection (light)
		C							Chemistry design
				H	T				High temperature
							T	A	TA-Luft
K	B	R							Particularly robust design



KGT The CeraValve type KGT is a ceramic lined ball valve for the Open / Close function and the control tasks for excessive abrasive and corrosive media. It can be produced in all customary housing materials (e.g. stainless steel, Hastelloy, titanium, Monel). Furthermore, special requirements (low / high working temperatures, TA-Luft and similar matters) can be taken into consideration. Higher pressure differentials are possible due to the trunnion mounted ball. The valve only seals on one side. A "dead space" is avoided as a result. Therefore, the ball valve is particularly suitable for pneumatic transport.

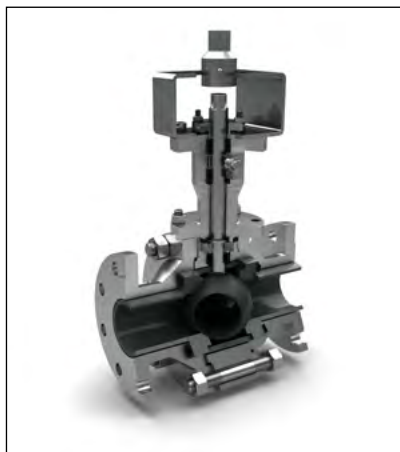

KST-HT The CeraValve type KST-HT is a ceramic lined ball valve for the Open / Close function and the control tasks for excessive abrasive and corrosive media in a temperature range of up to 550 °C / 1022 °F. It can be produced in all customary housing materials (e.g. stainless steel, Hastelloy, titanium). Special housing and ceramic materials permit special solutions of up to 950 °C / 1740 °F. The seats are rigid (fixed), The ball has a defined clearance, it is pressed against the downstream seat by the differential pressure, sealing it.



KBR The CeraValve type KBR is a wear resistant ball valve for the Open / Close function for abrasive and excessive abrasive media, preferred for applications when pneumatically transporting bulk materials. The sealing is carried out on a metallic basis. The seats can be optionally produced in ceramic.



BR 26 CERA The valve type BR 26 CERA is a stainless steel ball valve for on/off function with ceramic seats and ceramic ball for service in abrasive and corrosive applications. Especially for abrasive applications in chemical plants this valve can be beneficiary. The basic principle is based on the "floating ball" design. The seats are pushed by o-rings against the ball. This valve can be delivered with a manual handle, with pneumatic- or electric-actuator.

DESIGN:

Wear, corrosion and high-temperature resistant design
Three-part construction, therefore providing optimum adaptation to the operating conditions

NOMINAL SIZE RANGE:

Flange connections from DN15 up to DN 300 (1/2" up to 12")
Center Housing from DN15 up to DN 150 (1/2" up to 6")

PRESSURE RANGE:

PN 10 up to PN 63, ANSI class 150, class 300 and class 600
Other nominal pressure ranges on request

TEMPERATURE:

-25 to 950 °C / -13 to 1650 °F possible

BALL VALVE • KSV

MATERIALS / MATERIAL OPTIONS:

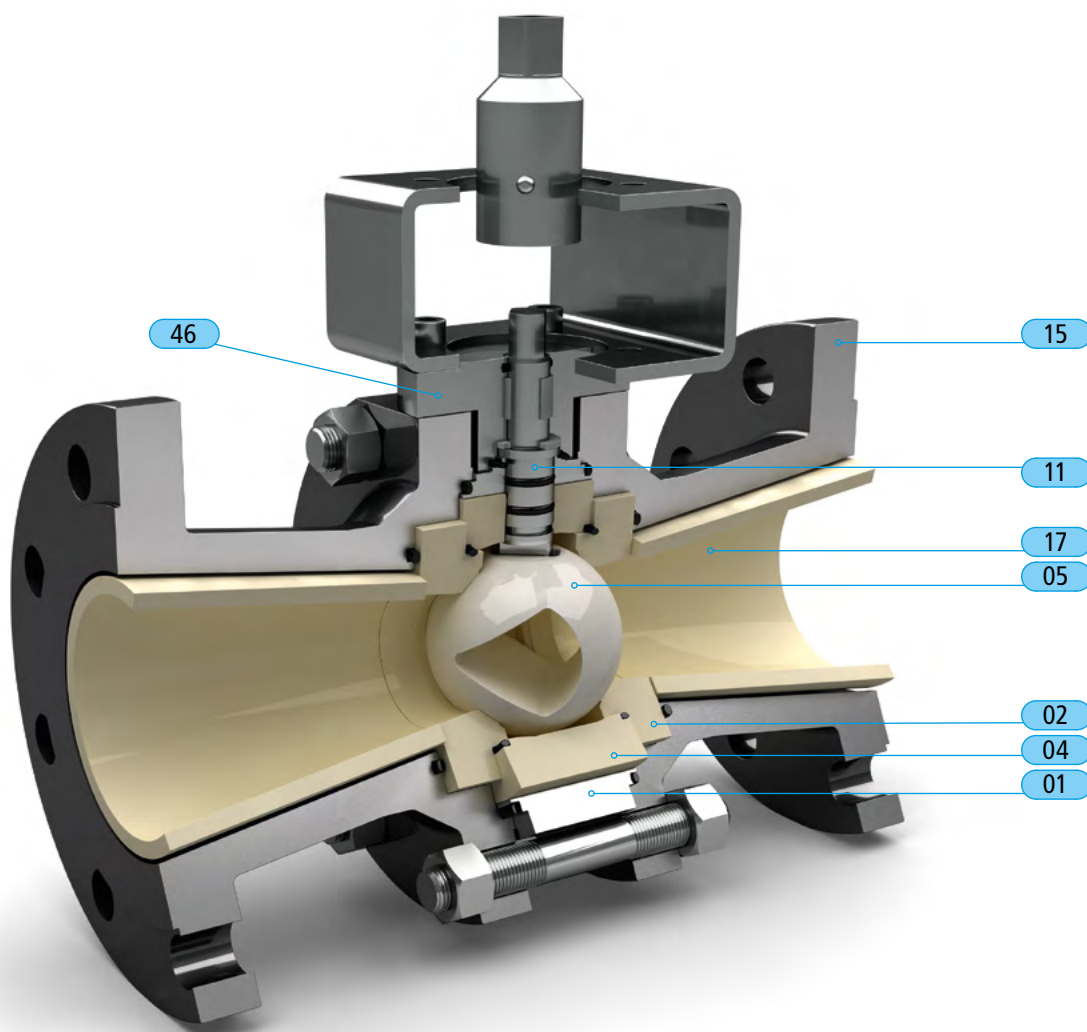

6

Item	Part description	Materials	Material options
01	Housing	1.4301	
02	Seat ring	Al ₂ O ₃	Si ₃ N ₄ - SSiC
04	Ball socket	Al ₂ O ₃	Si ₃ N ₄ - SSiC
05	Ball	ZrO ₂	Si ₃ N ₄ - WoC -2.4605
11	Shaft	2.4605	3.7035 - Tantal - ZrO ₂
15	Flange	P250GH Halar	
17	Wear protection sleeve	Al ₂ O ₃	Si ₃ N ₄ - SSiC
46	Bonnet flange	1.4301	
	O-rings	FKM(Viton)	FFKM (Kalrez)
	Seals	FKM(Viton)	PTFE
	Bearing bushes	PTFE	
	Screws / nuts	A2-/A4-70	

FUNCTION:

The CeraValve type KSV is a ceramic lined ball valve for the open / close function as well as for throttling control applications for use in excessively abrasive and corrosive applications.

The basic principle of this valve is based on a floating ball sealing against the downstream seat, using differential pressure as sealing force. Both seats are fixed while the ball has a predetermined "float space". The ceramic components of the valve are held within the metal housing which absorbs the physical load and vibration of the pipe system. The ¼-turn movement of the ball (0-90°) yields a specific valve opening. The ball slot is available in several different geometrical shapes depending on the desired flow characteristic for the application.

The three piece design of the valve allows for direct connection to existing pipelines without the need for pipe reducers in front and behind the valve. For example, the valve can be configured with 3.0" flanges with a 2.0" center body. The end flanges accommodate the direct mount to the 3.0" pipe while the reduced (2.0") center body provides for optimum selection of installed valve trim and also reduces weight and costs of the valve and installation.

Actuator connection is done by a yoke interface that meets the dimensional standards of ISO 5211. This provides for a direct center of most all ¼ turn actuation including, pneumatic, electric, and hydraulic actuators. 10 position locking manual hand levers and manual gear operators are also available. The yoke interface is removable and able to be easily modified to accommodate special applications.

NOMINAL SIZE RANGE:

Flange connections DN 15 (½") up to DN 300 (12")
Center housing: DN 15 (½") to DN 150 (6")

PRESSURE RANGE:

PN 10 to PN 40
ANSI class 150 and class 300
Other nominal pressure ranges on request

OVERALL LENGTH:

according to EN 558-1 Series 1+27
according to ASME / ANSI B 16.10 / EN 558-2 Series 37+38

OPTIONS:

TA-Luft low emission design
Wafer-type
optional ceramics, stem shafts and
Sealing materials
Chemistry design (KSC type)

TEMPERATURE RANGE:

-30 °C to +160 °C / -22 °F to +320 °F

TYPICAL APPLICATION AREAS:

Coal fired power plants: FGD

- Limestone Slurry
- Hydrated Lime Slurry
- Gypsum Slurry
- High Chlorides Water
- Ash

Waste incineration plants:

- Dosing of HCl washing water (prewasher)
- Dosing of the lime milk for the absorber (pH regulation, desulphurisation)

Dye production:

- Dosing of TiO₂ suspension with sulphuric acid
- Diluted acid preparation

Mining:

- Dosing of copper suspension with acid content

Chemistry:

- Alternatives to PTFE / PFA lined valves when the media is abrasive
- Alternatives to valve manufactured from special materials (e.g. Hastelloy, titanium, etc.).

BALL VALVE • KST

MATERIALS / MATERIAL OPTIONS:

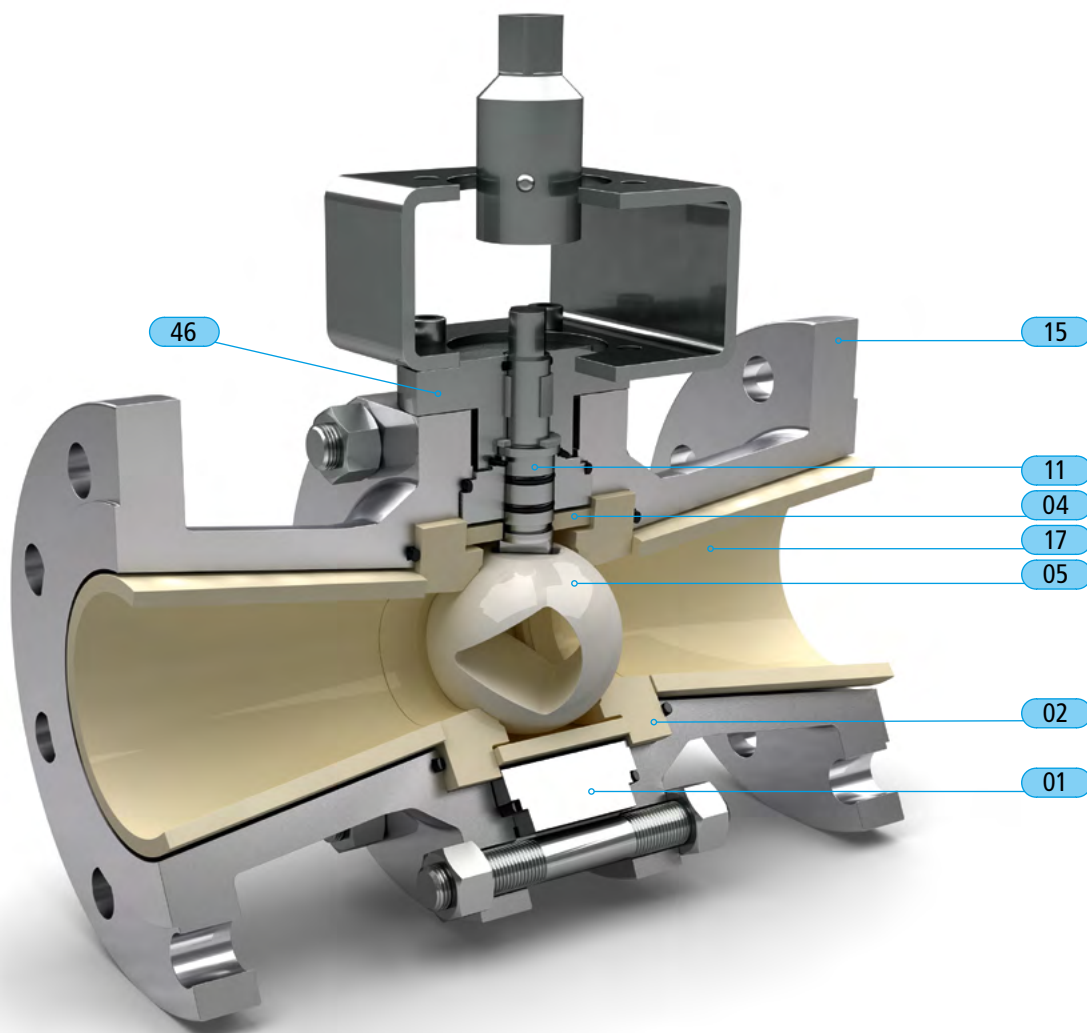

Item	Part description	Materials	Material options
01	Housing	1.4301	1.4462 - 1.4571 - 1.4539 - P250GH - PVDF - PP - 3.7035
02	Seat ring	Al ₂ O ₃	Si ₃ N ₄ - SiC
04	Ball socket	Al ₂ O ₃	Si ₃ N ₄ - SiC
05	Ball	ZrO ₂	Si ₃ N ₄ - WoC - 2.4605 - 1.4112
11	Shaft	1.4462	3.7035 - Tantal - ZrO ₂ - 2.4605
15	Flange	1.4301	1.4462 - 1.4571 - 1.4539 - P250GH - PVDF - PP - 3.7035
17	Wear protection sleeve	Al ₂ O ₃	Si ₃ N ₄ - SiC
46	Bonnet flange	1.4301	1.4462 - 1.4571 - 1.4539 - P250GH - 3.7035
	O-rings	FKM(Viton)	FFKM (Kalrez)
	Seals	FKM(Viton)	PTFE - Viton/FEP - graphite
	Bearing bushes	PTFE	
	Screws / nuts	A2-/A4-70	

FUNCTION:

The CeraValve type KST is a ball valve with ceramic lining for open/close function and control tasks to be used in excessively abrasive and corrosive media. It is to be preferably used if special requirements are placed on the stem sealing, on the housing materials (PVDF, titanium) or if there are very high or very low operating temperatures and high pressures.

The basic principle is based on the floating ball design. The seats are rigid (fixed), the ball has a defined clearance and is pressed against the downstream seat by the differential pressure, sealing it. The ¼-turn movement of the ball between 0 and 90° releases an accurately defined opening cross-section. The geometric shape of the ball defines the function and control characteristics.

This ball valve has a "three part body" design. Consequently, it can be adapted to existing pipelines and the flow and control characteristics can be optimised.

These valves are available with manual lever or gear box, as well as with pneumatic, electric and hydraulic actuators. The actuator is mounted by means of a yoke and adapter arrangement. All customary actuators can be used as part-turn valve actuators.

Special connections are possible.

NOMINAL SIZE RANGE:

Flange connections DN 15 (½") up to DN 300 (12")
Center housing: DN 15 (½") to DN 150 (6")

PRESSURE RANGE:

PN 10 to PN 63
ANSI class 150, class 300, and class 600
Other nominal pressure ranges on request

OVERALL LENGTH:

according to EN 558-1 Series 1+27
According to ASME / ANSI B16.10 / EN 558-2 Series 37+38

OPTIONS:

all metallic materials for the housing
Plastic housing (e.g. PP or PVDF)
Fire-safe design
TA-Luft design
High temperature design (KST-HT type)
Wafer-type
Chemistry design (KSC type)

TEMPERATURE RANGE:

Standard: -30 °C to +180 °C / -22 °F to +356 °F
Up to 310 °C / 590 °F possible with Kalrez + graphite

TYPICAL APPLICATION AREAS:

Steel works:

- Control valve for coal injection (PCI)
- Expansion valve for coal silo
- Dosing of additive in
Electric arc furnace (EAF): e.g. carbon powder
- Raw iron desulphurisation with CaC, SiO₂, MgO₂ ...
- Slag formation with quartz sand

Paper & pulp:

- Control valve for lime slurry
- Control valve for Kaolin, talcum, pulp with wood residue ...

Chemistry: (with PVDF housing)

- Solid-containing media with a low pH value

Abbreviations:

PCI: Pulverised Coal Injection

EAF: Electric Arc Furnace

BALL VALVE • KAT

MATERIALS / MATERIAL OPTIONS:

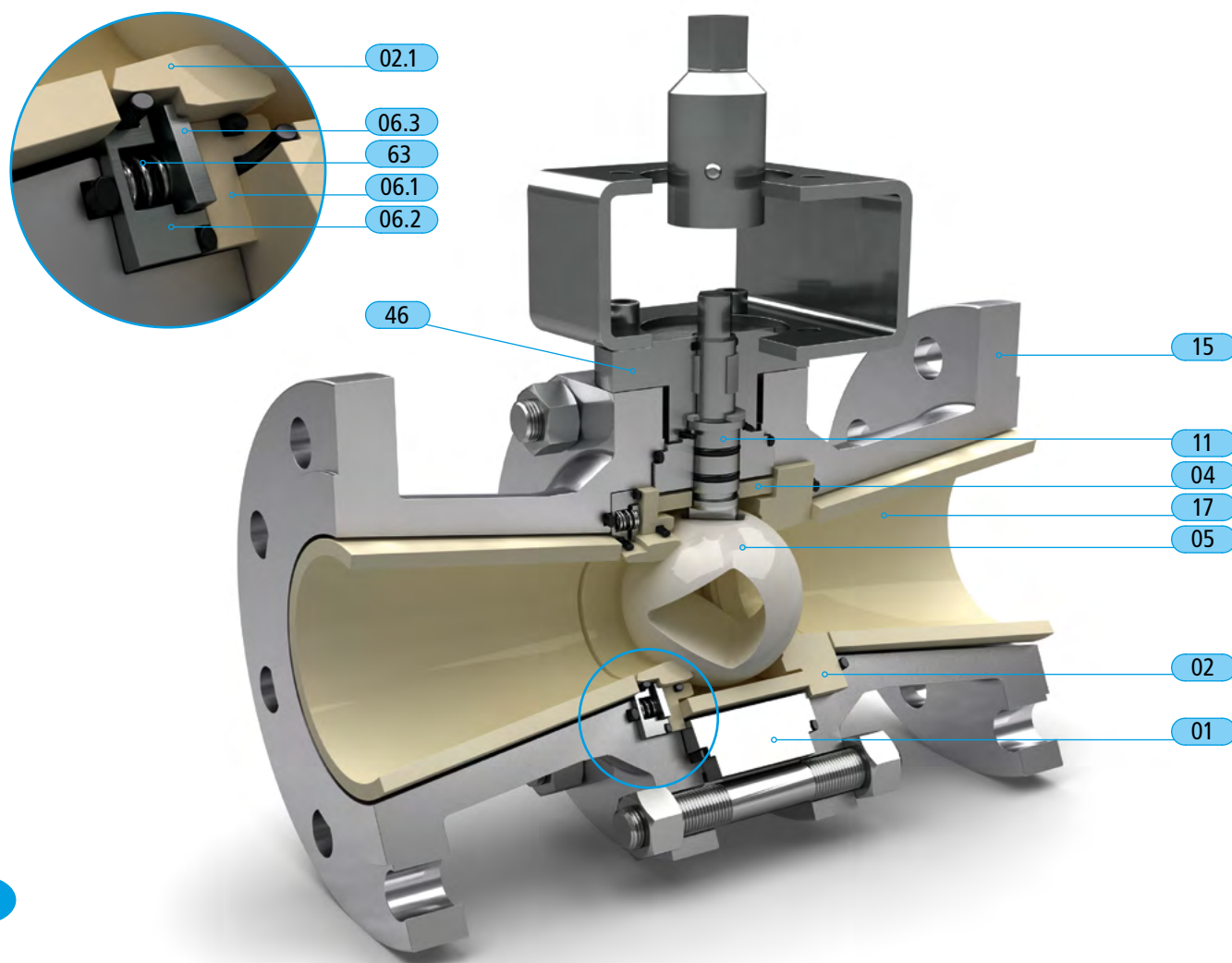

10

Item	Part description	Materials	Material options
01	Housing	1.4301	1.4462 - 1.4571 - 1.4539 -P250GH - PVDF -PP - 3.7035
02	Seat ring	Al ₂ O ₃	Si ₃ N ₄ - SSiC - ZrO ₂
02.1	Spring loaded seat ring	Al ₂ O ₃	Si ₃ N ₄ - SSiC
04	Center sleeve	Al ₂ O ₃	Si ₃ N ₄ - SSiC
05	Ball	ZrO ₂	Si ₃ N ₄ - WoC -2.4605 - 1.4112
06.1	Holding ring	Al ₂ O ₃	1.4301
06.2	Pressure ring spring	1.4301	1.4462
06.3	Pressure ring seat	1.4301	1.4462
11	Shaft	1.4462	3.7035 - Tantal - ZrO ₂ - 2.4605
15	Flange	1.4301	1.4462 - 1.4571 - 1.4539 -P250GH - PVDF -PP - 3.7035
17	Wear protection sleeve	Al ₂ O ₃	Si ₃ N ₄ - SSiC
46	Bonnet flange	1.4301	1.4462 - 1.4571 - 1.4539 -P250GH - 3.7035
63	Pressure spring	1.4310	
	O-rings	FKM(Viton)	FFKM (Kalrez)
	Seals	FKM(Viton)	PTFE - Viton/FEP - graphite
	Bearing bushes	PTFE	
	Screws / nuts	A2-/A4-70	

FUNCTION:

The CeraValve type KAT is a ball valve with ceramic lining for open/close function and control tasks to be used in excessively abrasive media. It is to be preferably used if special requirements are placed on the shaft sealing, on the housing materials (PVDF, titanium) or if there are very high or very low operating temperatures and high pressures. The valve is based on the floating ball principle. The outlet seat ring is fixed. The inlet seat ring is spring loaded. As a result, the ball has no clearance and always seals.

The ¼-turn movement of the ball between 0 and 90° releases an accurately defined opening cross-section.

The geometric shape of the ball defines the function and control characteristics.

This ball valve has a "three part body" design.

Consequently, it can be adapted to existing pipelines and the flow and control characteristics can be optimised.

These valves are available with manual lever or gear box, as well as with pneumatic, electric and hydraulic actuators. The actuator is mounted by means of a yoke and adapter arrangement. All customary actuators can be used as part-turn valve actuators. Special connections are possible.

NOMINAL SIZE RANGE:

Flange connections DN 15 (½") up to DN 300 (12")
Center housing: DN 15 (½") to DN 150 (6")

PRESSURE RANGE:

PN 10 to PN 63
ANSI class 150, class 300, and class 600
Other nominal pressure ranges on request

OVERALL LENGTH:

according to EN 558-1 Series 1+27
according to ASME / ANSI B16.10 / EN 558-2 Series 37+38

OPTIONS:

all metallic materials for the housing
Fire-safe design
TA-Luft design
High temperature design (KAT-HT type)
Wafer-type
Chemistry design (KAC type)

TEMPERATURE RANGE:

Standard: -30 °C to +180 °C / -22 °F to +356 °F
Up to 310 °C / 590 °F possible with Kalrez + graphite

TYPICAL APPLICATION AREAS:

Steel works:

- Silo expansion valve with low seat leakage (ANSI class V)
- Pneumatic conveying of carbon powder, quartz, carbide ...

Silicon:

- Conveying of silicon powder
- Silicon conveyor silo expansion valve

Petrochemistry:

- Dosing of FCC cat cracker (Al₂O₃ powder)

Mining:

- Dosing and conveying of copper concentrate
- Copper conveying silo expansion valve

BALL VALVE • KZT

MATERIALS / MATERIAL OPTIONS:

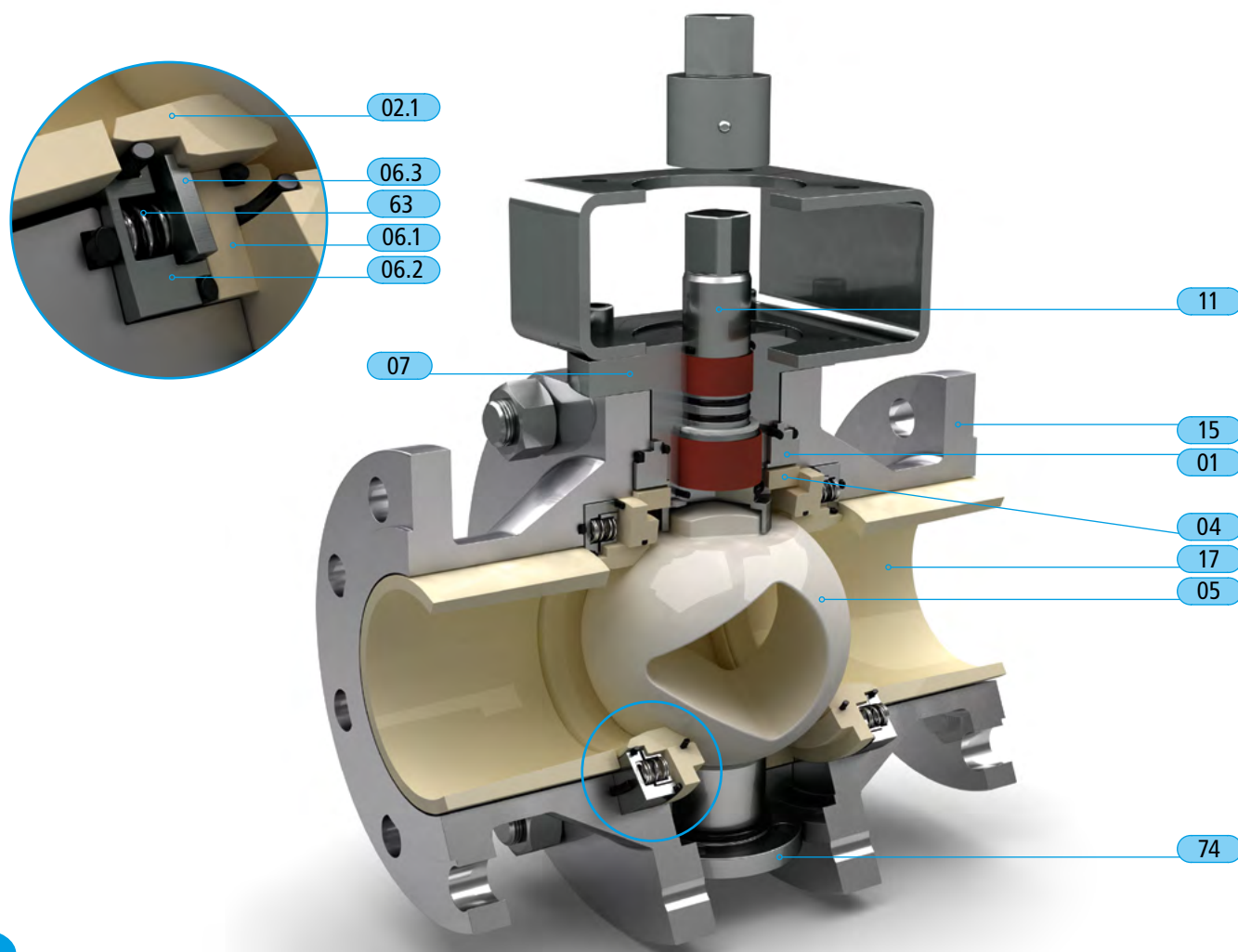

12

Item	Part description	Materials	Material options
01	Housing	1.4301	1.4462 - 1.4571 - 1.4539 - P250GH - 3.7035
02.1	Spring loaded seat ring	Al ₂ O ₃	Si ₃ N ₄ - SSiC - ZrO ₂
04	Center sleeve	Al ₂ O ₃	Si ₃ N ₄ - SSiC
05	Ball	ZrO ₂	Si ₃ N ₄ - WoC -2.4605 - 1.4112
06.1	Holding ring	Al ₂ O ₃	1.4301
06.2	Pressure ring spring	1.4301	1.4462
06.3	Pressure ring seat	1.4301	1.4462
07	Packing housing	1.4301	1.4462 - 1.4571 - 1.4539 -P250GH - 3.7035
11	Shaft	1.4462	3.7035 - Tantal
15	Flange	1.4301	1.4462 - 1.4571 - 1.4539 -P250GH - 3.7035
17	Wear protection sleeve	Al ₂ O ₃	Si ₃ N ₄ - SSiC
63	Pressure spring	1.4310	
74	Counter bearing trunnion	1.4301	1.4462 - 1.4571 - 1.4539 -P250GH - 3.7035
	O-rings	FKM(Viton)	FFKM (Kalrez) - Viton/FEP
	Seals	FKM(Viton)	PTFE - Graphite
	Bearing bushes	PTFE	Stellite
	Screws / nuts	A2-/A4-70	

FUNCTION:

The CeraValve type KZT is a ball valve with ceramic lining for open/close function and control tasks to be used in excessively abrasive and corrosive media. It is to be preferably used if special requirements are placed on the stem sealing, on the housing materials (titanium) or if there are very high or very low operating temperatures and high pressures. The valve can be pressurised from both sides. The function is based on a trunnion mounted ball. The seats are spring-loaded. The upstream seat primarily seals.

The ¼-turn movement of the ball between 0 and 90° releases an accurately defined opening cross-section.

The geometric shape of the ball defines the function and control characteristics.

This ball valve has a "three part body" design. Consequently, it can be adapted to existing pipelines and the flow and control characteristics can be optimised.

These valves are available with manual lever or gear box, as well as with pneumatic, electric and hydraulic actuators. The actuator is mounted by means of a yoke and adapter arrangement. All customary actuators can be used as part-turn valve actuators. Special connections are possible.

NOMINAL SIZE RANGE:

Flange connections DN 65 (2 ½") up to DN 300 (12")
Center housing: DN 65 (2 ½") to DN 150 (6")

PRESSURE RANGE:

PN 10 to PN 63
ANSI class 150, class 300, and class 600
Other nominal pressure ranges on request

OVERALL LENGTH:

according to EN 558-1 Series 1+27
according to ASME / ANSI B16.10 / EN 558-2 Series 37+38

OPTIONS:

all metallic materials for the housing
Fire-safe design
TA-Luft design
High / low temperature design
Wafer-type

TEMPERATURE RANGE:

Standard: -30 °C to +180 °C / -22 °F to +356 °F
Up to 310 °C / 590 °F possible with Kalrez + graphite

TYPICAL APPLICATION AREAS:

Similar applications to KGT,
with pressure load on both sides however.

Petrochemistry:

- Catalyst container valve

Pneumatic conveying:

- at higher operating pressures (trunnion mounted balls)
- suitable for: Silicon, lime, coal, cement, glass ...

Mining:

- Ore conveying, ore dosing, copper concentrate ...

BALL VALVE • KGT

MATERIALS / MATERIAL OPTIONS:

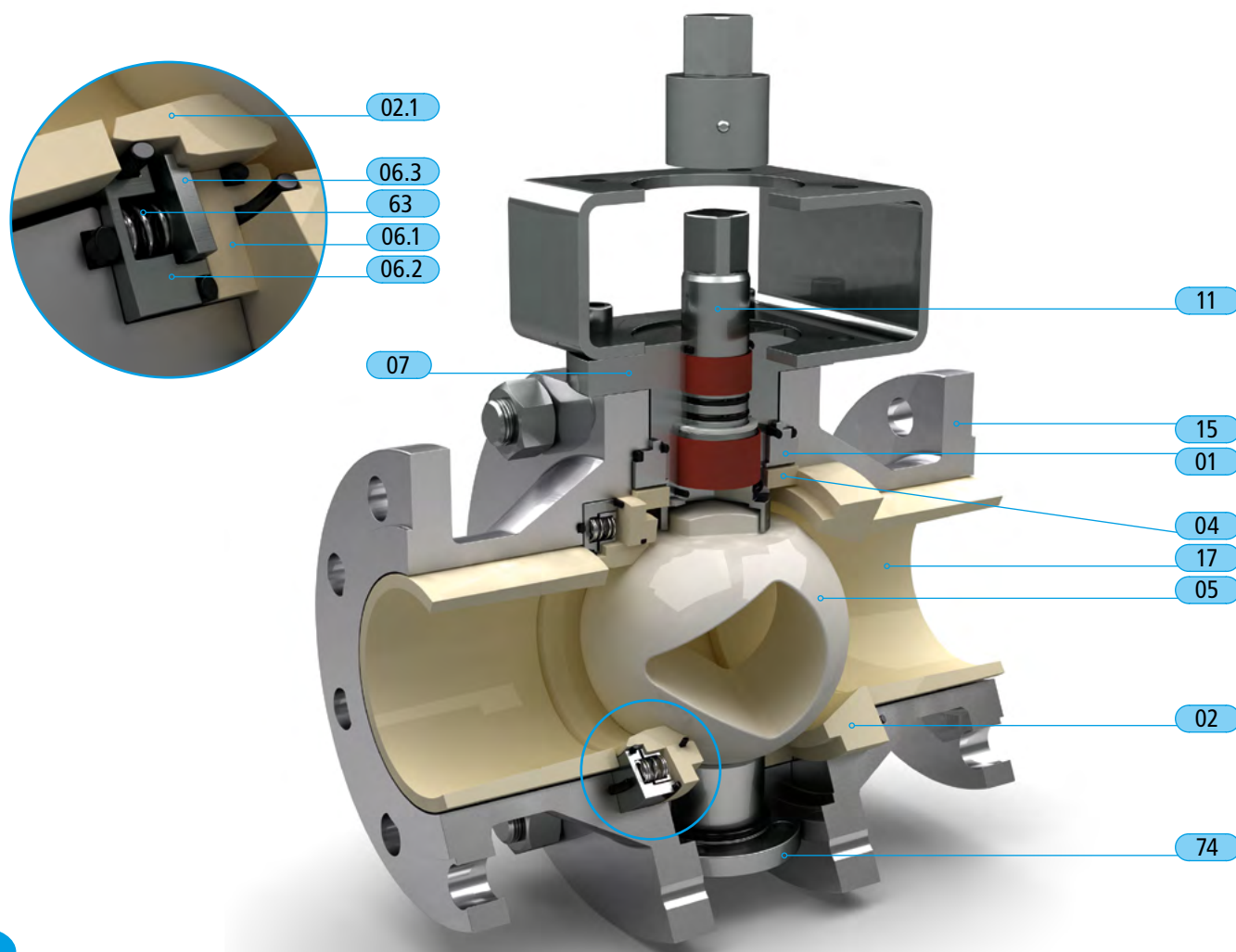

14

Item	Part description	Materials	Material options
01	Housing	1.4301	1.4462 - 1.4571 - 1.4539 - P250GH - 3.7035
02	Cone sleeve	Al ₂ O ₃	Si ₃ N ₄ - SSiC - ZrO ₂
02.1	Spring loaded seat ring	Al ₂ O ₃	Si ₃ N ₄ - SSiC - ZrO ₂
04	Center sleeve	Al ₂ O ₃	Si ₃ N ₄ - SSiC
05	Ball	ZrO ₂	Si ₃ N ₄ - WoC -2.4605 - 1.4112
06.1	Holding ring	Al ₂ O ₃	1.4301
06.2	Pressure ring spring	1.4301	1.4462
06.3	Pressure ring seat	1.4301	1.4462
07	Packing housing	1.4301	1.4462 - 1.4571 - 1.4539 - P250GH - 3.7035
11	Shaft	1.4462	3.7035 - Tantal
15	Flange	1.4301	1.4462 - 1.4571 - 1.4539 - P250GH - 3.7035
17	Wear protection sleeve	Al ₂ O ₃	Si ₃ N ₄ - SSiC
63	Pressure spring	1.4310	
74	Counter bearing trunnion	1.4301	1.4462 - 1.4571 - 1.4539 - P250GH - 3.7035
	O-rings	FKM(Viton)	FFKM (Kalrez) - Viton/FEP
	Seals	FKM(Viton)	PTFE - Graphite
	Bearing bushes	PTFE	Stellite
	Screws / nuts	A2-/A4-70	

FUNCTION:

The CeraValve type KGT is a ball valve with ceramic lining for open/close function and control tasks to be used in excessively abrasive media. It is to be preferably used for solid particles outfeed if special requirements are placed on the stem sealing, on the housing materials (titanium) or if there are very high or very low operating temperatures and high pressures.

On the outlet side, the ball valve has a cone sleeve instead of a seat ring. The pressurisation should take place in the direction of flow-through.

The function is based on a trunnion mounted ball. The seat ring is resilient.

The round geometrical shape of the ball bore is standard.

This ball valve has a "three part body" design. Consequently, it can be adapted to existing pipelines and the flow and control characteristics can be optimised.

These valves are available with manual lever or gear box, as well as with pneumatic, electric and hydraulic actuators. The actuator is mounted by means of a yoke and adapter arrangement. All customary actuators can be used as part-turn valve actuators. Special connections are possible.

NOMINAL SIZE RANGE:

Flange connections DN 65 (2 1/2") up to DN 300 (12")
Center housing: DN 65 (2 1/2") to DN 150 (6")

PRESSURE RANGE:

PN 10 to PN 63
ANSI class 150, class 300, and class 600
Other nominal pressure ranges on request

OVERALL LENGTH:

according to EN 558-1 Series 1+27
according to ASME / ANSI B16.10 / EN 558-2 Series 37+38

OPTIONS:

all metallic materials for the housing
Fire-safe design
TA-Luft design
High / low temperature design
Wafer-type

TEMPERATURE RANGE:

Standard: -30 °C to +180 °C / -22 °F to +356 °F
Up to 310 °C / 590 °F possible with Kalrez + graphite

TYPICAL APPLICATION AREAS:

Steel works:

- Silo expansion valve with low seat leakage (ANSI class V)
- Pneumatic conveying of carbon powder, quartz, carbide ...

Silicon:

- Conveying of silicon powder
- Silicon conveyor silo expansion valve

Petrochemistry:

- Dosing of FCC cat cracker (Al₂O₃ powder)

Mining:

- Dosing and conveying of copper concentrate
- Copper conveying silo expansion valve

BALL VALVE • KST-HT

MATERIALS / MATERIAL OPTIONS:

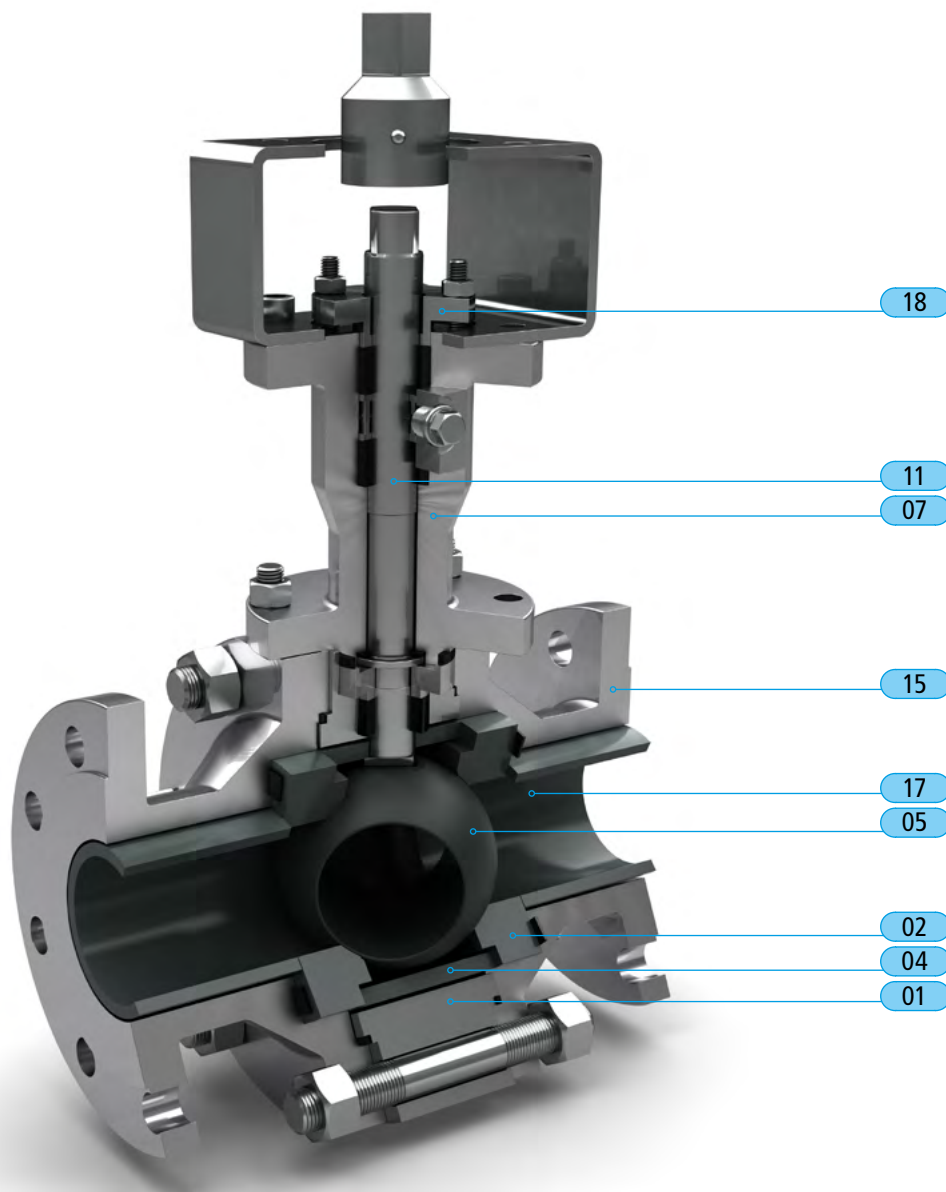

16

Item	Part description	Materials	Material options
01	Housing	1.4301	1.4876(H) - 1.4462 - 1.4571 - 1.4539 - P250GH
02	Seat ring	SSiC	Si ₃ N ₄
04	Center sleeve	SSiC	Si ₃ N ₄
05	Ball	Si ₃ N ₄	ZrO ₂ - 1.4112
07	Packing housing	1.4301	1.4876(H) - 1.4462 - 1.4571 - 1.4539 - P250GH
11	Shaft	1.4542	1.4876 - 1.4462
15	Flange	1.4301	1.4876(H) - 1.4462 - 1.4571 - 1.4539 - P250GH
17	Wear protection sleeve	SSiC	Si ₃ N ₄
18	Stuffing box gland	1.4301	1.4462 - 1.4571 - 1.4539 - P250GH
	Packages	Graphite	Stuffing box packaging
	Seals	Graphite	
	Bearing bushes	Stellite / Graphite	
	Screws / nuts	A2-/A4-70	21CrMoV57 / 24CrMo5 - 1.4876/1.4910

FUNCTION:

The CeraValve type KST-HT is a ceramic lined ball valve for the open / close function and the control tasks for use in excessive abrasive and corrosive media at temperatures above 300 °C / 570 °F.

Special housing and ceramic materials permit solutions of up to 950 °C / 1740 °F.

The basic principle is based on the floating ball design. The seats are rigid (fixed), The ball has a defined clearance and is pressed against the downstream seat by the differential pressure, sealing it. The ¼-turn movement of the ball between 0 and 90 ° releases an accurately defined opening cross-section.

The geometric shape of the ball defines the function and control characteristics.

This ball valve has a "three part body" design. Consequently, it can be adapted to existing pipelines and the flow and control characteristics can be optimised.

These valves are available with manual lever or gear box, as well as with pneumatic, electric and hydraulic actuators. The actuator is mounted by means of a yoke and adapter arrangement. All customary actuators can be used as part-turn valve actuators. Special connections are possible.

NOMINAL SIZE RANGE:

Flange connections DN 15 (½") up to DN 300 (12")
Center housing: DN 15 (½") to DN 150 (6")

PRESSURE RANGE:

PN 10 to PN 63
ANSI class 150, class 300, and class 600
Other nominal pressure ranges on request

OVERALL LENGTH:

according to EN 558-1 Series 1+27
according to ASME / ANSI B16.10 / EN 558-2 Series 37+38

OPTIONS:

all metallic materials for the housing
(e.g. 1.4876H)
Special ceramics that are suitable for high temperatures and thermal shock
Fire-safe design
TA-Luft design
Wafer-type

TEMPERATURE RANGE:

HT design: max. 450 °C / 842 °F
X-HT design: max. 950 °C / 1740 °F

TYPICAL APPLICATION AREAS:

Steel works:

- Ore direct reduction (DRI), ore-air mixture at 750 °C / 1380 °F

Dye production:

- Cl₂-Gas with Ti₃Cl₄ at 800 °C / 1470 °F with Ti slurry and coke

Polysilicon:

- Control of trichlorosilane (TCS) at 500 °C / 932 °F
- Conveying of Si₃Cl₄ at 400 °C / 752 °F

Petrochemistry:

- Catalyst "cracking" process 750 °C / 1380 °F
- Recycling of FCC catalyst 400-600 °C / 752-1110 °F

Energy:

- Biomass to combustible gas (pyrolysis) 600-800 °C / 1110-1470 °F

BALL VALVE • KBR

MATERIALS / MATERIAL OPTIONS:

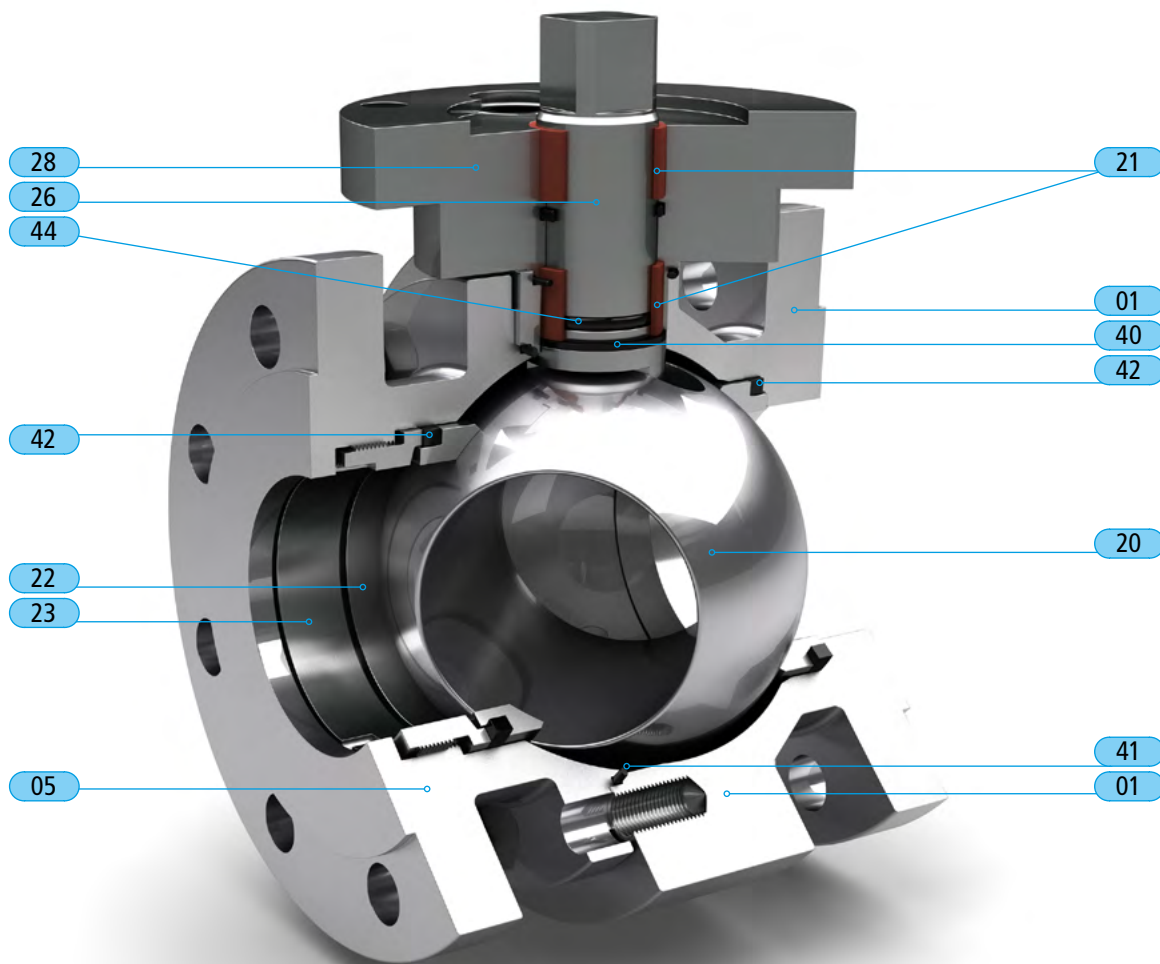

Item	Part description	Materials	Material options
01	Housing	1.4301	1.4571 - P250GH
05	Flange	1.4301	1.4571 - P250GH
20	Ball	30EH	
21	Bearing bushes	DU	
22	Seat ring	1.4462/KVT433	Al ₂ O ₃
23	Screwed ring	1.4301	1.4571 - P250GH
26	Shaft	1.4301	1.4462
28	Bonnet flange	1.4301	1.4571 - P250GH
40	Slide plate	Graphite	
41	Housing seal	Viton	Graphite
42	Spring element	Graphite	
43	Cover flange seal	Viton	Graphite
44	CW seal	Viton	FFKM(Kalrez)- Graphite
	Housing screws	A2-70	
	Cover flange screws	A2-70	

FUNCTION:

The CeraValve type KBR is a particularly robust, metallic ball valve for the open/close function for abrasive and excessive abrasive media, preferred for applications when pneumatically transporting bulk materials. Both the shaft as well as the shaft insert and the seats are designed in a particularly stable manner.

The valve can be pressurised from both sides. The functional principle is based upon the floating ball (trunnion mounted ball as of DN 150/6"). The seat rings are pressed against the ball by means of spring elements. The round geometrical shape of the ball bore is standard.

This ball valve has a "two part body" design.

These valves are available with manual lever or gear box, as well as with pneumatic, electric and hydraulic actuators.

All customary actuators can be used as ¼-turn valve actuators. Special connections are possible.

NOMINAL SIZE RANGE:

DN 25 (1") to DN 300 (12")

PRESSURE RANGE:

PN 10 to PN 40

ANSI class 150 and class 300

Other nominal pressure ranges on request

OVERALL LENGTH:

DIN overall lengths according to EN 558-1 Series 27

ANSI class 150 overall lengths according to

EN 558-2 Series 3 (up to 4") and Series 12 (from 5")

ANSI class 300 overall lengths according to

EN 558-2 Series 4

OPTIONS:

Diverse metallic materials

Wear protection bushing in the outlet

Seats manufactured from ceramic

TEMPERATURE RANGE:

Standard: -30 °C to +180 °C / -22 °F to +356 °F

Up to 310 °C / 590 °F possible with Kalrez and graphite

TYPICAL APPLICATION AREAS:

Pneumatic conveying:

- Bulk material silo, silo drain valve,
Conveying valve for media such as: Fly ash, cement, glass, sand, plaster, ore ...

Power plants:

- Fly ash, plaster, lime ...

Steel works:

- Ore, coal, coke ...

BALL VALVE BR 26 CERA

MATERIALS / MATERIAL OPTIONS:

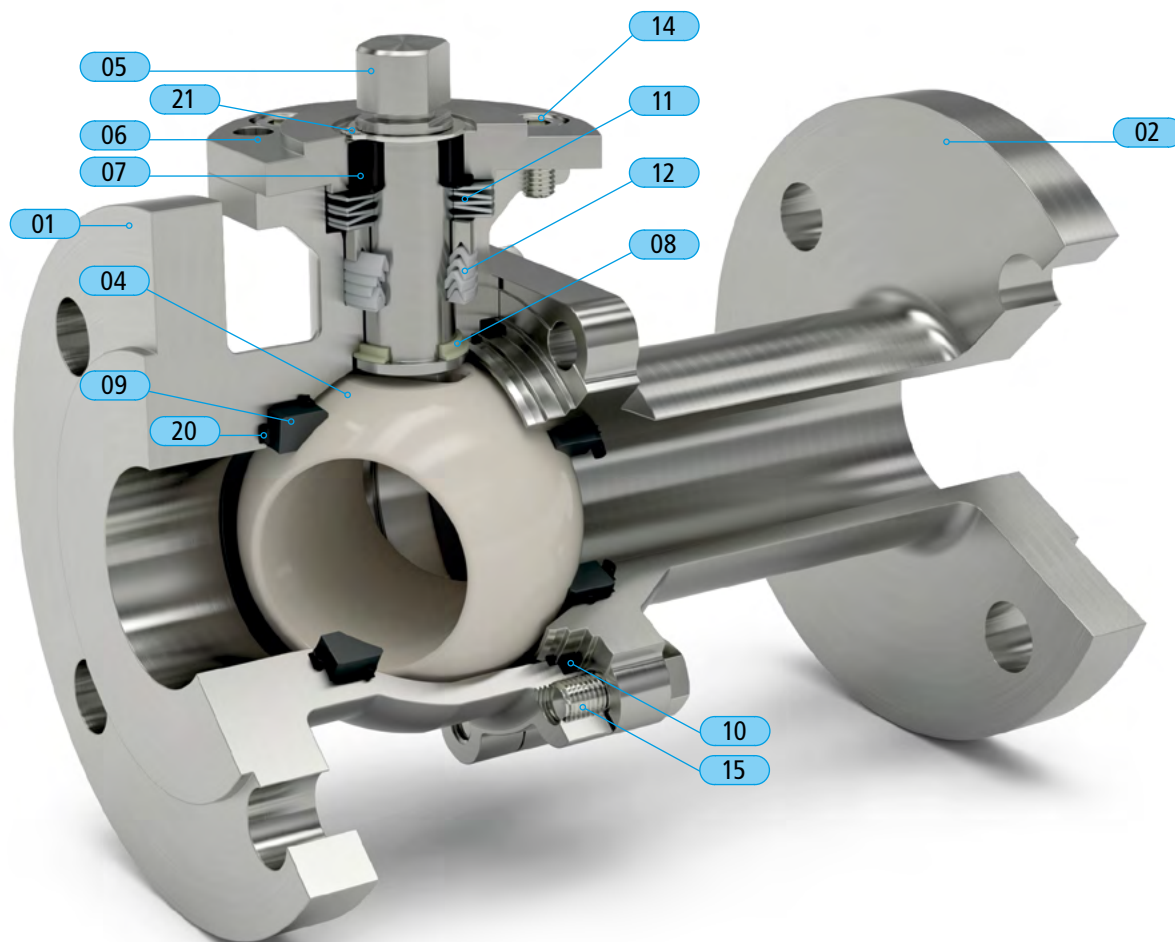

20

ITEM	Part description	Material	
01	Main body	1.4408 / ASTM A351 CF8M	Flange Design
02	Side body	1.4408 / ASTM A351 CF8M	Flange Design
04	Ball	ZrO ₂ -ceramic	
05	Shaft	1.4462 / ASTM 2205	
06	Packing flange	1.4301 / AISI 304	
07	Bearing bushing	PTFE-carbon (25%)	
08	Bearing bushing	PTFE-glass (25%)	
09	Seat ring	SiSiC-ceramic	
10	Body gasket	PTFE	
11	Set of spring washers	Stainless spring steel	
12	V-ring packing	PTFE	
14	Bonnet screw	AISI 31	
15	Body screw	AISI 316	
20	O-rings	FKM	
21	Stem safety ring	Stainless spring steel	

FUNCTION:

The valve type BR 26 CERA is a stainless steel ball valve for on/off function with ceramic seats and ceramic ball for service in abrasive and corrosive applications. Especially for abrasive applications in chemical plants this valve can be beneficiary.

The basic principle is based on the "floating ball" design. The seats are pushed by o-rings against the ball. This valve can be delivered with a manual handle, with pneumatic- or electric –actuator.

DESIGN:

Floating ball

Shaft sealing acc. to "TA-Luft" (zero emission)

Blow-out proof shaft

Shaft with torsion-control

NOMINAL SIZE RANGE:

DIN DN15 – DN100

ANSI 1/2" – 4"

RATINGS:

DIN PN 10 – PN 40

ANSI Class 150 (Class 300 upon demand)

TEMPERATURE RANGE:

-10 °C – +200 °C / +14 – +392 °F

FACE-FACE DIMENSIONS:

DIN Length acc. to EN558-1, Row 1 and 27.

ANSI Length acc. to EN558-1, Row 3

TYPICAL APPLICATION AREAS:

- Corrosive fluids with solids in suspension
- Steam with condensation
- Pneumatic transport of solids (bulk)
- Sulfuric Acids (>96%) with ore-residues or other particles
- Biomass preparation
- Pulp & paper

FUNCTION:

The strict regulations of the current TA-Luft place the highest of demands on the shaft seals of valves, especially with regard to fugitive emissions. The TA-Luft sealing kits cover the majority of applications, especially in the chemical and petrochemical sector and are suitable for use in new valves or to retrofit existing valves.

Available TA-Luft sealing kits:

BuraTAL® T3 9650/T3

Application limits

Temperature:	-10 °C to +250 °C / +14 °F to +482 °F
Pressure:	63 bar / 914 psi
Chemical resistance:	pH value 1-13

BuraTAL® T3 9650/T1

Application limits

Temperature:	-40 °C to +280 °C / -40 °F to +536 °F
Pressure:	40 bar / 580 psi
Chemical resistance:	pH value 1-14

BuraTAL® HT 9650/HT

Application limits

Temperature:	-200 °C to +400 °C / -328 °F to +752 °F
Pressure:	300 bar / 4350 psi
Chemical resistance:	pH value 1-13

TYPICAL APPLICATION AREAS:

These sealing kits cover the required leakage values according to the VDI directives across the whole temperature range.

This means that the leakage values of $10^{-4} \frac{\text{mbar} \cdot \text{l}}{\text{s} \cdot \text{m}}$ are not reached at temperatures below 250 °C / 482 °F and $10^{-2} \frac{\text{mbar} \cdot \text{l}}{\text{s} \cdot \text{m}}$ are not reached at temperatures above 250 °C / 482 °F on the seal. The checking of this is assumed by a spring application system designed especially for this application. This so-called live loading system ensures the constant surface pressure on the sealing kits that consists of a combination of diverse packing rings as a chamber, sealing rings and flat seal as intermediate layers. The live loading system is designed according to the operating temperature and operating pressure (spring package) and set according to the assembly directive (checking gap between the spring sleeve and the stuffing box gland).

VALVE BALLS BALL BORE FLOW VERSIONS

CERAVALVE		K _{VS} and C _V flow coefficients for control valves with standard lengths																		
Flange size		Ball bore	Center Body																	
DIN DN	ANSI NPS		DN15		DN25		DN40		DN65		DN80		DN100		DN125		DN150			
			NPS ½	NPS 1	NPS 1 ½	NPS 2 ½	NPS 3	NPS 4	NPS 5	NPS 6										
		K _{VS}	C _V	K _{VS}	C _V	K _{VS}	C _V	K _{VS}	C _V	K _{VS}	C _V	K _{VS}	C _V	K _{VS}	C _V	K _{VS}	C _V			
15	½	triangular	12.2	14.2																
		full bore	14.6	17.0																
20	¾	triangular	14.1	16.5																
		full bore	19.1	22.3																
25	1	triangular	13.1	15.3	37.3	43.5														
		full bore	19.2	22.4	45.9	53.6														
32	1 ¼	triangular	11.5	13.4	41.7	48.7														
		full bore	17.3	20.2	62.1	72.5														
40	1 ½	triangular	9.4	11.0	36.5	42.6	89.1	104												
		full bore	15.5	18.1	62.4	72.8	127	148												
50	2	triangular	9.4	11.0	28.8	33.6	89.4	104												
		full bore	14.1	16.5	54.0	63.0	166	193												
65	2 ½	triangular			27.2	31.7	75.5	88.1	202	236										
		full bore			46.5	54.3	169	197	342	398										
80	3	triangular			26.4	30.8	64.5	75.3	178	207	311	363								
		full bore			39.8	46.4	140	163	433	505	529	617								
100	4	triangular					61.6	71.9	148	173	248	290	414	483						
		full bore					108	125	385	450	670	782	825	962						
125	5	triangular					60.0	70.0	138	160	232	271	335	391						
		full bore					101	118	285	333	573	668	922	1076	1392	1623				
150	6	triangular							132	154	215	250	297	346						
		full bore							258	301	482	563	778	907	1711	1996	2031	2369		
200	8	triangular											273	319						
		full bore											529	617	1458	1700	2649	3091		
250	10	triangular																		
		full bore													1147	1338	1917	2237		
300	12	triangular																		
		full bore															1532	1788		
350	14	triangular																		
		full bore															1380	1610		



The desired control behaviour of the valve is determined by the nominal diameter of the center housing and the geometry of the ball bore. Round or triangular bores can be rotated by between 0 and 90° and define exact opening cross-sections.

Special contours across all nominal diameters with adjusted K_{vs}/C_v values are available.

The installation lengths of the ball valves correspond to those of the control valves.

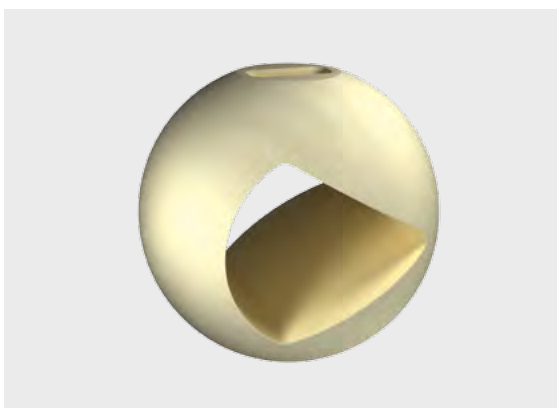

CHARACTERISTICS

Nominal diameter: DN 15-200 • 1/2" - 8"

Ball bore: triangle

Characteristic: equal percentage

Nominal diameter: DN 15-200 • 1/2" - 8"

Ball bore: round

Characteristic: equal percentage

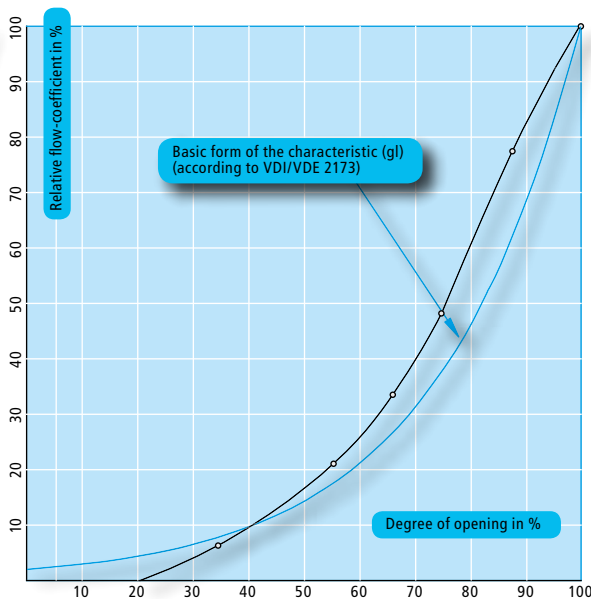
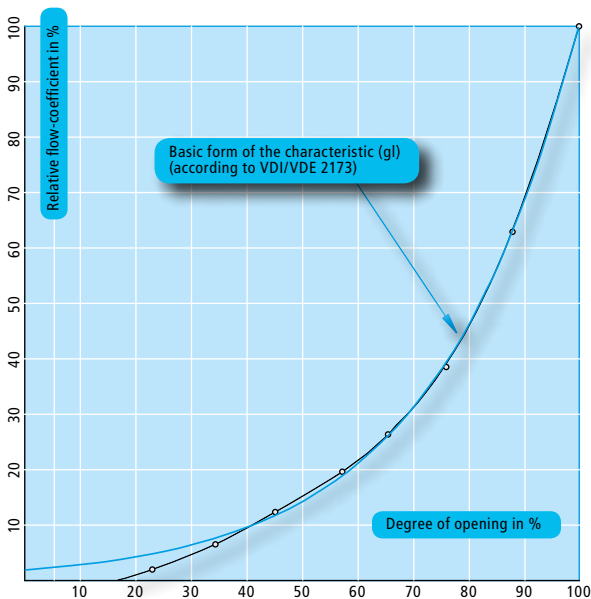

CERAMIC MATERIALS PROPERTIES – ADVANTAGES AND DISTINCTIVE FEATURES

CORROSION RESISTANCE

Compared to other materials, the corrosion resistance of the ceramic materials is significantly more higher and can be used in broader range on corrosive applications. Ceramics are completely resistant against the majority of solvents. Aqueous brines are generally no problem. The ceramics used are highly resistant against the majority of acids up to relatively high temperatures. Nevertheless, there are large differences that are to be observed. All oxidic ceramic materials are not resistant against fluorides for example. Some materials (e.g. Y-PSZ) are sensitive to water vapour (not hydrothermally resistant). It must be observed that mixtures of reagents generally react differently than the individual components.

PRESSURE RESISTANCE AND FLEXURAL STRENGTH

In contrast to metals, the mechanical strength properties of ceramic materials are different when bent, when under load and when under pressure. While the pressure resistance in almost all dense ceramics is many times higher than that of metals, the tensile and flexural strength must be closely observed.

The extremely high pressure resistance of Al_2O_3 can be an advantage, especially in the seat of a ball valve.

Even if the comparison of the strength values of metals and ceramics is problematic, it does demonstrate the difference in size:

Due to the high torque load, balls require materials with a high flexural strength. Therefore, the materials zirconium dioxide and silicon nitride are used for balls.

CERAMIC MATERIALS

Al_2O_3	Aluminium oxide
ZrO_2	Zirconium dioxide
SSiC	Silicon carbide
Si_3N_4	Silicon nitride

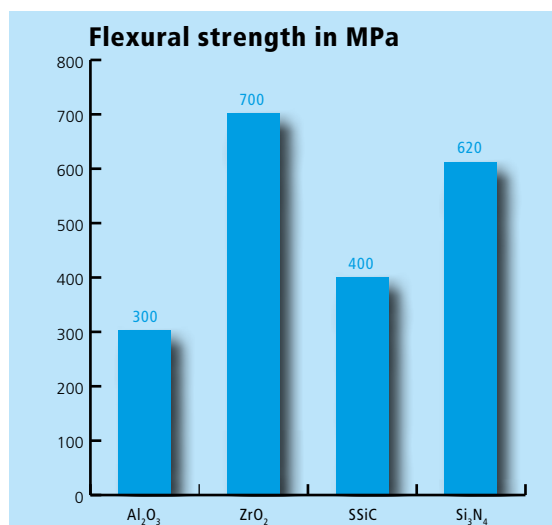
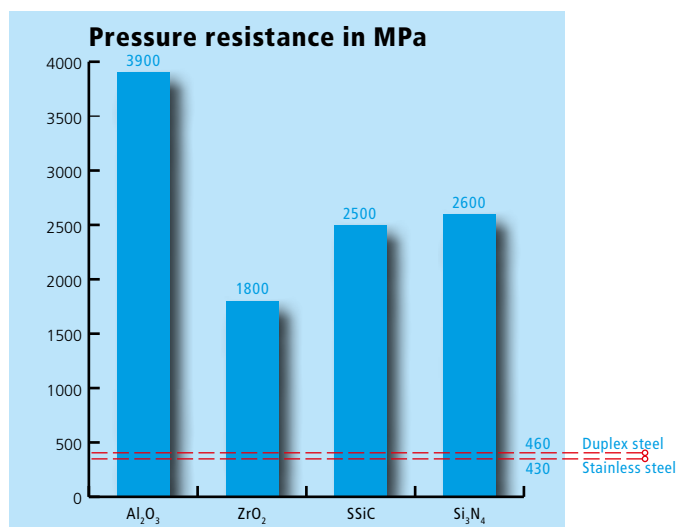

DENSITY

Weight is also generally saved when ceramics are used as these materials have a density up to 78% less than that of hard metal / 60% less than that of stainless steel.

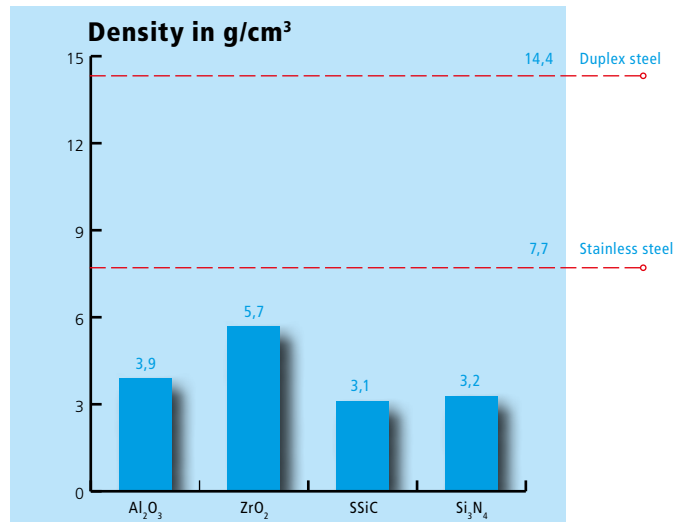

HARDNESS AND WEAR RESISTANCE

The wear resistance of components is significantly influenced by the respective type of load. Thanks to their extremely high hardness, ceramic materials have a wear resistance against friction that is many times higher than metals.

The mixture of loads that often occur in practice such as friction wear, radiation wear and impact wear as well as cavitations are generally absorbed better by ceramic components than metal components. All direct impact loads required closer observation.

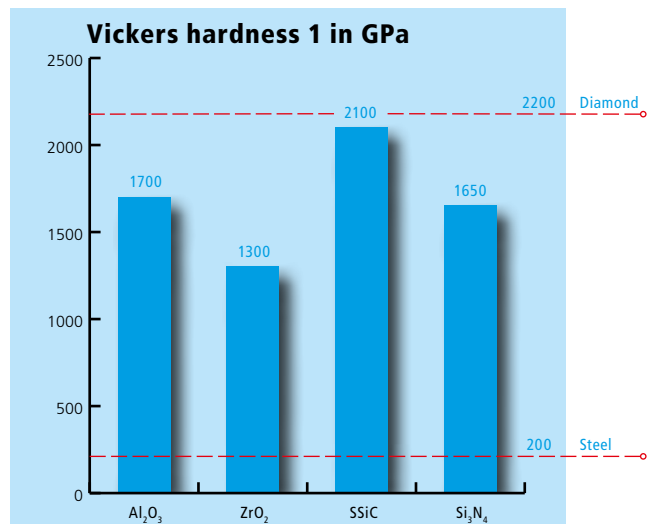

THERMO SHOCK RESISTANCE

In contrast to the maximum operating temperature, the thermo shock resistance must be closely observed. Ceramic components maintain their shape and strength as well as their further physical characteristics up to extremely high temperatures. In addition to the material dependency, the thermo shock resistance is also highly dependent upon the geometry. Simple geometric shapes such as pipes are less sensitive than such parts that have highly differing wall thicknesses for example.

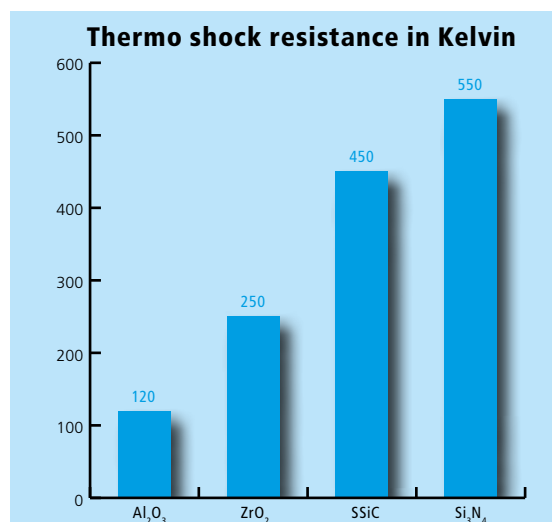

TORQUE VALUES

type	Shaft	Max. temperature	Bearing	Ball material	Center body		Recommended TORQUE in Nm at Δp up to												Max. permitted torque	Max. switchable pressure difference
					DIN	ANSI NPS	1bar	2bar	3bar	4bar	6bar	10bar	16bar	20bar	25bar	40bar	Nm	bar		
KS_	1.4462 / 2.4605	310 °C / 180 °C	Floating ball	Ceramic ZrO ₂ / Si ₃ N ₄	DN 15	½	12	12	12	12	12	12	12	12	16	40	80			
					DN 25	1	23	23	23	23	23	23	28	35	45	71	100	50		
					DN 40	1 ½	45	45	45	45	45	51	82	103	128		160	35		
					DN 65	2 ½	65	65	65	65	95	158					180	15		
					DN 80	3	116	116	116	116	150	170					190	10		
					DN 100	4	165	165	165	165	200						230	8		
					DN 125	5	250	250	250	250	330						340	6		
					DN 150	6	450	450	450	450							500	4		
KS_	1.4462 / 2.4605	310 °C / 180 °C	Floating ball	Steel 1.4112	DN 15	½	12	12	12	12	12	12	12	16	50	160				
					DN 25	1	23	23	23	23	23	23	28	35	45	71	130	100		
					DN 40	1 ½	45	45	45	45	45	51	82	103	128		160	35		
					DN 65	2 ½	65	65	65	65	95	158	215	250			250	20		
					DN 80	3	116	116	116	116	150	170					340	12		
					DN 100	4	165	165	165	165	150	270					520	10		
					DN 125	5	250	250	250	250	330	490					1800	10		
					DN 150	6	450	450	450	450	530	700					3000	10		
KA_	1.4462 / 2.4605	310 °C / 180 °C	Floating ball	Ceramic ZrO ₂ / Si ₃ N ₄	DN 15	½	12	12	12	12	12	12	15	18	23	36	40	40		
					DN 25	1	25	25	25	25	25	40	60	73	90		100	25		
					DN 40	1 ½	50	50	50	60	80	120					160	13		
					DN 65	2 ½	50	70	95	120	170						180	7		
					DN 80	3	80	120	150	180							190	5		
					DN 100	4	100	165	200								230	3		
					DN 125	5	190	340									340	2		
					DN 150	6	250	450									500	2		
KA_	1.4462 / 2.4605	310 °C / 180 °C	Floating ball	Steel 1.4112	DN 15	½	12	12	12	12	12	12	15	18	23	36	50	40		
					DN 25	1	25	25	25	25	25	40	60	73	90		130	30		
					DN 40	1 ½	50	50	50	60	80	160					160	13		
					DN 65	2 ½	70	70	95	120	170	250					250	10		
					DN 80	3	120	120	150	210	340						340	6		
					DN 100	4	200	250	380	470							520	4		
					DN 125	5	280	370	560	750	1110						1630	6		
					DN 150	6	360	750	1100	1550	2500						3000	6		
BR26 CERA	1.4462 / 2.4605	200 °C	Floating ball	Ceramic ZrO ₂	DN 15	½	12	12	12	12	12	12	12	16	40	40				
					DN 25	1	23	23	23	23	23	23	28	35	45	71	100	40		
					DN 40	1 ½	45	45	45	45	45	51	82	103	128		160	40		
					DN 50	2	45	45	45	45	45	51	82	103	128		160	40		
					DN 80	3	116	116	116	116	150	170					190	26		
					DN 100	4	165	165	165	165	200						230	13		

We reserve the right to make changes within the context of technical development. Date: May 2015

type	Shaft	Max. temperature	Bearing	Ball material	Center Housing	Recommended TORQUE in Nm at Δp up to										Max. permitted torque	Max. switchable pressure difference							
						ANSI NPS	DIN	1bar	2bar	3bar	4bar	6bar	10bar	16bar	20bar			25bar	40bar					
								Nm	bar															
KBR liquid conveying	Stainless steel 1.4301	310 °C	Trunnion mounted ball	Chromium chilled cast 30 EH	Floating ball	1	DN 25	70	70	70	70	70	70						380	16				
						1 ½	DN 40	80	80	80	80	80	80								425	16		
						2	DN 50	120	120	120	120	120	120									450	16	
						2 ½	DN 65	230	230	230	230	230	230									820	16	
						3	DN 80	270	270	270	270	270	270										820	16
						4	DN 100	330	330	330	330	330	330										820	10
						5	DN 125	550	550	550	550	550	550										1630	10
			6	DN 150	1050	1050	1050	1050	1050	1050										4000	10			
			7	DN 175	1250	1250	1250	1250	1250	1250										4000	10			
			8	DN 200	on request																			
			10	DN 250	on request																			
			12	DN 300	on request																			
			14	DN 350	on request																			
			KBR dust conveying	Stainless steel 1.4301	310 °C	Trunnion mounted ball	Chromium chilled cast 30 EH	Floating ball	1	DN 25	200	200	200	200	200	200						380	16	
1 ½	DN 40	230							230	230	230	230	230								425	16		
2	DN 50	290							290	290	290	290	290									450	16	
2 ½	DN 65	400							400	400	400	400	400									820	16	
3	DN 80	520							520	520	520	520	520										820	16
4	DN 100	680							680	680	680	680	680										820	10
5	DN 125	1110							1110	1110	1110	1110	1110										1630	10
6	DN 150	2000				2000	2000	2000	2000	2000										4000	10			
7	DN 175	2300				2300	2300	2300	2300	2300										4000	10			
8	DN 200	on request																						
10	DN 250	on request																						
12	DN 300	on request																						
14	DN 350	on request																						
KZ_	1.4462 / 2.4605	310 °C / 180 °C				Trunnion mounted ball	ZrO ₂ / Si ₃ N ₄	3	DN 80	300	300	300	300	300	350	360	380					430	20	
			4	DN 100	380			380	380	380	380	450	470							560	16			
			5	DN 125	580			580	580	580	580	880	920								950	16		
			6	DN 150	1200			1200	1200	1200	1200	1800									1800	10		
KG_	1.4462/2.4605	310 °C / 180 °C	Trunnion mounted ball	ZrO ₂ / Si ₃ N ₄	3	DN 80	200	200	200	200	200	250	250	360	370				430	25				
					4	DN 100	250	250	250	250	250	340	350	380						560	20			
					5	DN 125	450	450	450	450	450	650	810								950	18		
					6	DN 150	850	850	850	850	850	1300	1700								1800	16		
8	DN 200	1300	1300	1300	1300	1300	1800	2250									3750	16						

TORQUE VALUES

type	Shaft	Max. temperature	Bearing	Ball material	Center Body		Recommended TORQUE in in-lbs at Δp up to												Max. permitted torque	Max. switchable pressure difference		
							DIN	ANSI NPS	15 psi	30 psi	45 psi	60 psi	90 psi	145 psi	230 psi	290 psi	360 psi	580 psi			in-lbs	psi
KS_	1.4462 / 2.4605	310 °C / 180 °C	Floating ball	Ceramic ZrO ₂ / Si ₃ N ₄	DN 15	1/2	106	106	106	106	106	106	106	106	106	106	106	142	354	1160		
					DN 25	1	204	204	204	204	204	204	204	248	310	398	628	885	725			
					DN 40	1 1/2	398	398	398	398	398	398	451	726	912	1133		1420	508			
					DN 65	2 1/2	575	575	575	575	841	1400						1590	218			
					DN 80	3	1030	1030	1030	1030	1330	1500						1680	145			
					DN 100	4	1460	1460	1460	1460	1770							2040	116			
					DN 125	5	2210	2210	2210	2210	2920							3010	87			
					DN 150	6	3980	3980	3980	3980								4430	58			
KS_	1.4462 / 2.4605	310 °C / 180 °C	Floating ball	Steel 1.4112	DN 15	1/2	106	106	106	106	106	106	106	106	106	106	106	142	443	2321		
					DN 25	1	204	204	204	204	204	204	204	248	310	398	628	1150	1450			
					DN 40	1 1/2	398	398	398	398	398	451	726	912	1133			1420	508			
					DN 65	2 1/2	575	575	575	575	841	1400	1900	2210				2210	290			
					DN 80	3	1030	1030	1030	1030	1330	1500						3010	174			
					DN 100	4	1460	1460	1460	1460	2210	2390						4600	145			
					DN 125	5	2210	2210	2210	2210	2920	4340						16000	145			
					DN 150	6	3980	3980	3980	3980	4690	6200						26600	145			
KA_	1.4462 / 2.4605	310 °C / 180 °C	Floating ball	Ceramic ZrO ₂ / Si ₃ N ₄	DN 15	1/2	106	106	106	106	106	106	133	159	204	319		354	580			
					DN 25	1	221	221	221	221	221	354	531	646	797			885	363			
					DN 40	1 1/2	443	443	443	531	708	1060						1420	189			
					DN 65	2 1/2	443	620	841	1060	1500							1590	102			
					DN 80	3	708	1060	1330	1590								1690	73			
					DN 100	4	885	1460	1770									2040	44			
					DN 125	5	1680	3010										3010	29			
					DN 150	6	2210	3980										4430	29			
KA_	1.4462 / 2.4605	310 °C / 180 °C	Floating ball	Steel 1.4112	DN 15	1/2	106	106	106	106	106	106	133	159	204	319		443	580			
					DN 25	1	221	221	221	221	221	354	531	646	797			1150	435			
					DN 40	1 1/2	443	443	443	531	708	1420						1420	189			
					DN 65	2 1/2	620	620	841	1060	1500	2210						2210	145			
					DN 80	3	1060	1060	1330	1860	3010							3010	87			
					DN 100	4	1770	2210	3360	4160	5750							4600	58			
					DN 125	5	2480	3270	4960	6640	9820							14400	87			
					DN 150	6	3190	6640	9740	13700	22100							26600	87			
BR26 CERA	1.4462 / 2.4605	200 °C	Floating ball	Ceramic ZrO ₂	DN 15	1/2	106	106	106	106	106	106	106	106	106	106	142	355	580			
					DN 25	1	204	204	204	204	204	204	204	248	310	398	628	885	580			
					DN 32													885	580			
					DN 40	1 1/2	398	398	398	398	398	451	726	912	1133			1415	580			
					DN 50	2												1415	580			
					DN 65	2 1/2	575	575	575	575	841	1400						1595	375			
					DN 80	3	1030	1030	1030	1030	1330	1500						1680	290			
					DN 100	4	1460	1460	1460	1460	1770							2035	190			

type	Shaft	Max. temperature	Bearing	Ball material	Center Housing	Recommended TORQUE in lbs at Δp up to										Max. permitted torque	Max. switchable pressure difference					
						ANSI NPS	DIN	15 psi	30 psi	45 psi	60 psi	90 psi	145 psi	230 psi	290 psi			360 psi	580 psi	in-lbs	psi	
KBR liquid conveying	Stainless steel 1.4301	590 °F	Floating ball	Chromium chilled cast 30EH	1 ½	DN 40	708	708	708	708	708	708	708				3760	232				
					2	DN 50	1060	1060	1060	1060	1060	1060	1060				3980	232				
					2 ½	DN 65	2040	2040	2040	2040	2040	2040	2040				7260	232				
					3	DN 80	2390	2390	2390	2390	2390	2390	2390				7260	232				
					4	DN 100	2920	2920	2920	2920	2920	2920	2920				7260	145				
					5	DN 125	4870	4870	4870	4870	4870	4870					14400	145				
					6	DN 150	9290	9290	9290	9290	9290	9290					35400	145				
			7		DN 175	11100	11100	11100	11100	11100	11100					35400	145					
			8		DN 200	on request																
			10		DN 250	on request																
			12		DN 300	on request																
			14		DN 350	on request																
			KBR dust conveying		Stainless steel 1.4301	590 °F	Floating ball	Chromium chilled cast 30EH	1 ½	DN 40	2040	2040	2040	2040	2040	2040	2040				3760	232
									2	DN 50	2570	2570	2570	2570	2570	2570	2570				3980	232
2 ½	DN 65	3540		3540					3540	3540	3540	3540	3540				7260	232				
3	DN 80	4600		4600					4600	4600	4600	4600	4600				7260	232				
4	DN 100	6020		6020					6020	6020	6020	6020					7260	145				
5	DN 125	9820		9820					9820	9820	9820	9820					14400	145				
6	DN 150	17700		17700					17700	17700	17700	17700					35400	145				
7	DN 175	20400		20400			20400		20400	20400	20400					35400	145					
8	DN 200	on request																				
10	DN 250	on request																				
12	DN 300	on request																				
14	DN 350	on request																				
KZ_	1.4462 / 2.4605	590 °F / 356 °F		Trunnion mounted ball			ZrO ₂ / Si ₃ N ₄		3	DN 80	2660	2660	2660	2660	2660	3100	3190	3360			3810	290
									4	DN 100	3360	3360	3360	3360	3360	3980	4160				4960	232
			5		DN 125	5130		5130	5130	5130	5130	7790	8140				8410	232				
			6		DN 150	10600		10600	10600	10600	10600	15900					15900	145				
			8		DN 200	19500		19500	19500	19500	19500	26500					33200	145				
KG_	1.4462/2.4605	590 °F / 356 °F	Trunnion mounted ball	ZrO ₂ / Si ₃ N ₄	3	DN 80	1770	1770	1770	1770	1770	2210	2210	3190	3280		3810	363				
					4	DN 100	2210	2210	2210	2210	2210	3010	3100	3360			4960	290				
					5	DN 125	3980	3980	3980	3980	3980	5750	7170				8410	261				
					6	DN 150	7520	7520	7520	7520	7520	11500	15000				15900	232				
					8	DN 200	11500	11500	11500	11500	11500	15900	19900				33200	232				

CONNECTION DIMENSIONS

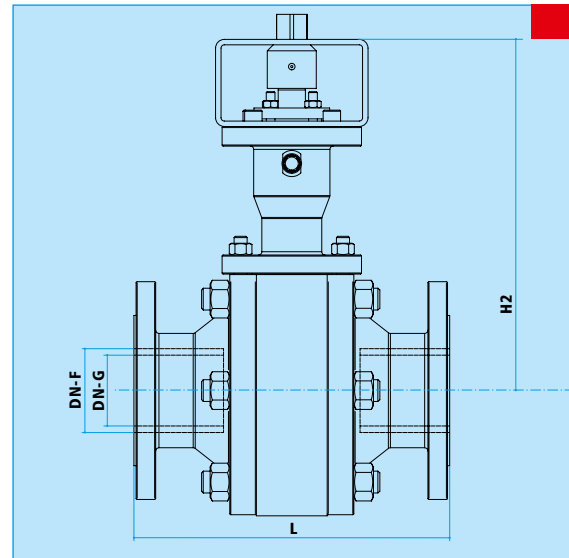
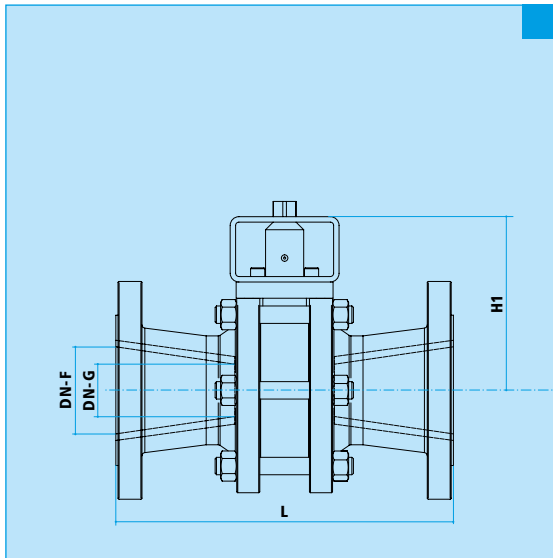

Size		Installation height DIN ISO 5211 (H1)											
DN-G		F05-VK14		F07-VK17		F10-VK22		F12-VK27		F14-VK36		F16-VK46	
DIN	ANSI / NPS	mm	inch	mm	inch	mm	inch	mm	inch	mm	inch	mm	inch
DN 15	½	124.0	4.88	124.0	4.88	144.0	5.67	-	-	-	-	-	-
DN 25	1	142.5	5.61	142.5	5.61	162.5	6.40	162.5	6.40	172.5	6.79	-	-
DN 40	1½	158.0	6.22	158.0	6.22	178.0	7.01	178.0	7.01	188.0	7.40	-	-
DN 65	2½	201.5	7.93	201.5	7.93	201.5	7.93	201.5	7.93	211.5	8.33	241.5	9.51
DN 80	3	216.0	8.50	216.0	8.50	216.0	8.50	216.0	8.50	226.0	8.90	256.0	10.08
DN 100	4	232.5	9.15	232.5	9.15	232.5	9.15	232.5	9.15	242.5	9.55	272.5	10.73
DN 125	5	-	-	-	-	253.5	11.12	253.5	11.12	253.5	12.93	328.5	12.93
DN 150	6	-	-	-	-	282.5	11.12	282.5	11.12	328.5	12.93	328.5	12.93
DN 200	8	-	-	-	-	-	-	-	-	-	-	-	-

Size		Installation length (L) EN 558											
DN-F		Series 1	Series 27	Series 37	Series 38	Series 3	Series 12						
DIN	ANSI / NPS	mm	mm	inch	mm	inch	mm	inch	mm	inch	mm		
DN 15	½	130	115	-	-	-	-	-	-	-	-	-	-
DN 20	¾	150	120	-	-	-	-	-	-	-	-	-	-
DN 25	1	160	125	7.25	184	7.75	197	5.00	127	-	-	-	-
DN 32	1¼	180	130	-	-	-	-	-	-	-	-	-	-
DN 40	1½	200	140	8.75	222	9.25	235	6.50	165	-	-	-	-
DN 50	2	230	150	10.00	254	10.50	267	7.00	178	-	-	-	-
DN 65	2½	290	170	11.40	290	-	-	7.50	190	-	-	-	-
DN 80	3	310	180	11.75	298	12.50	317	8.00	203	-	-	-	-
DN 100	4	350	190	13.88	352	14.50	368	9.00	229	-	-	-	-
DN 125	5	400	325	-	-	-	-	-	-	9.00	356	-	-
DN 150	6	480	350	17.75	451	18.62	473	-	-	14.50	394	-	-
DN 200	8	600	400	21.38	543	22.38	568	-	-	18.00	457	-	-
DN 250	10	730	450	26.50	673	27.87	708	-	-	-	-	-	-
DN 300	12	850	500	29.02	737	30.51	775	-	-	-	-	-	-

Size		Installation height DIN ISO 5211 (H2)											
		F05-VK14		F07-VK17		F10-VK22		F12-VK27		F14-VK36		F16-VK46	
DIN	ANSI / NPS	mm	inch	mm	inch	mm	inch	mm	inch	mm	inch	mm	inch
DN 15	½	224.0	8.82	224.0	8.82	244.0	9.61	-	-	-	-	-	-
DN 25	1	242.5	9.55	242.5	9.55	262.5	10.33	262.5	10.33	272.5	10.73	-	-
DN 40	1 ½	258.0	10.16	258.0	10.16	278.0	10.94	278.0	10.94	288.0	11.34	-	-
DN 65	2 ½	321.5	12.66	321.5	12.66	321.5	12.66	321.5	12.66	331.5	13.05	361.5	14.23
DN 80	3	336.0	13.23	336.0	13.23	336.0	13.23	336.0	13.23	346.0	13.62	376.0	14.80
DN 100	4	382.5	15.06	382.5	15.06	382.5	15.06	382.5	15.06	392.5	15.45	402.5	15.85
DN 125	5	-	-	-	-	403.5	15.89	403.5	15.89	403.5	15.89	403.5	15.89
DN 150	6	-	-	-	-	-	-	-	-	472.0	18.58	472.0	18.58

WEIGHTS

CERA VALVE valve weights in kg (lbs)									
Nominal diameter		Center Housing							
DIN	ANSI / NPS	DN 15	DN 25	DN 40	DN 65	DN 80	DN 100	DN 125	DN 150
		½	1	1 ½	2 ½	3	4	5	6
DN 15	½	6 (14)							
DN 20	¾	6 (14)							
DN 25	1	6 (14)	10 (22)						
DN 32	1 ¼	7 (15)	11 (24)						
DN 40	1 ½	7 (16)	12 (26)	18 (40)					
DN 50	2	8 (17)	15 (33)	18 (40)					
DN 65	2 ½		18 (40)	21 (46)	38 (84)				
DN 80	3		22 (49)	24 (53)	39 (86)	48 (106)			
DN 100	4			28 (62)	40 (88)	50 (110)	66 (146)		
DN 125	5				44 (97)	54 (119)	77 (170)	99 (218)	
DN 150	6				51 (112)	58 (128)	81 (179)	110 (243)	165 (364)
DN 200	8						105 (231)	140 (309)	177 (390)
DN 250	10							165 (364)	188 (414)
DN 300	12								233 (514)
DN 350	14								289 (637)

Example: Ball valve DN 80 - 40 - 80 or 3" - 1 ½" - 3"

CERA VALVE valve weights in kg (lbs)			
Installation length (L) EN 558			
Nominal diameter		KBR Series 27	BR26 CERA Series 1
DIN	ANSI / NPS		BR26 CERA Series 27
DN 15	½	-	2,6 (5)
DN 25	1	10 (22)	5 (11)
DN 32	1 ¼	11 (24)	-
DN 40	1 ½	12 (26)	9 (19)
DN 50	2	13 (29)	12 (26)
DN 65	2 ½	26 (57)	-
DN 80	3	34 (75)	28 (61)
DN 100	4	38 (84)	48 (105)
DN 125	5	80 (176)	-
DN 150	6	138 (304)	-
DN 175	7	178 (392)	-
DN 200	8	195 (430)	-

PRODUCTS AND SERVICES

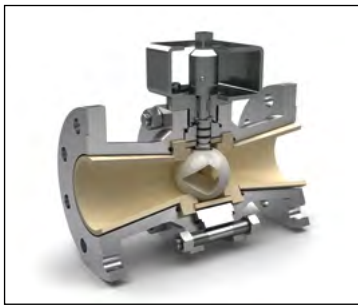

BALL VALVES

Cera System offers wear and corrosion resistant ball valves for open / close and control function. The use of ceramic lined valves is sensible in all cases where standard valves reach their limits (abrasion, corrosion, temperature and pressure). A large range of metallic and ceramic materials permits solutions for almost all industrial sectors. Special applications are solved in close cooperation with our customers.



SLIDING DISC VALVE

Cera System offers wear and corrosion resistant disc slide valves for open / close and control function. With this type of construction just the ceramic are wetted by the fluid. It is therefore suitable for highly corrosive media. Further advantages: Excellent control of small amounts containing solids - completely cavity free. The slide valve is available from DN 2 (5/16") up to DN 50 (2").



CERAMIC COMPONENTS

Cera System develops and produces customer-specific ceramic precision components in small batch sizes through to series production for the most diverse areas of application. Focal points are sealing and control discs for air conditioning, sanitary fittings as well as many other applications. Ceramic components for the sensor, food engineering and building services sectors round off our portfolio.

CERTIFICATES

ISO 9001:2008 • TA-Luft 2000 • Pressure equipment directive 97/23/EC Module H • Fire-safe according to EN ISO 10497:2004 • Safety shut-off device according to DIN EN ISO 23553-1 • Rostechndador • GOST R



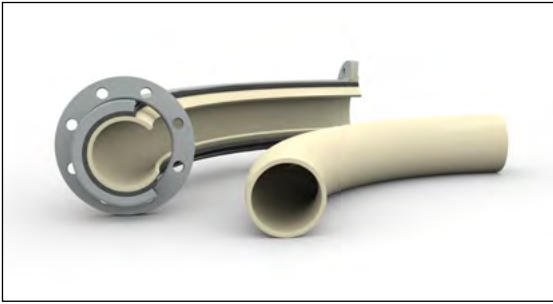

PIPE WEAR PROTECTION

Cera System offers wear resistant pipe elbows, Y and T parts as well as other shaped pieces. The most diverse of ceramics are used. The ceramic is solid (wall thickness approx. 6 mm (1/4")). All solutions are nominal size conformant, they can be assembled problem-free without having to adjust the pipelines. The clear width corresponds to the flange connection. Our speciality: the ceramic pipe elbows are actually curved (no apposition of straight sections).

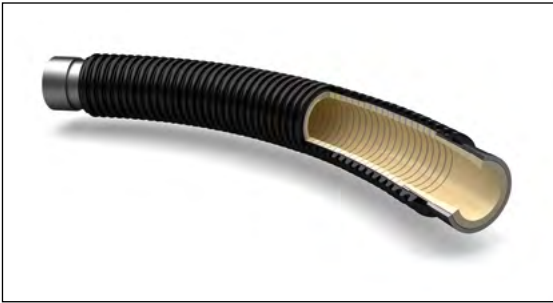

CERAMIC HOSES

Cera System supplies wear resistant flexible solutions. Ceramic hoses manufactured by Cera System can be used everywhere where hoses regularly wear and must be replaced. The hose consists of ceramic rings that are vulcanised together with special reinforced rubber materials. Pressures of up to 10 bar / 145 psi are permitted.

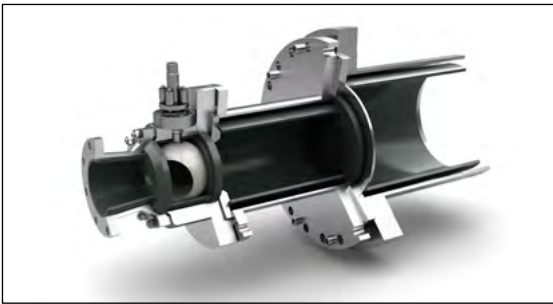

CERAMIC SYSTEM SOLUTIONS

Cera System offers system solutions with ceramic components. In-house development and sales engineers ensure for the complete design of ceramic systems and create economical, customer-specific complete solutions all over the world. Product developments in the coal gasification and photovoltaic sector are only examples of numerous other industry-specific applications.

