

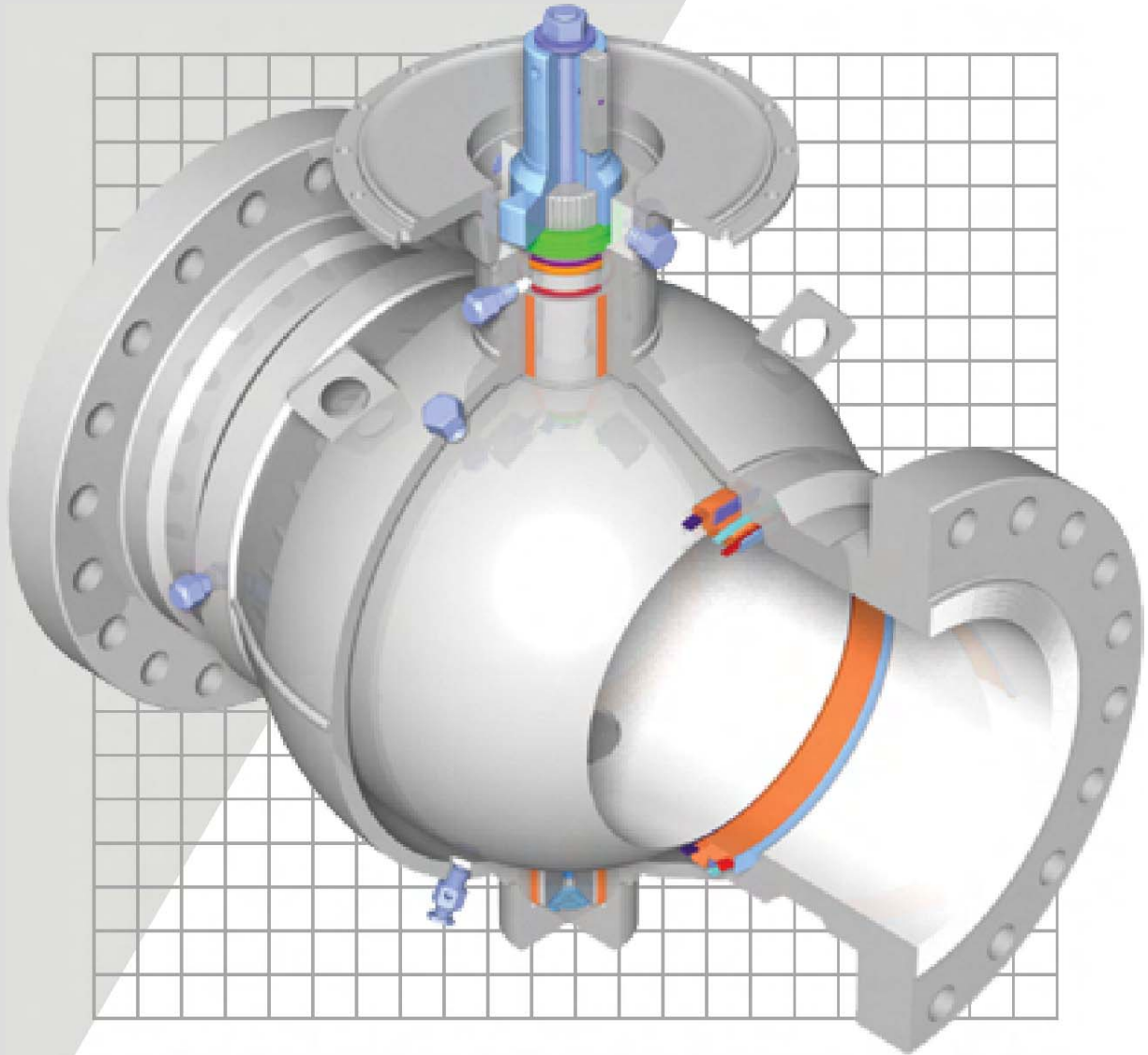

卡麦隆全焊接球阀



Cameron



目 录

全焊接球阀	
特点和优点	2, 3, 4 & 5
管线清管球发送器	6
附件	7
如何购买卡麦隆阀门	
标准、规范、材料	8 & 9
尺寸表	
ASME/ANSI Class 150~ 2500 (PN 20 ~PN 420)	
全通径和缩径球阀	10 ~ 22
API PRESSURE CLASS 2000, 3000 & 5000 psi	
全通径和缩径球阀	23, 24 & 25
尺寸表	
执行器安装信息	26, 27 & 28
管子尺寸表	29
商务条款和条件	30 & 31
商标信息	32

特点和优点

石油工业中最值得新来的阀门，综合了轻型锻件的强度和紧凑式球形设计。

卡麦隆全焊接球阀满足

ASME/ANSI150 磅级~2500磅级 (PN20~PN420) 和API2000~

API10000标准，锻钢制造确保了良好的一致晶粒结构和强度，阀门尺寸范围从2寸 to 56寸. (50 mm to 1400 mm).

作为专业为重负载设计、兼有免维护特性的顶尖球阀，卡麦隆全焊接球阀通常被许多工业应用所选用，其中包括：

- 气体输送
- 原油成品油管道
- 计量撬
- 脱水系统
- 气体分离
- 天然气储存
- 干燥系统
- 液化天然气厂
- 液化天然气管道
- 压缩机站
- 二氧化碳环境
- 海洋工程
- 海底管道

卡麦隆全焊接球阀的独特设计赋予了它在最小的重量下提供了最大的强度，同事对管道压力和应力的抵抗力最强。紧凑的球形阀体设计取消了阀体法兰和螺栓从而减小了外部尺寸并消除了潜在的外泄漏

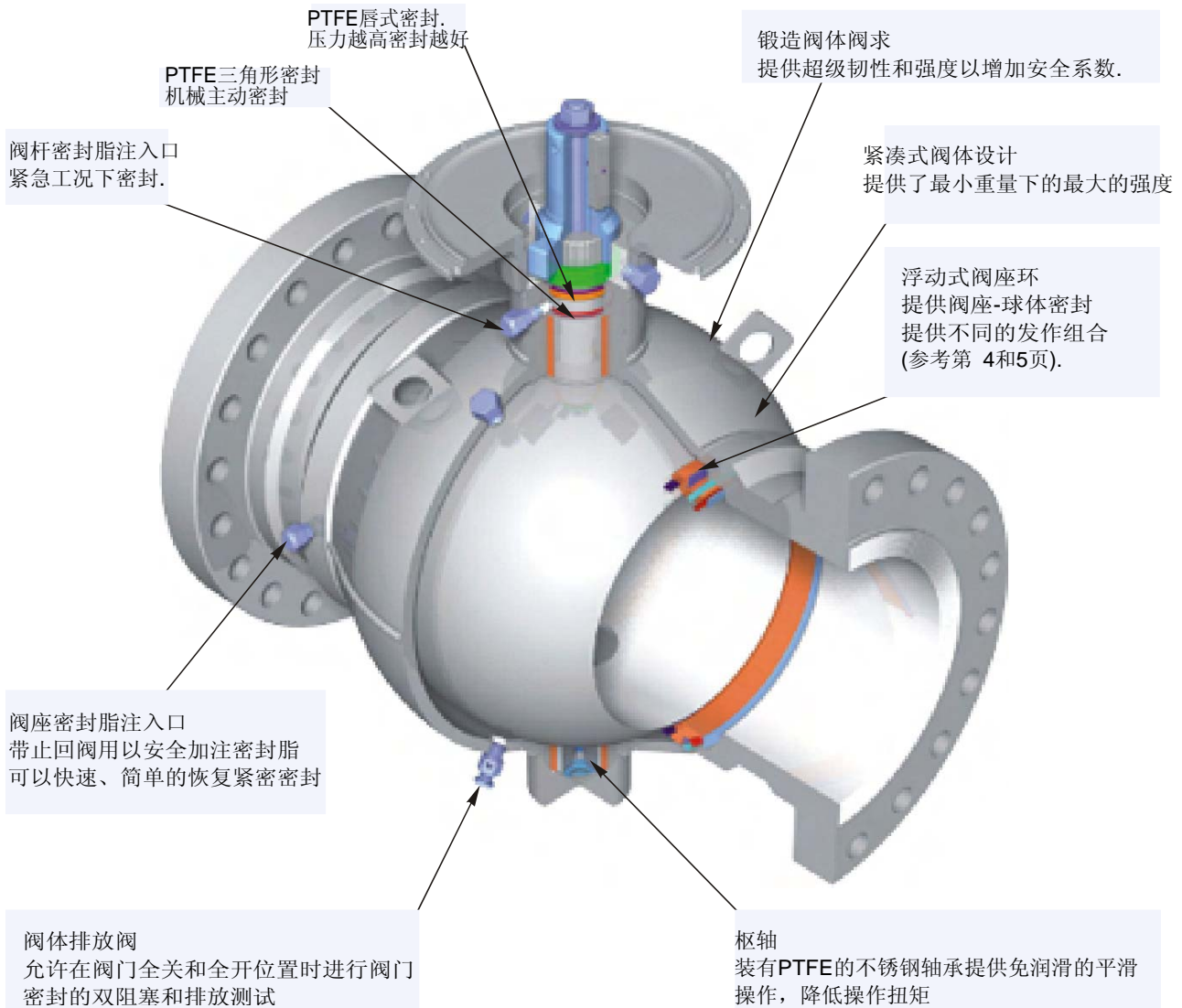



可更换的阀杆密封

在特殊情况下需要更换阀杆密封时，卡麦隆全焊接球阀的阀杆密封可以在不拆开阀门的条件下完成安全更换。首先需要将阀腔内的压力和进入阀杆区域的压力泄放（请您联系当地的卡麦隆阀门代表以获取维护程序）

提供下游工作的安全保护

阀门关闭并将排放阀打开时，管线介质不可能到达下游工作区域

安全防火测试

卡麦隆全焊接球阀满足 API 6FA, API 607、ISO 10497 标准。

防火测试程序一直在发展。如果工业标准或者用户要求和上述标准有变化，请联系您当地的卡麦隆阀门代表。

标准和规格
(见第8页的规格细节)

尺寸

- 2 in. through 56 in.
(50 mm through 1400 mm)
Full, Reduced and Venturi Bore

压力等级

- ASME/ANSI Class 150 through 2500
(PN 20 through PN 420)
API 2000 through 10,000 psi

操作温度

- From -50°F to 375°F (-46°C to 190°C)

端部连接

- 法兰、焊接和一端法兰一端焊接，
阀体形式
- 球形全焊接

标准材料

- 锻钢

可选材料

- 阀座/密封阀芯可选项包括：常规、防腐、耐酸 (NACE MR0175)

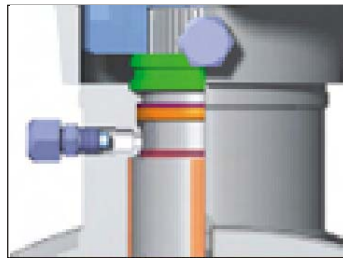

阀杆密封

PTFE三角密封和唇形密封共同组成阀杆上部区域密封，PTFE是低摩擦不老化的材料，不会产生快速失压爆破，对于2寸以上阀门的阀杆，还将提供阀杆密封脂注入系统用以建立阀杆的二级密封

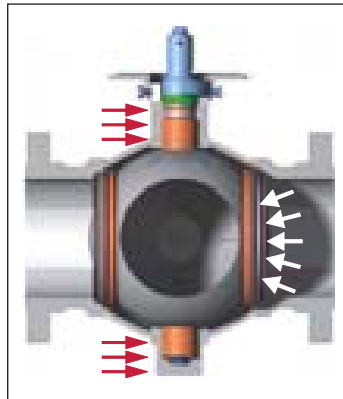

枢轴固定球保证较低的操作扭矩

无论尺寸大小压力等级高低，每台卡麦隆阀门均采用枢轴式固定球。高强度的锻钢阀杆由外包PTFE的不锈钢枢轴支撑做平滑精确的转动。枢轴支撑的阀杆可以吸收管线压力产生的推力，防止阀球和阀座之间的摩擦增加，因此即使在全压差下，操作扭矩依然保持很低。

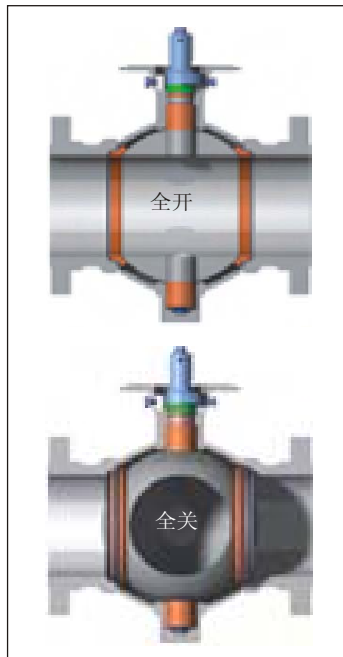

双关断与排放

无论阀门处于全开或者全关位置，阀座环都能将阀腔与球体上下游管线压力隔离，阀腔可放空或者通过阀体排污口排放。

当卡麦隆阀门关断并排放时可以实现以下功能：

测试阀门性能

卡麦隆球阀阀腔排空时可以证明阀座密封的完好性，对设备进行维护之前可在阀门开或关时进行该测试，通过确认阀门的完整性，可以避免不可预见的阀门泄露

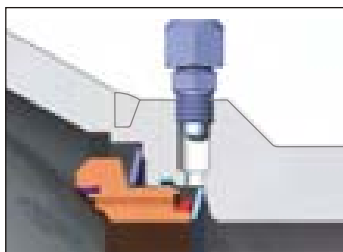

二级阀座密封

如果异物损坏了密封面，二级阀座密封脂注入系统可以提供一种快速简单的恢复紧急关断的方法，如有必要，密封脂注入系统也可用于周期性清洗阀座环密封区域

标准阀座设计

在自60年代初即开始的多年应用中，卡麦隆球阀的标准阀座构造已经证明了自身设计的正确性，该标准阀座配置可在所有卡麦隆全焊接阀门中提供，并且拥有如前所述的各项特点和优点

特点和优点

上游密封

低压时，阀座的抱球密封通过板式弹簧实现，高压时，管线压力会加强阀座的抱球密封

阀腔压力自动内部泄放

阀腔超压泄放是自动的，可有效地避免危险的压力增加，一旦阀腔压力超出下游压力约200Psi时，会将下游阀座推离阀球体，使压力泄放到管道中

旋转阀座

14寸 (DN350 mm)及以上尺寸的卡麦隆球阀配有独特的旋转阀座,每次阀门关闭时两侧阀座均旋转 15° 使受流体冲刷的阀座关键部位总是新的密封面，从而使阀座磨损保持均匀

阀座磨损均匀

当阀门接近全关或者刚刚打开时，阀座的窄点位置（9点钟位置）会受到介质的告诉冲刷，该位置是阀座密封磨损最严重的区域，并且是大部分阀门泄露通道的起点，而旋转阀座设计将窄点磨损均匀地分布在整个密封面上因此大大增加了阀座的使用寿命

防止阻塞

在某些应用中一些有害的沉积物会堆积在阀座环上，这会引起阀座卡死或者无法正常密封，具有独特旋转发座的卡麦隆全焊接球阀能够适应这些可的环境，当阀座旋转时可以破坏或者避免异物堆积

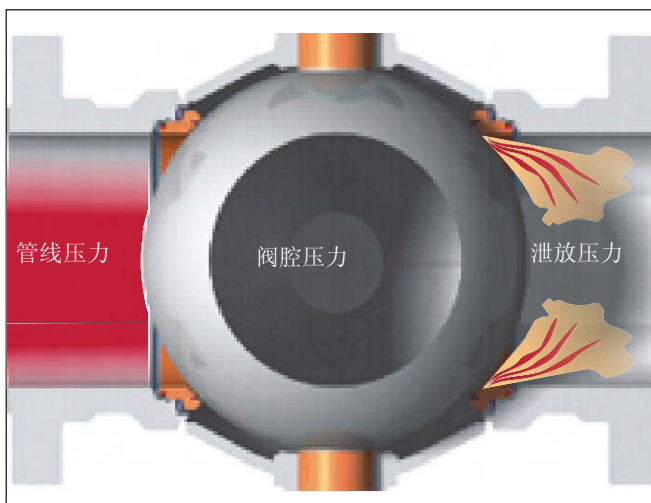
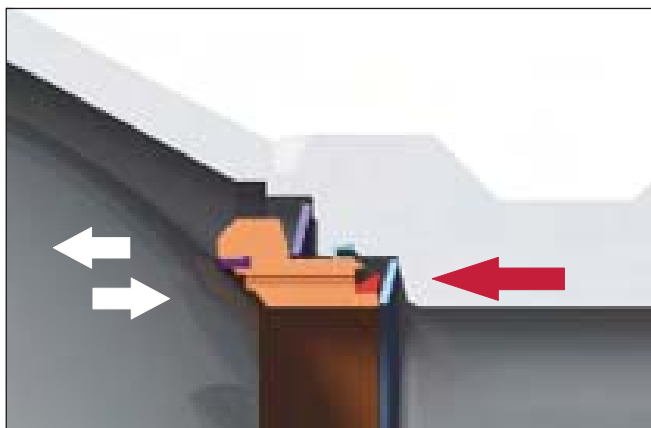

可选阀座设计

卡麦隆全焊接球阀也可以提供双活塞效应阀座和金属对金属密封阀座，以满足各种应用和用户不同需求

双活塞效应阀座

传统上游密封，

上游压力会将可双向运动的阀体/阀座密封推向密封容槽的前密封端面，这样阀座背面的受压面积大于阀座靠球的一侧受压面积，因此上游压力推动阀座抱球密封

下游密封

阀体/阀座密封在阀腔压力作用下被推向密封容槽的后密封端面，这样阀座背面的受压面积同样大于阀座靠球的一侧受压面积，因此下游压力推动阀座抱球密封

金属对金属密封阀座

对于软密封不适合的恶劣应用工况，卡麦隆可以提供金属对金属的密封设计。此设计在阀球和阀座表面均采用碳化钨涂层，因此具备高防腐性能和耐磨性能，适合高磨损环境，这种阀座采用上游密封和自泄式设计

弹性密封材料

同时阀座环配置一个小的弹性密封来实现两个作用：一是擦净阀球表面以避免表面损坏；二是在低压条件下实现气泡级密封

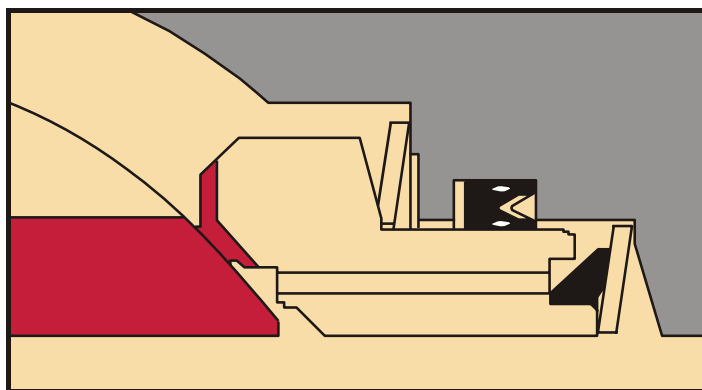
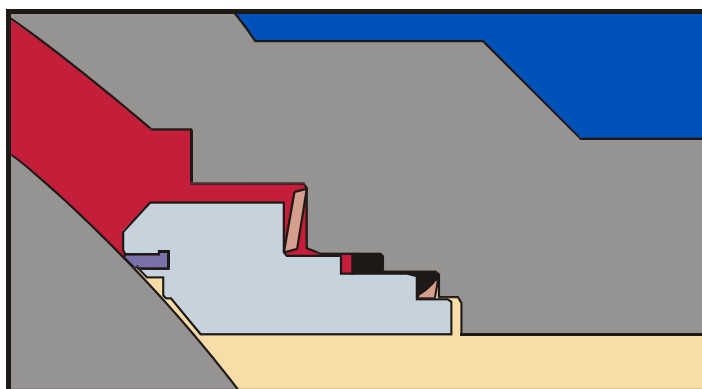
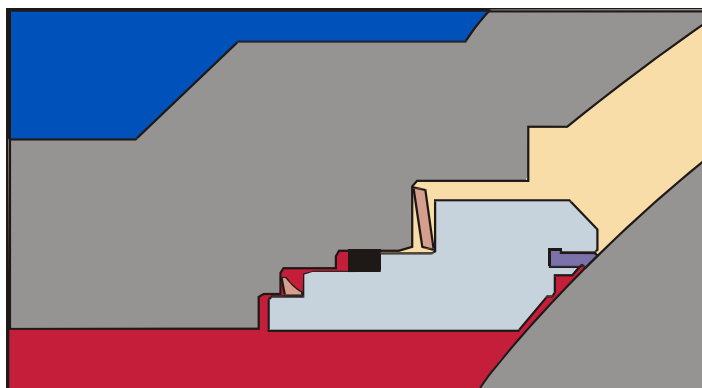

标准和规格

双活塞效应阀座 - T32

尺寸

- 8 in. (200 mm) through 48 in. (1200 mm)

压力等级

- ASME/ANSI Class 150 through 900 (PN 20 through PN 150)

操作温度

- -50°F to 250°F (-46°C to 121°C)

金属对金属 - T34

尺寸

- 2 in. (50 mm) through 48 in. (1200 mm)

压力等级

- ASME/ANSI Class 150 (PN 20) through API 10,000

操作温度

- -50°F to 375°F (-46°C to 190°C)

卡麦隆在线清管球发送器

多年的应用实际证明，卡麦隆在线清管球发送器具有超越传统发球系统的诸多优点。

特点和优点

节省投资

卡麦隆发球器的独特设计大大减少了建造一套发球系统的费用。此设计将本来需要三套阀门的系统变成了只需要一台干线阀门。传统的设计需要一台干线截断阀、一台发送阀、一台旁通阀。

卡麦隆在线发球器完成了干线截断阀和发送阀两者的功能，清管球可以直接塞入干线因此不需要旁通阀，减少了两台阀门及配管和支撑节省了整体投资

易于安装

卡麦隆的设计使得安装变得简单易行，对于一个已经建成的集输系统，卡麦隆发球球阀无需大的改造即可容易的安装到系统中

关断阀

卡麦隆发球球阀具有标准卡麦隆球阀的所有特点，因此它同时也可以作为您系统中的关断阀使用

利于现场操作

现场发送清管球时，现场人员更能体会到卡麦隆发球球阀的快速和便捷

可供货尺寸

卡麦隆可提供用于2 寸. to 30 寸. (DN50 mm到DN 750 mm)清管球的发球器。

多个清管球

发球球阀可配延长筒，这样用户便可通过简单地操作阀门发送多个清管球

其它可选配置

以下可选项帮助卡麦隆清管球发送器适合更多的应用：

手动齿轮操作器、气动、液动、气液联动和电动执行器、袖管（焊接过渡段）



发送顺序
(俯视图)

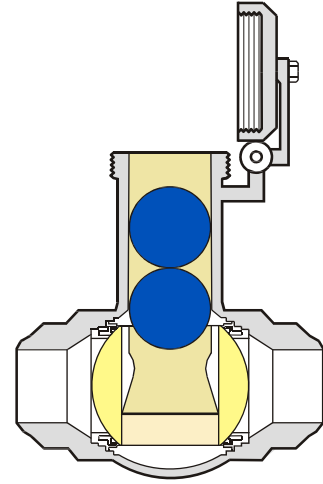

1. 阀门关闭
2. 阀体放空
3. 铰链门打开装入清管球

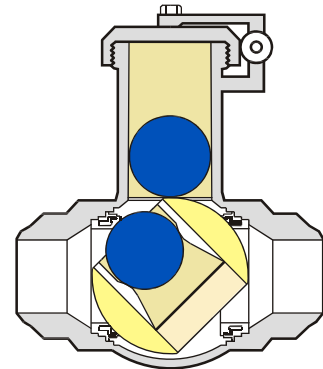

4. 延长筒允许装入多个清管球
5. 铰链门关闭
6. 阀体重新进压。
7. 阀门打开

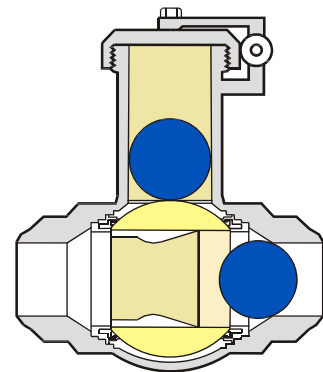

8. 清管球处于发送位置

附 件

高品质的卡麦隆附件使卡麦隆全焊接球阀能够适应更广泛的应用环境

延长阀杆

在必须埋地应用环境中，延长阀杆提供了地上操作的可能性
卡麦隆延长阀杆为埋地环境设计制造，多年全球范围的应用实践证明了其自身的可靠性

海底设计

为满足海底环境的需要，卡麦隆全焊接球阀可以提供特殊的涂层和执行机构，具有同样可靠的性能

直角操作

在安装空间狭小的地方，卡麦隆球阀可以安装一个直角延长杆，阀门操作从正常位置旋转90°，从而允许阀门顶部更大空间并且操作人员更容易操作。



如何购买卡麦隆球阀

购买卡麦隆全焊接球阀时必须确认一下要求:

1. 阀门代码 (见下表).
2. 压力等级 (ASME/ANSI 600 lb, API 3000 psi).
3. 端部和尺寸.
4. 连接端类型 (可提供不对等连接端).对于焊接端阀门需要指明内径、外径、壁厚和管材等级,
5. 操作机构类型.
6. 阀杆延长杆, 如果需要需指明阀门中心线至手轮中心线距离, 或者至执行机构装配法兰上面的距离.
7. 阀门内件材质.
8. 附件, (吊耳锁定装置等.).手轮包含在阀门中, 但是手柄需要单独购买, 如需要卡麦隆可提供关于特殊选材和API相关的信息

当购买另外厂家的执行机构来配卡麦隆球阀时须要指明以下要求:

1. 阀门尺寸和压力等级, 如果在现场更换阀门, 须要告知当前执行器.
2. 在正常和非正常情况下阀门的最大压差
3. 开关速度, 大致的开关频率.
4. 操作器类型(电动、液动、气动等).
5. 介质情况;
如果电动: 电压、频率、单相、三相, 开始或者防爆电机等
如果是液动或者气动: 操作介质、压力等.
6. 附件和控制要求;
限位开关、仪表、阀门、储罐、泵等

80	06	0	1	-	2	-	1																																																																																																					
规范	压力等级	口径	连接端		操作机构		材料																																																																																																					
<table border="1"> <tr><td>80</td><td>ASME/ANSI</td></tr> <tr><td>81</td><td>API</td></tr> <tr><td>82</td><td>AFNOR</td></tr> <tr><td>83</td><td>DIN</td></tr> <tr><td>84</td><td>UNI</td></tr> </table>	80	ASME/ANSI	81	API	82	AFNOR	83	DIN	84	UNI	<table border="1"> <tr><td>01</td><td>ASME/ANSI 150</td></tr> <tr><td>03</td><td>ASME/ANSI 300</td></tr> <tr><td>04</td><td>ASME/ANSI 400</td></tr> <tr><td>06</td><td>ASME/ANSI 600</td></tr> <tr><td>09</td><td>ASME/ANSI 900</td></tr> <tr><td>15</td><td>ASME/ANSI 1500</td></tr> <tr><td>25</td><td>ASME/ANSI 2500</td></tr> <tr><td>20</td><td>API 2000</td></tr> <tr><td>30</td><td>API 3000</td></tr> <tr><td>50</td><td>API 5000</td></tr> </table>	01	ASME/ANSI 150	03	ASME/ANSI 300	04	ASME/ANSI 400	06	ASME/ANSI 600	09	ASME/ANSI 900	15	ASME/ANSI 1500	25	ASME/ANSI 2500	20	API 2000	30	API 3000	50	API 5000	<table border="1"> <tr><td>0</td><td>Full</td></tr> <tr><td>7</td><td>Reduced</td></tr> <tr><td>4</td><td>Venturi</td></tr> <tr><td>9</td><td>All Others</td></tr> </table> <table border="1"> <tr><td>1</td><td>RF/RF</td></tr> <tr><td>2</td><td>WE/WE</td></tr> <tr><td>3</td><td>RF/WE</td></tr> <tr><td>4</td><td>RTJ/RTJ</td></tr> <tr><td>5</td><td>RTJ/WE</td></tr> <tr><td>9</td><td>All Others</td></tr> </table>	0	Full	7	Reduced	4	Venturi	9	All Others	1	RF/RF	2	WE/WE	3	RF/WE	4	RTJ/RTJ	5	RTJ/WE	9	All Others	<table border="1"> <tr><td>1</td><td>Lever</td></tr> <tr><td>1A</td><td>Extension Lever</td></tr> <tr><td>2</td><td>Worm gear</td></tr> <tr><td>2A</td><td>Extension Worm Gear</td></tr> <tr><td>4</td><td>Subsea Gear</td></tr> <tr><td>4A</td><td>Subsea Gear 300 feet +</td></tr> <tr><td>7</td><td>Direct Stem</td></tr> <tr><td>7A</td><td>Extension Direct Stem</td></tr> <tr><td>8</td><td>Worm Gear/Adapted</td></tr> <tr><td>8A</td><td>Extension Worm Gear/Adapted</td></tr> <tr><td>22</td><td>Square</td></tr> <tr><td>22A</td><td>Extension Square Nut/Mtg/Flg</td></tr> <tr><td>23</td><td>Worm Gear with 2 inch Square Operating Nut</td></tr> <tr><td>23A</td><td>Worm Gear with Right Angle Pinion Shaft Extension and 2 inch Square Operating Nut</td></tr> </table>	1	Lever	1A	Extension Lever	2	Worm gear	2A	Extension Worm Gear	4	Subsea Gear	4A	Subsea Gear 300 feet +	7	Direct Stem	7A	Extension Direct Stem	8	Worm Gear/Adapted	8A	Extension Worm Gear/Adapted	22	Square	22A	Extension Square Nut/Mtg/Flg	23	Worm Gear with 2 inch Square Operating Nut	23A	Worm Gear with Right Angle Pinion Shaft Extension and 2 inch Square Operating Nut	<table border="1"> <tr><td>1</td><td>Standard (150-1500)</td></tr> <tr><td>2</td><td>Standard API (2000-5000)</td></tr> <tr><td>4</td><td>Hi-Temp Teflon (150-600)</td></tr> <tr><td>8</td><td>Lo-Temp Nylon (150-2500)</td></tr> <tr><td>123</td><td>Pressure Regulating (150-1500)</td></tr> <tr><td>212</td><td>NACE (150-2500)</td></tr> <tr><td>213</td><td>NACE (2000-5000)</td></tr> <tr><td>214</td><td>Tefzel/NACE (150-1500)</td></tr> <tr><td>215</td><td>Tefzel/NACE (2000-5000)</td></tr> <tr><td>216</td><td>NACE/Lo-Temp (150-2500)</td></tr> <tr><td>217</td><td>NACE/Lo-Temp (2000-5000)</td></tr> <tr><td>222</td><td>NACE/Hi-Temp (150-600)</td></tr> <tr><td>259</td><td>NACE/316 Inlay (150-2500)</td></tr> </table>	1	Standard (150-1500)	2	Standard API (2000-5000)	4	Hi-Temp Teflon (150-600)	8	Lo-Temp Nylon (150-2500)	123	Pressure Regulating (150-1500)	212	NACE (150-2500)	213	NACE (2000-5000)	214	Tefzel/NACE (150-1500)	215	Tefzel/NACE (2000-5000)	216	NACE/Lo-Temp (150-2500)	217	NACE/Lo-Temp (2000-5000)	222	NACE/Hi-Temp (150-600)	259	NACE/316 Inlay (150-2500)
80	ASME/ANSI																																																																																																											
81	API																																																																																																											
82	AFNOR																																																																																																											
83	DIN																																																																																																											
84	UNI																																																																																																											
01	ASME/ANSI 150																																																																																																											
03	ASME/ANSI 300																																																																																																											
04	ASME/ANSI 400																																																																																																											
06	ASME/ANSI 600																																																																																																											
09	ASME/ANSI 900																																																																																																											
15	ASME/ANSI 1500																																																																																																											
25	ASME/ANSI 2500																																																																																																											
20	API 2000																																																																																																											
30	API 3000																																																																																																											
50	API 5000																																																																																																											
0	Full																																																																																																											
7	Reduced																																																																																																											
4	Venturi																																																																																																											
9	All Others																																																																																																											
1	RF/RF																																																																																																											
2	WE/WE																																																																																																											
3	RF/WE																																																																																																											
4	RTJ/RTJ																																																																																																											
5	RTJ/WE																																																																																																											
9	All Others																																																																																																											
1	Lever																																																																																																											
1A	Extension Lever																																																																																																											
2	Worm gear																																																																																																											
2A	Extension Worm Gear																																																																																																											
4	Subsea Gear																																																																																																											
4A	Subsea Gear 300 feet +																																																																																																											
7	Direct Stem																																																																																																											
7A	Extension Direct Stem																																																																																																											
8	Worm Gear/Adapted																																																																																																											
8A	Extension Worm Gear/Adapted																																																																																																											
22	Square																																																																																																											
22A	Extension Square Nut/Mtg/Flg																																																																																																											
23	Worm Gear with 2 inch Square Operating Nut																																																																																																											
23A	Worm Gear with Right Angle Pinion Shaft Extension and 2 inch Square Operating Nut																																																																																																											
1	Standard (150-1500)																																																																																																											
2	Standard API (2000-5000)																																																																																																											
4	Hi-Temp Teflon (150-600)																																																																																																											
8	Lo-Temp Nylon (150-2500)																																																																																																											
123	Pressure Regulating (150-1500)																																																																																																											
212	NACE (150-2500)																																																																																																											
213	NACE (2000-5000)																																																																																																											
214	Tefzel/NACE (150-1500)																																																																																																											
215	Tefzel/NACE (2000-5000)																																																																																																											
216	NACE/Lo-Temp (150-2500)																																																																																																											
217	NACE/Lo-Temp (2000-5000)																																																																																																											
222	NACE/Hi-Temp (150-600)																																																																																																											
259	NACE/316 Inlay (150-2500)																																																																																																											

标准、规范和材料

卡麦隆全焊接球阀的压力、温度等级和尺寸遵循以下一个或者多个规范:

ASME/ANSI, API-6D, API-6A, DIN, AFNOR, British Standards, ISO 9000 and ISO 14313.

标准阀门选材:

压力范围	ASME/ANSI Class 150-2500 (PN 20-PN 420)
温度范围	-20°F to 250°F (-29°C to 121°C)
阀体	ASTM A350 Gr. LF-2(M)
端部连接	ASTM A350 Gr. LF-2(M)
阀球	ASTM A694 Gr. F50(M) Chrome Plated or ENP
阀座环	AISI 1040
阀座预紧弹簧	AISI 1040
阀杆密封	PTFE Lip
唇式密封	PTFE 阀
座内嵌	Nylon

可根据要求提供其他材料.

可选阀门材料

选材	压力等级	温度范围	Trim Numbers (NACE MR0175)	
			常规	
标准	ASME/ANSI Class 150 - 2500	-20°F to 250°F (-29°C to 121°C)	1	212
	API 2000-5000	-20°F to 250°F (-29°C to 121°C)	2	213
低温	ASME/ANSI Class 150 - 2500	-50°F to 250°F (-46°C to 121°C)	8	216
	API 2000-5000	-50°F to 250°F (-46°C to 121°C)	-	217
高温	ASME/ANSI Class 150 - 600	-20°F to 375°F (-29°C to 190°C)	4	222
乙烯聚四氟(酸性)	ASME/ANSI Class 150 - 1500	-20°F to 300°F (-29°C to 149°C)	140	214
	API 2000-5000	-20°F to 300°F (-29°C to 149°C)	108	215
乙烯聚四氟	ASME/ANSI Class 150 - 1500	-50°F to 300°F (-46°C to 149°C)	223-	
	API 2000-5000	-50°F to 300°F (-46°C to 149°C)	-	
内部双相不锈钢	ASME/ANSI Class 150 - 1500	-20°F to 250°F (-29°C to 121°C)	-	276
全双相不锈钢	ASME/ANSI Class 150 - 1500	-50°F to 250°F (-46°C to 121°C)	-	504

材料:

Materials used in ball valve construction are broadly equivalent at all Cooper Cameron Valves manufacturing plants. However, the availability of local supplies, the need to conform to national standards and to offer various trims may necessitate some variations. In corrosive applications, valve trims may be offered using various types of alloys and stainless steels. For more information on material specifications and properties, please contact your local Cooper Cameron Valves representative.

扭矩信息:

Please contact your Cooper Cameron Valves representative to obtain a copy of the engineering bulletin which provides detailed torque information for sizing of power actuators.

法兰端和焊接端阀门尺寸代码:

- A 面对面长度
- B 通径尺寸r
- C 中心线到底部
- D1 法兰外径
- D2 法兰内径
- E 球型阀体尺寸

卡麦隆手动齿轮箱操作器代码:

- G 手轮直径
- H 手柄操作阀门通径中心到方形驱动螺母顶部, 齿轮箱操作阀门: 通径中心至手轮中心
- L 通径中心到手柄末端

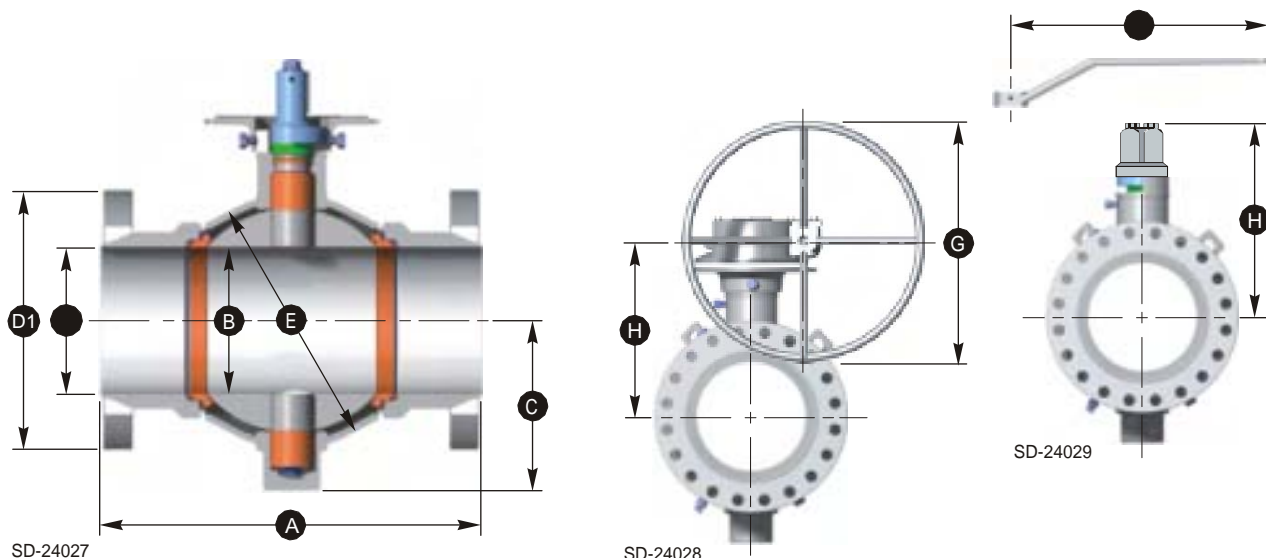

Cameron

TC1455
12/04 NP-5M

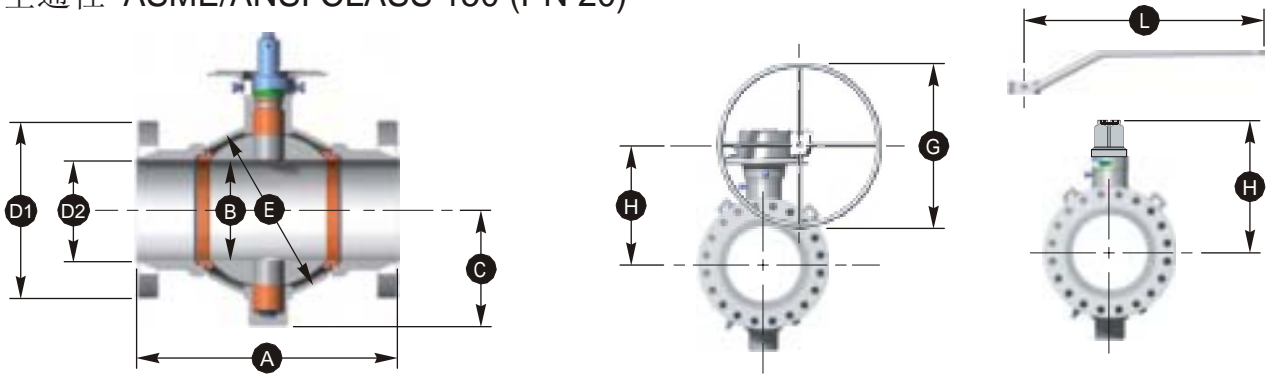
全通径 ASME/ANSI CLASS 150 (PN 20)

尺寸

英制 in.	Ball 公制 Bore	Ball Size	Flanged		Dia. D ₁	Dia. D ₂	Weld End + Length A	C.L. to Bottom C	Body Sphere E	Lever Length L	Diameter Handwheel for Gear G	C.L. to Handwheel C.L. H	Valve lb. Flange	Weld
			RF Length	RTJ Length										
2	2.06	1.0	7.0	7.5	6.00	2.06	11.0□	3.94	5.00	24	-	6.34	39	45
3	3.13	1.0	8.0	8.5	7.50	3.13	12.5□	5.12	6.75	24	-	7.44	62	75
4	4.06	1.5	9.0	9.5	9.00	4.06	14.0	5.94	8.50	36	-	8.43	115	100
6	6.00	1.5	15.5	16.0	11.00	6.00	18.0	7.91	11.25	36	-	10.43	200	225
8	8.00	2.0	18.0	18.5	13.50	8.00	21.5□	10.00	15.50	-	18	12.55	428	450
10	10.00	2.0	21.0	21.5	16.00	10.00	23.5□	12.12	18.50	-	18	14.54	705	650
12	12.00	3.0	24.0	24.5	19.00	12.00	26.5□	14.50	22.36	-	18	20.14	1210	1100
14	13.25	3.0	27.0	27.5	21.00	13.25	28.5*	14.64	24.00	-	24	21.16	1330	1230
16	15.25	3.0	30.0	30.5	23.50	15.25	30.5*	16.01	26.32	-	24	22.52	1650	1550
18	17.25	4.0	34.0	34.5	25.00	17.25	33.5*	19.25	29.20	-	24	26.19	2325	2200
20	19.25	4.0	36.0	36.5	27.50	19.25	35.5*	20.81	32.27	-	18	27.75	3310	2760
22	21.25	4.0	40.0	40.5	29.50	21.25	38.5*	22.28	36.00	-	18	29.22	3875	3510
24	23.25	4.0	42.0	42.5	32.00	23.25	42.0*	23.69	38.76	-	18	30.63	4620	4260
26	25.00	5.0	45.0	-	34.25	25.00	44.5*	26.49	41.75	-	24	34.34	6400	5600
28	27.00	5.0	49.0	-	36.50	27.00	47.0*	27.88	44.86	-	24	35.72	7200	6500
30	29.00	5.0	51.0	-	38.75	29.00	49.0*	29.51	47.90	-	24	37.37	9500	8800
34	32.75	5.0	58.0	-	43.75	32.75	54.5*	32.16	53.64	-	30	40.01	13500	12000
36	34.50	5.0	60.0	-	46.00	34.50	56.5*	33.76	56.83	-	36	41.60	15150	14500
40	38.50	7.5	69.0	-	50.75	38.50	65.0*	40.14	65.00	-	30	50.25	-	-
42	41.25	7.5	72.0	-	53.00	41.25	66.5*	41.78	68.60	-	42	51.89	-	-
48	46.50	7.5	80.0	-	59.50	46.50	76.0*	45.90	77.00	-	-	-	-	-
SIZE mm													kg	
50	52	25	178	191	152	52	279□	100	127	610	-	161	18	20
80	80	25	203	216	191	80	318□	130	171	610	-	189	28	34
100	103	38	229	241	229	103	356	151	216	914	-	214	52	45
150	152	38	394	406	279	152	457	201	286	914	-	265	91	102
200	203	51	457	470	343	203	546□	254	394	-	457	319	194	204
250	254	51	533	546	406	254	597□	308	470	-	457	369	320	295
300	305	76	610	622	483	305	673□	368	568	-	457	512	549	499
350	337	76	686	699	533	337	724*	372	610	-	610	537	603	558
400	387	76	762	775	597	387	775*	407	669	-	610	572	748	703
450	438	102	864	876	635	438	851	489	742	-	610	665	1055	998
500	489	102	914	927	699	489	902	529	820	-	457	705	1501	1252
550	540	102	1016	1029	749	540	978*	566	914	-	457	742	1758	1592
600	591	102	1067	1080	813	591	1067*	602	985	-	457	778	2096	1932
650	635	127	1143	-	870	635	1130*	673	1060	-	610	872	2903	2540
700	686	127	1245	-	927	686	1194*	708	1139	-	610	907	3266	2948
750	737	127	1295	-	984	737	1245*	750	1217	-	610	949	4309	3992
850	832	127	1473	-	1111	832	1384*	817	1362	-	762	1016	6123	5443
900	876	127	1524	-	1168	876	1435*	858	1443	-	914	1057	6872	6577
1000	978	191	1753	-	1289	978	1651*	1020	1651	-	762	1276	-	-
1050	1048	191	1829	-	1346	1048	1689*	1061	1742	-	1067	1318	-	-
1200	1181	191	2032	-	1511	1181	1930*	1166	1956	-	-	-	-	-

+ Length (A) of a weld x flanged end valve is one half the sum of length (A) of a weld end and a flange end of the same size and rating.

* Short pattern.

□ Length exceeds specified dimensions in API 6D/ISO 14313.

† Dimensions of 22 in. (550 mm) flanges are per MSS-SP-44 and 26 in. (650 mm) through 42 in. (1050 mm) flanges are per ASME B16.47 Series A.

缩径 ASME/ANSI CLASS 150 (PN 20)

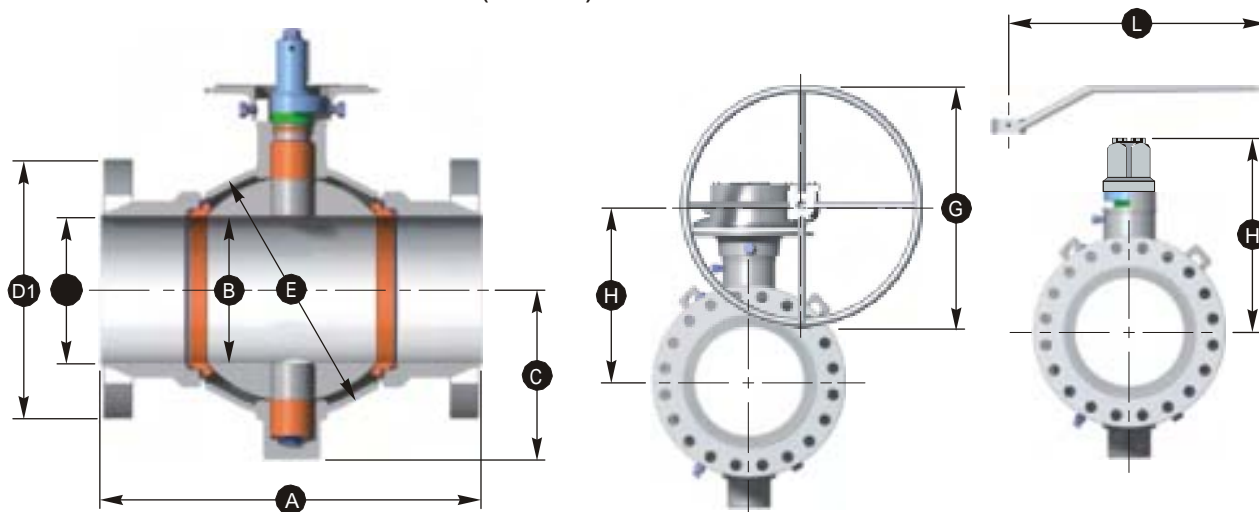

DIMENSIONS

SIZE in.	Ball Nom. Dia.	Bore	Stem Size	RF Length	RTJ Length	Dia. D1	Dia. D2	Weld End + Length A	C.L. to Bottom C	Body Sphere E	Lever Length L	Diameter Handwheel for Gear G	C.L. to Handwheel C.L. H	Valve Flange	Valve lb. Weld
3	2.06	1.0	8.0	8.5	7.50	3.13	11.0	□	3.94	5.00	24	-	6.34	55	50
4	3.13	1.0	9.0	9.5	9.00	4.06	12.5	□	5.12	6.75	24	-	7.44	100	87
6	4.06	1.5	15.5	16.0	11.00	6.00	14.0	□	5.94	8.50	36	-	8.43	170	150
8	6.00	1.5	18.0	18.5	13.50	8.00	18.0		7.91	11.25	36	-	10.43	345	
10	8.00	2.0	21.0	21.5	16.00	10.00	21.5	□	10.00	15.50	-	18	12.55	620	525
12	10.00	2.0	24.0	24.5	19.00	12.00	23.5	□	12.12	18.50	-	18	14.54	950	840
14	12.00	3.0	27.0	27.5	21.00	13.25	26.5	□	14.50	22.36	-	18	20.14	1280	1160
16	13.25	3.0	30.0	30.5	23.50	15.25	28.5*		14.64	24.00	-	24	21.16	1450	1330
18	15.25	3.0	34.0	34.5	25.00	17.25	30.5*		16.01	26.32	-	24	22.52	1510	1700
20	17.25	4.0	36.0	36.5	27.50	19.25	33.5*		19.25	29.20	-	24	26.19	2410	2300
22	19.25	4.0	40.0	40.5	29.50	21.25	35.5*		20.81	32.27	-	18	27.75	3450	3050
24	21.25	4.0	42.0	42.5	32.00	23.25	38.5*		22.28	36.00	-	18	29.22	4300	3650
26	23.25	4.0	45.0	-	34.25	25.00	42.0*		23.69	38.76	-	18	30.63	5400	5100
28	25.00	5.0	49.0	-	36.50	27.00	44.5*		26.49	41.75	-	24	34.34	7040	6100
30	27.00	5.0	51.0	-	38.75	29.00	47.0*		27.88	44.86	-	24	35.72	8900	7600
32	29.00	5.0	54.0	-	41.75	32.75	49.0*		29.51	47.90	-	24	37.37	9600	8500
36	32.75	5.0	60.0	-	46.00	34.50	54.5*		32.16	53.64	-	30	40.01	14000	12500
42	34.50	5.0	72.0	-	53.00	41.25	56.5*		33.76	56.83	-	36	41.60	-	-
SIZE mm															kg
80	52	25	203	216	191	80	279	□	100	127	610	-	161	25	23
100	80	25	229	241	229	103	318	□	130	172	610	-	189	45	39
150	103	38	394	406	279	152	356	□	151	216	914	-	214	77	68
200	152	38	457	470	343	203	457		201	286	914	-	265	156	132
250	203	51	533	546	406	254	564	□	254	394	-	457	319	281	238
300	254	51	610	622	483	305	597	□	308	470	-	457	369	431	381
350	305	76	686	699	533	337	673	□	368	568	-	457	512	581	526
400	337	76	762	775	597	387	724*		372	610	-	609	537	658	603
450	387	76	864	876	635	438	774*		407	669	-	609	572*	685	771
500	438	102	914	927	699	489	851*		489	741	-	609	665	1093	1043
550	489	102	1016	1029	749	540	902*		529	820	-	457	705	1565	1383
600	540	102	1067	1080	813	591	978*		566	914	-	457	742	1950	1656
650	591	102	1143	-	870	635	1067*		602	985	-	457	778	2449	2313
700	635	127	1245	-	927	686	1130*		673	1061	-	609	872	3193	2767
750	686	127	1295	-	984	737	1194*		708	1139	-	609	907	4037	3447
800	737	127	1372	-	1048	832	1245*		750	1217	-	609	949	4355	3856
900	832	127	1524	-	1168	876	1384*		817	1363	-	762	1016	6350	5670
1050	876	127	1829	-	1346	1048	1435*		858	1444	-	914	1057	-	-

+ Length (A) of a weld x flanged end valve is one half the sum of length (A) of a weld end and a flange end of the same size and rating.
* Short pattern.

□ Length exceeds specified dimensions in API 6D/ISO 14313.

! Dimensions of 22 in. (550 mm) flanges are per MSS SP 44 and 26 in. (650 mm) through 42 in. (1050 mm) flanges are per ASME B16.1 Series A

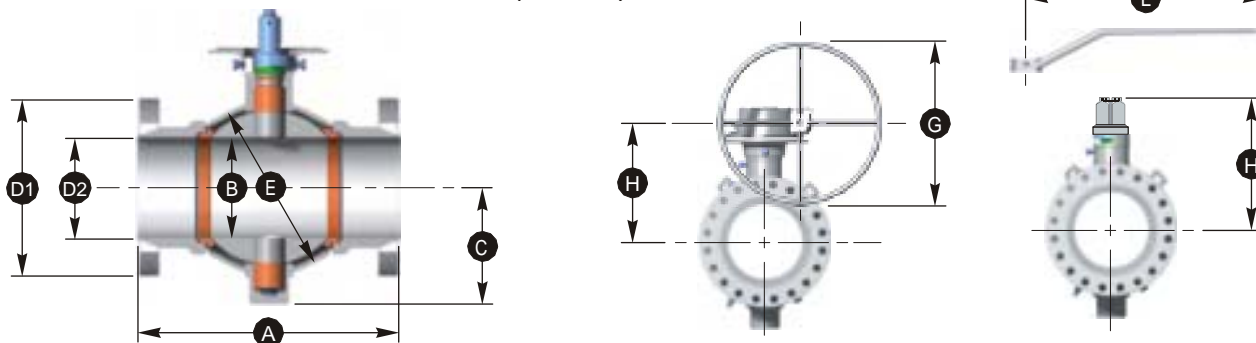

TC1455
12/04 NP-5M

全通径 ASME/ANSI CLASS 300 (PN 50)

DIMENSIONS

SIZE in.		Ball	RF		RTJ	Weld End +		C.L. to	Body	Lever	Diameter	C.L. to		Valve
Nom Dia.	Bore	Stem Size	Length A	Length A	Dia. D1	Dia. D2	Length A	Bottom C	Sphere E	Length L	Handwheel for Gear G	Handwheel C.L. H	Flange	Weld
2	2.06	1.0	8.50	9.125	6.50	2.06	11.0□	3.94	5.00	24	-	6.34	50	45
3	3.13	1.0	11.125	11.750	8.25	3.13	12.5□	5.12	6.75	24	-	7.44	80	75
4	4.06	1.5	12.00	12.625	10.00	4.06	14.0□	5.94	8.50	36	-	8.43	125	100
6	6.00	1.5	15.875	16.500	12.50	6.00	18.0	7.91	11.25	36	-	10.43	250	225
8	8.00	2.0	19.75**	20.375	15.00	8.00	21.5□	10.00	15.50	-	-	18	12.55	455
10	10.00	2.0	22.375	23.000	17.50	10.00	23.5□	12.12	18.50	-	24	14.54	750	650
12	12.00	3.0	25.50	26.125	20.50	12.00	26.5□	14.50	22.36	-	18	20.14	1275	1100
14	13.25	3.0	30.00	30.625	23.00	13.25	28.5*	14.64	24.00	-	24	21.16	1370	1230
16	15.25	3.0	33.00	33.625	25.50	15.25	30.5*	16.01	26.32	-	24	22.52	1725	1550
18	17.25	4.0	36.00	36.625	28.00	17.25	33.5*	19.25	29.20	-	24	26.19	2700	2200
20	19.25	4.0	39.00	39.750	30.50	19.25	35.5*	20.81	32.27	-	18	27.75	3400	2760
22	21.25	4.0	43.00	43.875	33.00	21.25	38.5*	22.28	36.00	-	24	29.22	4050	3510
24	23.25	4.0	45.00	45.875	36.00	23.25	42.0*	23.69	38.76	-	24	30.63	5390	4260
26	25.00	5.0	49.00	50.000	38.25	25.00	44.5*	26.49	41.75	-	24	34.34	6625	5600
28	27.00	5.0	53.00	54.000	40.75	27.00	47.0*	27.88	44.86	-	24	35.72	7725	6500
30	29.00	5.0	55.00	56.000	43.00	29.00	49.0*	29.51	47.90	-	30	37.37	10000	8800
34	32.75	5.0	64.00	65.125	47.50	32.75	54.5*	32.16	53.64	-	36	40.01	14700	12000
36	34.50	7.5	68.00	69.125	50.00	34.50	56.5*	36.80	56.83	-	24	46.92	16300	15500
40	38.50	7.5	74.00	-	48.75	38.50	65.0*	40.14	65.00	-	36	50.25	-	-
42	41.25	7.5	76.00	-	50.75	41.25	66.5*	41.78	68.60	-	42	51.89	-	-
48	46.50	7.5	86.00	-	57.75	46.50	76.0*	45.90	77.00	-	-	-	-	-
SIZE mm														kg
50	52	25	216	232	165	52	279□	100	127	610	-	161	23	20
80	80	25	283	298	210	80	318□	130	172	610	-	189	36	34
100	103	38	305	321	254	103	356□	151	216	914	-	214	57	45
150	152	38	403	419	318	152	457	201	286	914	-	265	113	102
200	203	51	502**	518	381	203	546□	254	394	-	457	319	206	204
250	254	51	568	584	445	254	597□	308	470	-	610	369	340	295
300	305	76	648	664	521	305	673□	368	568	-	457	512	578	499
350	337	76	762	778	584	337	724*	372	610	-	610	537	621	558
400	387	76	838	854	648	387	775*	407	669	-	610	572	782	703
450	438	102	914	930	711	438	851*	489	742	-	610	665	1225	998
500	489	102	991	1010	775	489	902*	529	820	-	457	705	1542	1252
550	540	102	1092	1114	838	540	978*	566	914	-	610	742	1837	1592
600	591	102	1143	1165	914	591	1067*	602	985	-	609	778	2445	1932
650	635	127	1245	1270	972	635	1130*	673	1060	-	610	872	3005	2540
700	686	127	1346	1372	1035	686	1194*	708	1139	-	610	907	3504	2948
750	737	127	1397	1422	1092	737	1245*	750	1217	-	762	949	4536	3992
850	832	127	1626	1654	1207	832	1384*	817	1362	-	914	1016	6668	5443
900	876	191	1727	1756	1270	876	1435*	935	1443	-	610	1192	7394	7031
1000	978	191	1880	-	1238	978	1651*	1020	1651	-	914	1276	-	-
1050	1048	191	1930	-	1289	1048	1689*	1061	1742	-	1067	1318	-	-
1200	1181	191	2184	-	1467	1181	1930*	1166	1956	-	-	-	-	-

+ Length (A) of a weld x flanged end valve is one half the sum of length (A) of a weld end and a flanged end of the same size and rating.

* Short pattern.

□ Length exceeds specified dimensions in API 6D/ISO 14313.

† Dimensions of 22 in. (650 mm) flanges are per MSS-SP-44 and 26 in. (650 mm) through 42 in. (1050 mm) flanges are per ASME B16.47 Series A.

** Prior to 1/1/98 - manufactured to 16.5 in. (419 mm) short pattern length.

缩径 ASME/ANSI CLASS 300 (PN 50)

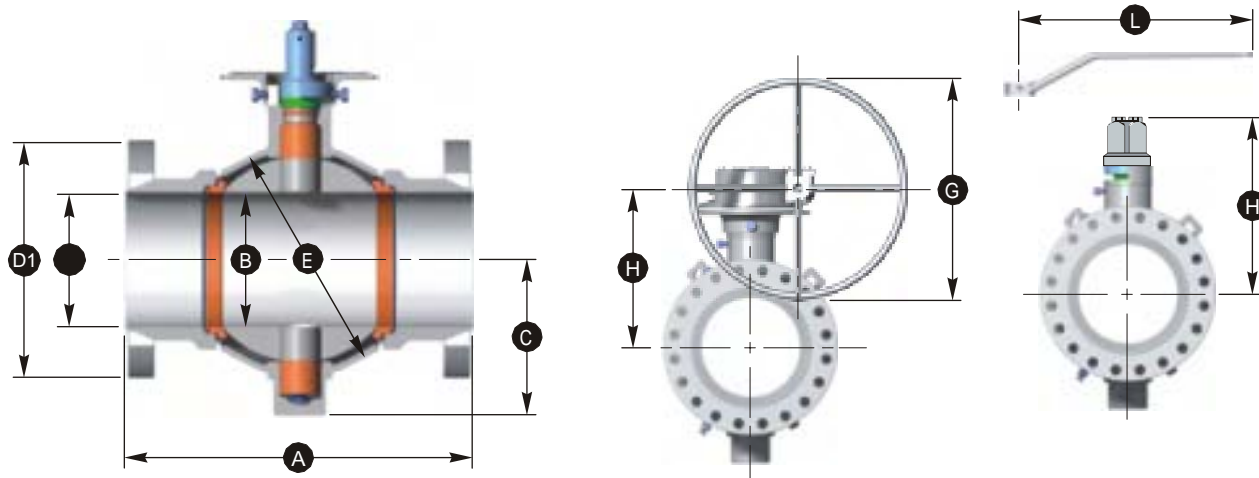

DIMENSIONS

SIZE in.	Ball Bgre	Stem Size	RF Length	RTJ Length	Dia. D1	Dia. D2	Weld End + Length A	C.L. to Bottom C	Body Sphere E	Lever Length L	Diameter Handwheel for Gear G	C.L. to Handwheel C.L. H	Valve lb. Flange	Valve lb. Weld
3	2.06	1.0	11.125	11.75	8.25	3.13	11.0*	3.94	5.00	24	-	6.34	64	50
4	3.13	1.0	12.00	12.625	10.00	4.06	12.5□	5.12	6.75	24	-	7.44	95	87
6	4.06	1.5	15.875	16.500	12.50	6.00	14.0*	5.94	8.50	36	-	8.43	180	150
8	6.00	1.5	19.75**	20.375	15.00	8.00	18.0*	7.91	11.25	36	-	10.43	365	-
10	8.00	2.0	22.375	23.000	17.50	10.00	21.5*	10.00	15.50	-	18	12.55	650	525
12	10.00	2.0	25.50	26.125	20.50	12.00	23.5*	12.12	18.50	-	24	14.54	1050	840
14	12.00	3.0	30.00	30.625	23.00	13.25	26.5*	14.50	22.36	-	18	20.14	1285	1160
16	13.25	3.0	33.00	33.625	25.50	15.25	28.5*	14.64	24.00	-	24	21.16	1660	1330
18	15.25	3.0	36.00	36.625	28.00	17.25	30.5*	16.01	26.32	-	24	22.52	1990	1700
20	17.25	4.0	39.00	39.750	30.50	19.25	33.5*	19.25	29.20	-	24	26.19	3100	2300
22	19.25	4.0	43.00	43.875	33.00	21.25	33.5*	20.81	32.27	-	18	27.75	3600	3050
24	21.25	4.0	45.00	45.875	36.00	23.25	38.5*	22.28	36.00	-	24	29.22	4500	3650
26	23.25	4.0	49.00	50.000	38.25	25.00	42.0*	23.69	38.76	-	24	30.63	5750	5100
28	25.00	5.0	53.00	54.000	40.75	27.00	44.5*	26.49	41.75	-	24	34.34	7260	6100
30	27.00	5.0	55.00	56.000	43.00	29.00	47.0*	27.88	44.86	-	24	35.72	9100	7600
32	29.00	5.0	60.00	61.125	45.25	32.75	49.0*	29.51	47.90	-	30	37.37	10150	8800
36	32.75	5.0	68.00	69.125	50.00	34.50	54.5*	32.16	53.64	-	36	40.01	15350	13000
42	34.50	7.5	76.00	-	50.75	41.25	56.5*	36.80	56.83	-	24	49.92	-	-
SIZE mm													kg	
80	52	25	283	298	210	80	279*	100	127	610	-	161	29	23
100	80	25	305	321	254	103	318□	130	171	610	-	189	43	39
150	103	38	403	419	318	152	356*	151	216	914	-	214	82	68
200	152	38	502**	518	381	203	457*	201	286	914	-	265	166	132
250	203	51	568	584	445	254	546*	254	394	-	457	319	295	238
300	254	51	648	664	521	305	597*	308	470	-	610	369	476	381
350	305	76	762	778	584	337	673*	368	568	-	457	512	583	526
400	337	76	838	854	648	387	724*	372	610	-	610	537	753	603
450	387	76	914	930	711	438	775*	407	669	-	610	572	903	771
500	438	102	991	1010	775	489	851*	489	742	-	610	665	1406	1043
550	489	102	1092	1114	838	540	851*	529	820	-	457	705	1633	1383
600	540	102	1143	1165	914	591	978*	566	914	-	610	742	2041	1656
650	591	102	1245	1270	972	635	1067*	602	985	-	610	778	2608	2313
700	635	127	1346	1372	1035	686	1130*	673	1060	-	610	872	3293	2767
750	686	127	1397	1422	1092	737	1194*	708	1139	-	610	907	4128	3447
800	737	127	1524	1553	1149	832	1245*	750	1217	-	762	949	4604	3992
900	832	127	1727	1756	1270	867	1384*	817	1362	-	914	1016	6963	5897
1050	876	191	1930	-	1289	1048	1435*	935	1443	-	610	1192	-	-

+ Length (A) of a weld x flanged end valve is one half the sum of length (A) of a weld end and a flange end of the same size and rating.
* Short pattern.

□ Length exceeds specified dimensions in API 6D/ISO 14313.
▮ Dimensions of 22 in. (650 mm) flanges are per MSS-SP-44 and 26 in. (650 mm) through 42 in. (1050 mm) flanges are per ASME B16.47 Series A.

** Prior to 1/1/98 - manufactured to 16.5 in. (419 mm) short pattern length.

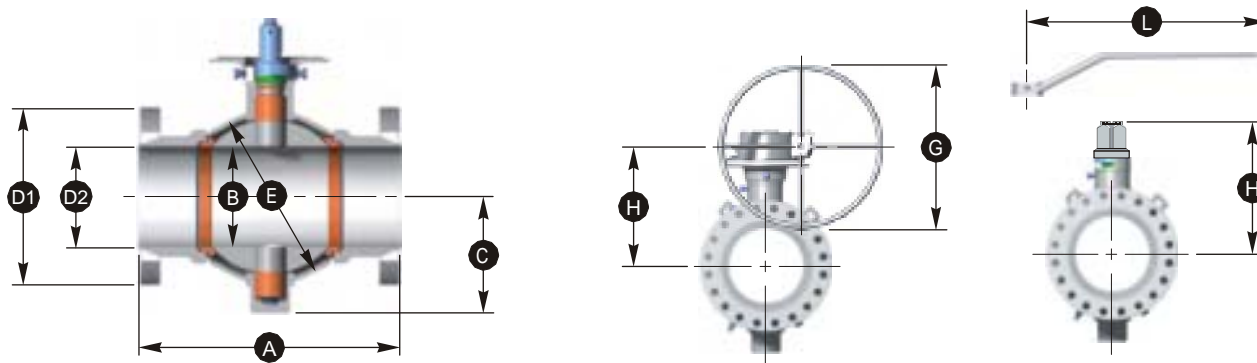
全通径 ASME/ANSI CLASS 400 (PN 64)

DIMENSIONS

SIZE in.	Ball Bore	RF Stem Size	RF Length	RTJ Length	Flange Dia.	Body Dia.	Weld End + Length A	C.L. to Bottom C	Body Sphere E	Lever Length L	Diameter Handwheel for Gear G	C.L. to Handwheel C.L. H	Valve lb. Flange	Valve lb. Weld	
2	2.06	Use ASME/ANSI Class 600 Valves (PN 100)													
3	3.13	Use ASME/ANSI Class 600 Valves (PN 100)													
4	4.06	1.5	16.0	16.125	10.00	4.06	14.0*	5.94	8.50	36	-	8.43	150	100	
6	6.00	1.5	19.5	19.625	12.50	6.00	18.0*	7.91	11.25	36	-	10.43	300	225	
8	8.00	2.0	23.5	23.625	15.00	8.00	21.5*	10.00	15.50	-	18	12.55	550	450	
10	10.00	2.0	26.5	26.625	17.50	10.00	23.5*	12.12	18.50	-	24	14.54	850	650	
12	12.00	3.0	30.0	30.125	20.50	12.00	26.5*	14.50	22.36	-	18	20.14	1400	1100	
14	13.25	3.0	32.5	32.625	23.00	13.25	28.5*	14.64	24.00	-	18	21.16	1650	1230	
16	15.25	4.0	35.5	35.625	25.50	15.25	30.5*	17.84	26.32	-	18	24.78	2225	1770	
18	17.25	4.0	38.5	38.625	28.00	17.25	33.5*	19.25	29.20	-	24	26.19	2850	2200	
20	19.25	5.0	41.5	41.750	30.50	19.25	35.5*	22.11	32.27	-	24	30.00	3750	3000	
22	21.25	5.0	45.0	45.375	33.00	21.25	38.5*	23.63	36.00	-	24	31.53	4750	3950	
24	23.25	5.0	48.5	48.875	36.00	23.25	42.0*	25.05	38.76	-	24	32.95	5600	4750	
26	25.00	5.0	51.5	52.000	38.25	25.00	44.5*	26.49	41.75	-	24	34.34	7100	5600	
28	27.00	5.0	55.0	55.500	40.75	27.00	47.0*	27.88	44.86	-	30	35.72	8560	6500	
30	29.00	5.0	60.0	60.500	43.00	29.00	49.0*	29.51	47.90	-	36	37.37	10600	8800	
34	32.75	7.5	70.0	70.625	47.50	32.75	54.5*	35.19	53.64	-	30	45.31	15400	12300	
36	34.50	7.5	74.0	74.625	50.00	34.50	56.5*	36.80	56.83	-	30	46.92	18000	15500	
40	38.50	7.5	78.0	-	50.00	38.50	65.0*	40.14	65.00	-	42	50.25	25500	22250	
42	41.25	7.5	81.0	-	52.00	41.25	66.5*	41.78	68.60	-	42	51.89	28750	24750	
48	46.50	9.0	91.0	-	59.50	46.50	76.0*	47.98	77.00	-	-	-	-	-	
SIZE mm														kg	
50	52	Use ASME/ANSI Class 600 Valves (PN 100)													
80	80	Use ASME/ANSI Class 600 Valves (PN 100)													
100	103	38	406	410	254	103	356*	151	216	914	-	214	68	45	
150	152	38	495	498	318	152	457*	201	286	914	-	265	136	102	
200	203	51	597	600	381	203	546*	254	394	-	457	319	249	204	
250	254	51	673	676	445	254	597*	308	470	-	610	369	386	295	
300	305	76	762	765	521	305	673*	368	568	-	457	512	635	499	
350	337	76	826	829	584	337	724*	372	610	-	457	537	748	558	
400	387	102	902	905	648	387	775*	453	669	-	457	629	1009	803	
450	438	102	978	981	711	438	851*	489	742	-	610	665	1293	998	
500	489	127	1054	1060	775	489	902*	562	820	-	610	762	1701	1361	
550	540	127	1143	1153	838	540	978*	600	914	-	610	801	2155	1792	
600	591	127	1232	1241	914	591	1067*	636	985	-	610	837	2540	2155	
650	635	127	1308	1321	971.2	635	1130*	673	1060	-	610	872	3221	2540	
700	686	127	1397	1410	1035	686	1194*	708	1139	-	762	907	3883	2948	
750	737	127	1524	1537	1092	737	1245*	750	1217	-	914	949	4808	3992	
850	832	191	1778	1794	1207	832	1384*	894	1362	-	762	1151	6985	5579	
900	876	191	1880	1895	1270	876	1435*	935	1443	-	762	1192	8165	7031	
1000	978	191	1981	-	1270	978	1651*	1020	1651	-	1067	1276	11567	10092	
1050	1048	191	2057	-	1321	1048	1689*	1061	1742	-	1067	1318	13041	11226	
1200	1181	229	2311	-	1511	1181	1930*	1219	1956	-	-	-	-	-	

+ Length (A) of a weld x flanged end valve is one half the sum of length (A) of a weld end and a flange end of the same size and rating.

* Short pattern.

! Dimensions of 22 in. (550 mm) flanges are per MSS-SP-44 and 26 in. (650 mm) through 42 in. (1050 mm) flanges are per ASME B16.47 Series A.

缩径 ASME/ANSI CLASS 400 (PN 64)

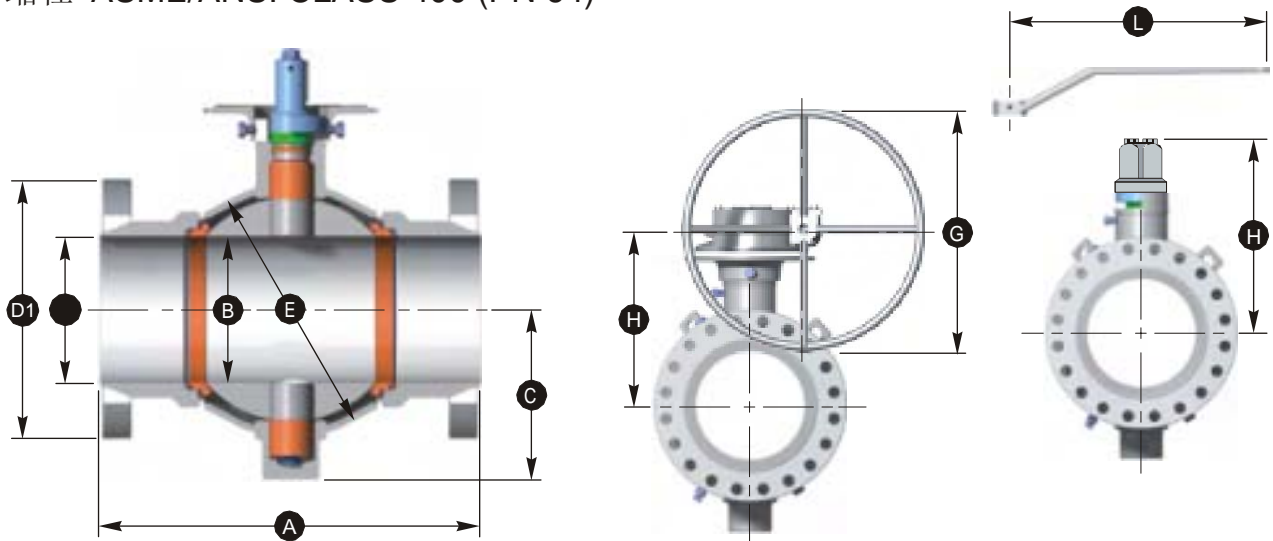

DIMENSIONS

SIZE in.	Ball Bgre	RF Stem Size	RTJ Length	RTJ Length A	Dia. D1	Dia. D2	Weld End + Length A	C.L. to Bottom C	Body Sphere E	Lever Length L	Diameter Handwheel for Gear G	C.L. to Handwheel C.L. H	Valve lb. Flange	Valve lb. Weld	
3	2.06	Use ASME/ANSI Class 600 Valves (PN 100)													
4	3.13	1.0	16.0	16.125	10.00	4.06	12.5*	5.12	6.75	24	-	7.44	125	87	
6	4.06	1.5	19.5	19.625	12.50	6.00	14.0*	5.94	8.50	36	-	8.43	189	150	
8	6.00	1.5	23.5	23.625	15.00	8.00	18.0*	7.91	11.25	-	18	10.43	424	290	
10	8.00	2.0	26.5	26.625	17.50	10.00	21.5*	10.00	15.50	-	18	12.55	608	525	
12	10.00	2.0	30.0	30.125	20.50	12.00	23.5*	12.12	18.50	-	24	14.54	1020	840	
14	12.00	3.0	32.5	32.625	23.00	13.25	26.5*	14.50	22.36	-	18	20.14	1490	1160	
16	13.25	3.0	35.5	35.625	25.25	15.25	28.5*	14.64	24.00	-	18	21.16	1910	1330	
18	15.25	4.0	38.5	38.625	28.00	17.25	30.5*	17.84	36.32	-	18	24.78	2400	1920	
20	17.25	4.0	41.5	41.750	30.50	19.25	33.5*	19.25	29.20	-	24	26.19	3200	2650	
22	19.25	5.0	45.0	45.375	33.00	21.25	35.5*	22.11	32.27	-	24	30.00	4250	3300	
24	21.25	5.0	48.5	48.875	36.00	23.25	38.5*	23.63	36.00	-	24	31.53	5050	4300	
26	23.25	5.0	51.5	52.000	38.25	25.00	42.0*	25.05	38.76	-	24	32.95	6250	5100	
28	25.00	5.0	55.0	55.500	40.75	27.00	44.5*	26.49	41.75	-	24	34.34	7750	6100	
30	27.00	5.0	60.0	60.500	43.00	29.00	47.0*	27.88	44.86	-	30	35.72	9500	7600	
32	29.00	5.0	65.0	65.625	45.25	32.75	49.0*	29.51	47.90	-	36	37.37	11500	9350	
36	32.75	7.5	74.0	74.625	50.00	34.50	54.5*	35.19	53.64	-	30	45.31	16000	13000	
42	34.50	7.5	81.0	-	52.00	41.25	56.5*	36.80	56.83	-	30	46.92	-	-	
SIZE mm														kg	
80	52	Use ASME/ANSI Class 600 Valves (PN 100)													
100	80	25	406	410	254	103	318*	130	171	610	-	189	57	39	
150	103	38	495	498	318	152	356*	151	216	914	-	214	86	68	
200	152	38	597	600	381	203	457*	201	286	-	457	265	192	132	
250	203	51	673	676	445	254	546*	254	394	-	457	319	276	238	
300	254	51	762	765	521	305	597*	308	470	-	610	369	463	381	
350	305	76	826	829	584	337	673*	368	568	-	457	512	676	526	
400	337	76	902	905	641	387	724*	372	610	-	457	537	866	603	
450	387	102	978	981	711	438	775*	453	923	-	457	629	1089	871	
500	438	102	1054	1060	775	489	851*	489	742	-	610	665	1451	1202	
550	489	127	1143	1153	838	540	902*	562	820	-	610	762	1928	1497	
600	540	127	1232	1241	914	591	978*	600	914	-	610	801	2291	1950	
650	591	127	1308	1321	972	635	1067*	636	985	-	610	837	2835	2313	
700	635	127	1397	1410	1035	686	1130*	673	1060	-	610	872	3515	2767	
750	686	127	1524	1537	1092	737	1194*	708	1139	-	762	907	4309	3447	
800	737	127	1651	1667	1149	832	1245*	750	1217	-	914	949	5216	4241	
900	832	191	1880	1895	1270	876	1384*	894	1362	-	762	1151	7257	5897	
1050	876	191	2057	-	1321	1048	1435*	935	1443	-	762	1192	-	-	

+ Length (A) of a weld x flanged end valve is one half the sum of length (A) of a weld end and a flange end of the same size and rating.

* Short pattern.

! Dimensions of 22 in. (550 mm) flanges are per MSS-SP-44 and 26 in. (650 mm) through 42 in. (1050 mm) flanges are per ASME B16.47 Series A.



TC1455
12/04 NP-5M

15

口径 ASME/ANSI CLASS 600 (PN 100)

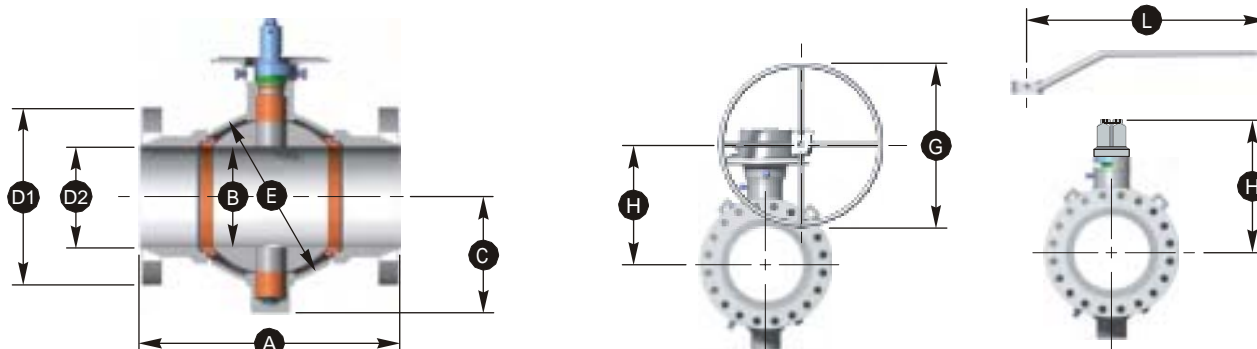
DIMENSIONS

SIZE in.		Ball Bore Size	RF		RTJ		Weld End + Length A	C.L. to Bottom C	Body Sphere E	Lever Length L	Diameter Handwheel for Gear G	C.L. to Handwheel C.L. H		Valve lb.	
Nom Dia.	Stem		Length	Length	Dia.	Dia. D2						Flange	Weld		
2	2.06	1.0	11.5	11.625	6.50	2.06	11.0*	3.94	5.00	24	-	6.34	60	45	
3	3.13	1.0	14.0	14.125	8.25	3.13	12.5*	5.12	6.75	24	-	7.44	85	75	
4	4.06	1.5	17.0	17.125	10.75	4.06	14.0*	5.94	8.50	36	-	8.43	165	100	
6	6.00	1.5	22.0	22.125	14.00	6.00	18.0*	7.91	11.25	36	-	10.43	360	225	
8	8.00	2.0	26.0	26.125	16.50	8.00	21.5*	10.00	15.50	-	24	12.55	650	450	
10	10.00	2.0	31.0	31.125	20.00	10.00	23.5*	12.12	18.50	-	30	14.54	1000	650	
12	12.00	3.0	33.0	33.125	22.00	12.00	26.5*	14.50	22.36	-	18	20.14	1510	1100	
14	13.25	3.0	35.0	35.125	23.75	13.25	28.5*	14.64	24.00	-	24	21.16	1910	1230	
16	15.25	4.0	39.0	39.125	27.00	15.25	30.5*	17.84	26.32	-	18	24.78	2400	1770	
18	17.25	4.0	43.0	43.125	29.25	17.25	33.5*	19.25	29.20	-	24	26.19	2955	2200	
20	19.25	5.0	47.0	47.250	32.00	19.25	35.5*	22.11	32.27	-	24	30.00	4100	3000	
22	21.25	5.0	51.0	51.375	34.25	21.25	38.5*	23.63	36.00	-	24	31.53	5400	3950	
24	23.25	5.0	55.0	55.375	37.00	23.25	42.0*	25.05	38.76	-	30	32.95	6550	4750	
26	25.00	5.0	57.0	57.500	40.00	25.00	44.5*	26.49	41.75	-	36	34.34	7800	5600	
28	27.00	7.5	61.0	61.500	42.25	27.00	47.0*	30.87	44.86	-	30	40.99	9500	6700	
30	29.00	7.5	65.0	65.500	44.50	29.00	49.0*	32.53	47.90	-	30	42.65	12000	9120	
34	32.75	7.5	76.0	76.625	49.00	32.75	54.5*	35.19	53.64	-	42	45.31	16025	12300	
36	34.50	7.5	82.0	82.625	51.75	34.50	56.5*	36.80	56.83	-	42	46.92	19100	15500	
40	38.50	9.0	80.0	-	52.00	38.50	65.0*	42.02	65.00	-	42	55.425	26770	23000	
42	41.25	9.0	83.0	-	55.25	41.25	66.5*	43.66	68.60	-	42	57.06	30500	25500	
48	46.50	11.0	94.0	-	62.75	46.50	76.0*	51.18	77.33	-	-	-	-	-	
SIZE mm												kg			
50	52	25	292	295	165	52	279*	100	127	610	-	161	27	20	
80	80	25	356	359	210	80	318*	130	171	610	-	189	39	34	
100	103	38	432	435	273	103	356*	151	216	914	-	214	75	45	
150	152	38	559	562	356	152	457*	201	286	914	-	265	163	102	
200	203	51	660	664	419	203	546*	254	394	-	610	319	295	204	
250	254	51	787	791	508	254	597*	308	470	-	762	369	454	295	
300	305	76	838	841	559	304	673*	368	568	-	457	512	685	499	
350	337	76	889	892	603	337	724*	372	610	-	610	537	866	558	
400	387	102	991	994	686	387	775*	453	669	-	457	629	1089	803	
450	438	102	1092	1095	743	438	851*	489	742	-	610	665	1340	998	
500	489	127	1194	1200	813	489	902*	562	820	-	610	762	1860	1361	
550	540	127	1295	1305	870	540	978*	600	914	-	610	801	2449	1792	
600	591	127	1397	1407	940	591	1067*	636	985	-	762	837	2971	2155	
650	635	127	1448	1461	1016	635	1130*	673	1060	-	914	872	3538	2540	
700	686	191	1549	1562	1073	686	1194*	784	1139	-	762	1041	4309	3039	
750	737	191	1651	1664	1130	737	1245*	826	1217	-	762	1083	5443	4137	
850	832	191	1930	1946	1245	832	1384*	894	1362	-	1067	1151	7269	5579	
900	876	191	2083	2099	1314	876	1435*	935	1443	-	1067	1192	8664	7031	
1000	978	229	2032	-	1321	978	1651*	1067	1651	-	1067	1408	12143	10433	
1050	1048	229	2108	-	1403	1048	1689*	1109	1742	-	1067	1449	13835	11567	
1200	1181	279	2388	-	1594	1181	1930*	1300	1964	-	-	-	-	-	

+ Length (A) of a weld x flanged end valve is one half the sum of length (A) of a weld end and a flange end of the same size and rating.

* Short pattern.

! Dimensions of 22 in. (550 mm) flanges are per MSS-SP-44 and 26 in. (650 mm) through 42 in. (1050 mm) flanges are per ASME B16.47 Series A.

缩径 ASME/ANSI CLASS 600 (PN 100)

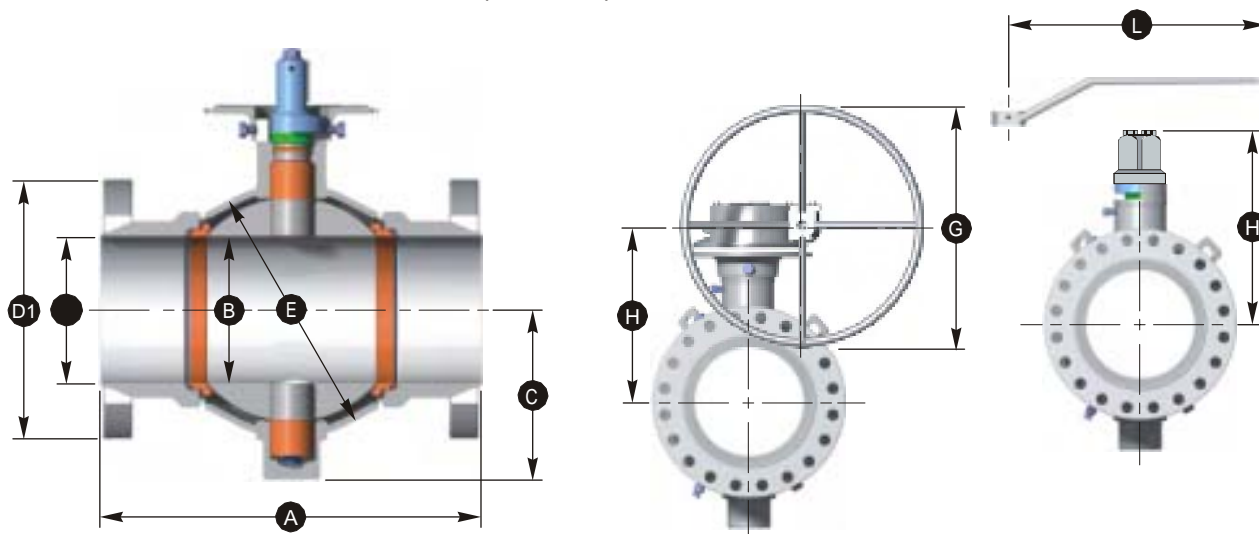

DIMENSIONS

SIZE in.	Ball B _{gr}	Stem Size	RF Length	RTJ Length	Dia. D1	Dia. D2	Weld End + Length A	C.L. to Bottom C	Body Sphere E	Lever Length L	Diameter Handwheel for Gear G	C.L. to Handwheel C.L. H	Valve lb. Flange	Valve lb. Weld
3	2.06	1.0	14	14.125	8.25	3.13	11.0*	3.94	5.00	24	-	6.34	80	50
4	3.13	1.0	17	17.125	10.75	4.06	12.5*	5.12	6.75	24	-	7.44	150	87
6	4.06	1.5	22	22.125	14.00	6.00	14.0*	5.94	8.50	36	-	8.43	250	150
8	6.00	1.5	26	26.125	16.50	8.00	18.0*	7.91	11.25	36	-	10.43	470	290
10	8.00	2.0	31	31.125	20.00	10.00	21.5*	10.00	15.50	-	24	12.55	850	525
12	10.00	2.0	33	33.125	22.00	12.00	23.5*	12.12	18.50	-	30	14.54	1150	840
14	12.00	3.0	35	35.125	23.75	13.25	26.5*	14.50	22.36	-	18	20.14	1640	1160
16	13.25	3.0	39	39.125	27.00	15.25	28.5*	14.64	24.00	-	24	21.16	2225	1330
18	15.25	4.0	43	43.125	29.25	17.25	30.5*	17.84	26.32	-	18	24.78	2600	1920
20	17.25	4.0	47	47.250	32.00	19.25	33.5*	19.25	29.20	-	24	26.19	3500	2650
22	19.25	5.0	51	51.375	34.25	21.25	35.5*	22.11	32.27	-	24	30.00	4450	3300
24	21.25	5.0	55	55.375	37.00	23.25	38.5*	23.63	36.00	-	24	31.53	5750	4300
26	23.25	5.0	57	57.500	40.00	25.00	42.0*	25.05	38.76	-	30	32.95	7000	5100
28	25.00	5.0	61	61.500	42.25	27.00	44.5*	26.49	41.75	-	36	34.34	8600	6300
30	27.00	7.5	65	65.500	44.50	29.00	47.0*	30.87	44.86	-	30	40.99	10100	7800
32	29.00	7.5	70	70.625	47.00	32.75	49.0*	32.53	47.90	-	30	42.65	12800	9350
36	32.75	7.5	82	82.625	51.75	34.50	54.5*	35.19	53.64	-	42	45.31	17600	13000
42	34.50	7.5	83	-	55.25	41.25	56.5*	36.80	56.83	-	42	46.92	-	-
SIZE mm														kg
80	52	25	356	359	210	80	279*	100	127	610	-	161	36	23
100	80	25	432	435	273	103	318*	130	171	610	-	189	68	39
150	103	38	559	562	356	152	356*	151	216	914	-	214	113	68
200	152	38	660	664	419	203	457*	201	286	914	-	265	213	132
250	203	51	787	791	508	254	546*	254	394	-	610	319	386	238
300	254	51	838	841	559	305	597*	308	470	-	762	369	522	381
350	305	76	889	892	603	337	673*	368	568	-	457	512	744	526
400	337	76	991	994	686	387	724*	372	610	-	610	537	1009	603
450	387	102	1092	1095	743	438	775*	453	669	-	457	629	1179	871
500	438	102	1194	1200	813	489	851*	489	742	-	610	665	1588	1202
550	489	127	1295	1305	870	540	902*	562	820	-	610	762	2018	1497
600	540	127	1397	1407	940	591	978*	600	914	-	610	801	2608	1950
650	591	127	1448	1461	1016	635	1067*	636	985	-	762	837	3175	2313
700	635	127	1549	1562	1073	686	1130*	673	1060	-	914	872	3901	2858
750	686	191	1651	1664	1130	737	1194*	784	1139	-	762	1041	4581	3538
800	737	191	1778	1794	1194	832	1245*	826	1217	-	762	1083	5806	4241
900	832	191	2083	2099	1314	876	1384*	894	1362	-	1067	1151	7983	5897
1050	876	191	2108	-	1403	1048	1435*	935	1443	-	1067	1192	-	-

+ Length (A) of a weld x flanged end valve is one half the sum of length (A) of a weld end and a flange end of the same size and rating.

* Short pattern.

! Dimensions of 22 in. (550 mm) flanges are per MSS-SP-44 and 26 in. (650 mm) through 42 in. (1050 mm) flanges are per ASME B16.47 Series A.



TC1455
12/04 NP-5M

全通径 ASME/ANSI CLASS 900 (PN 150)

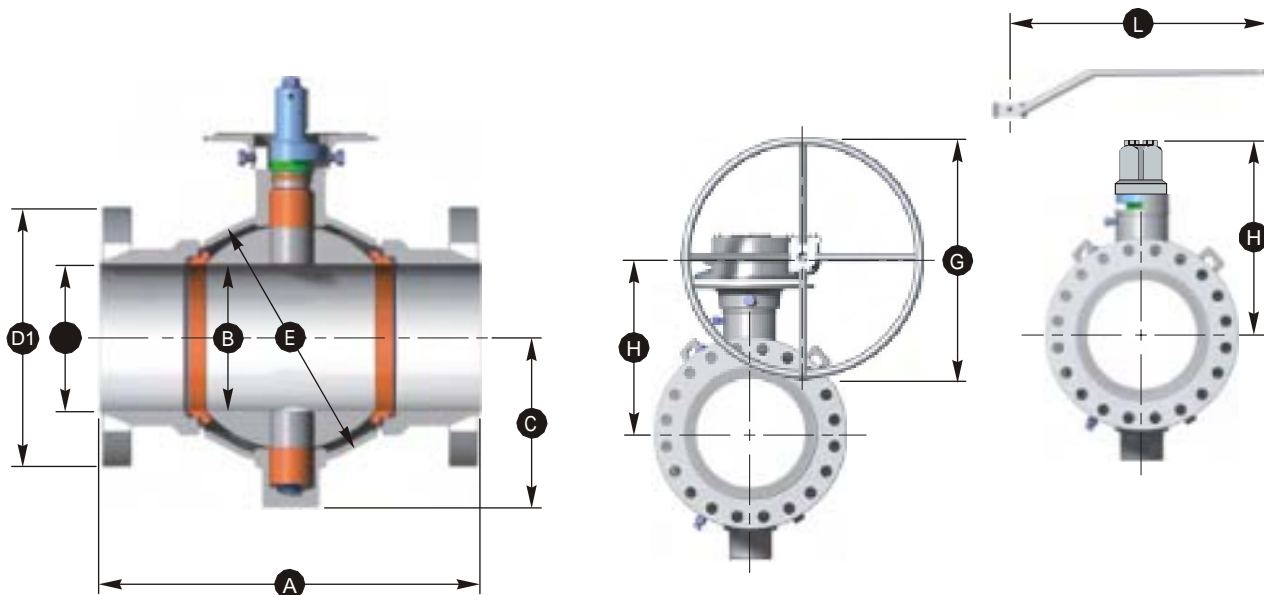

DIMENSIONS

SIZE in.	Ball Bore	Stem Size	RF Length	RTJ Length	Dia. D1	Dia. D2	Weld End + Length A	C.L. to Bottom C	Body Sphere E	Lever Length L	Diameter Handwheel for Gear G	C.L. to Handwheel C.L. H	Valve lb. Flange	Valve lb. Weld
2	2.06		Use 1500 Class Valves (PN 250)											
3	3.13	1.5	15.0	15.125	9.50	3.13	13.5*	4.88	7.00	36	-	7.44	140	120
4	4.06	2.0	18.0	18.125	11.50	4.06	15.0*	6.77	9.25	-	18	9.76	250	190
6	6.00	2.0	24.0	24.125	15.00	6.00	20.0*	8.39	12.50	-	24	10.86	525	410
8	8.00	2.0	29.0	29.125	18.50	8.00	23.5*	10.00	15.50	-	30	12.55	1210	590
10	10.00	3.0	33.0	33.125	21.50	10.00	25.5*	12.88	18.50	-	18	18.49	1325	1010
12	12.00	3.0	38.0	38.125	24.00	12.00	29.5*	14.50	22.36	-	24	20.14	2250	1350
14	12.75	5.0	40.5	40.875	25.25	12.75	31.5*	17.40	24.50	-	24	25.30	3250	2155
16	14.75	5.0	44.5	44.875	27.75	14.75	33.5*	19.02	27.25	-	24	26.92	4000	2450
18	16.75	5.0	48.0	48.500	31.00	16.75	36.5*	20.62	30.07	-	24	28.51	5300	3950
20	18.625	7.5	52.0	52.500	33.75	18.625	38.5*	24.22	33.88	-	24	35.23	7100	5250
24	22.50	7.5	61.0	61.750	41.00	22.50	45.0*	28.07	39.95	-	30	38.18	10500	6450
30	29.00	7.5	75.0	75.875	48.50	29.00	52.0*	32.53	49.88	-	42	42.65	17500	11500
36	34.50	9.0	90.0	91.125	57.50	34.50	59.5*	38.64	58.25	-	-	52.03	25600	17500
SIZE mm														kg
50	52		Use 1500 Class Valves (PN 250)											
30	80	38	381	384	241	80	343*	124	178	914	-	189	64	54
100	103	51	457	460	292	103	381*	172	235	-	457	248	113	86
150	152	51	610	613	381	152	508*	213	318	-	610	276	238	186
200	203	51	737	740	410	203	597*	254	394	-	762	319	549	268
250	254	76	838	841	546	254	648*	327	470	-	457	470	601	458
300	305	76	965	968	610	305	749*	368	568	-	610	512	1021	612
350	324	127	1029	1038	641	324	800*	442	622	-	610	643	1474	977
400	375	127	1130	1140	705	375	851*	483	692	-	610	684	1814	1111
450	425	127	1219	1232	787	425	927*	524	764	-	610	724	2404	1792
500	473	191	1321	1334	857	473	978*	615	861	-	610	895	3221	2381
600	572	191	1549	1568	1041	572	1143*	713	1015	-	762	970	4763	2926
750	737	191	1905	1927	1232	737	1321*	826	1267	-	1067	1083	7938	5216
900	876	229	2286	2315	1461	876	1511*	981	1480	-	-	1322	11612	7938

+ Length (A) of a weld x flanged end valve is one half the sum of length (A) of a weld end and a flange end of the same size and rating.

* Short pattern.
! Dimensions of 22 in. (550 mm) flanges are per MSS-SP-44 and 26 in. (650 mm) through 42 in. (1050 mm) flanges are per ASME B16.47 Series A.

缩径 ASME/ANSI CLASS 900 (PN 150)

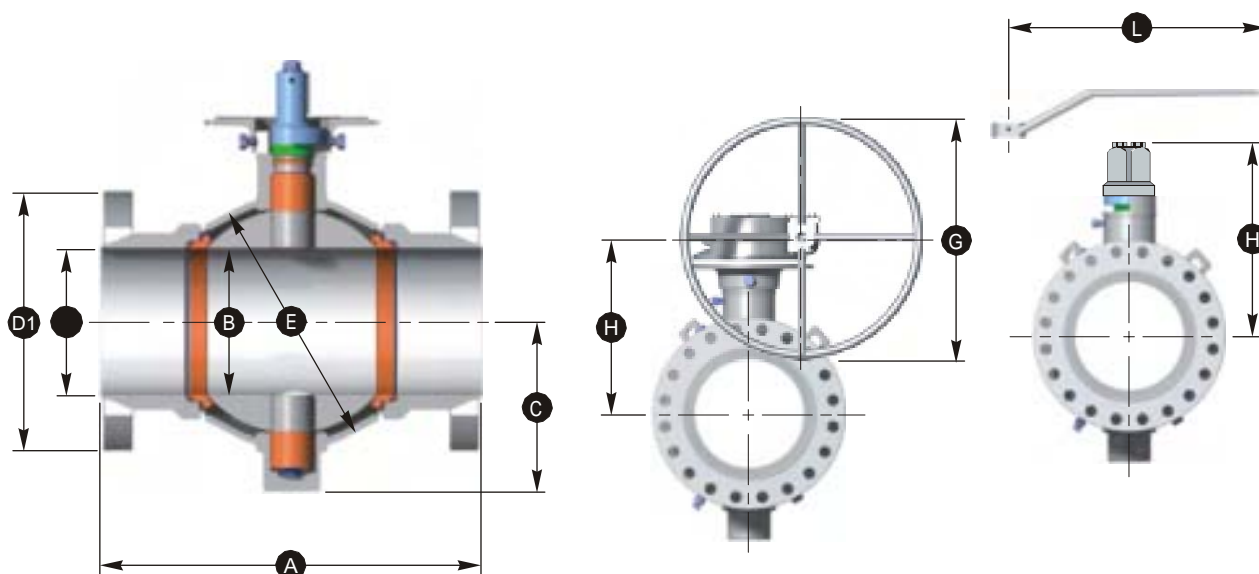

DIMENSIONS

SIZE in.	Ball	Stem	RF	RTJ	Diameter		Weld End +	C.L. to	Body	Lever	Diameter	C.L. to	Valve
Nom Dia.	Bore	Size	Length	Length	Dia. 1	Dia. D2	Length A	to Bottom C	Sphere E	Length L	Handwheel for Gear G	Handwheel C.L. H	Flange Weld
3	2.06	1.0	15.0	15.125	9.50	3.13	11.0*	3.94	5.00	24	-	6.34	120 70
4	3.13	1.5	18.0	18.125	11.50	4.06	13.5*	4.88	7.00	36	-	7.44	190 150
6	4.06	2.0	24.0	24.125	15.00	6.00	15.0*	6.77	9.25	-	18	9.76	400 260
8	6.00	2.0	29.0	29.125	18.50	8.00	20.0*	8.39	12.50	-	24	10.86	850 650
10	8.00	2.0	33.0	33.125	21.50	10.00	23.5*	10.00	15.50	-	30	12.55	1290 725
12	10.00	3.0	38.0	38.125	24.00	12.00	25.5*	12.88	18.50	-	18	18.49	1700 1110
14	12.00	3.0	40.5	40.875	25.25	12.75	29.5*	14.50	22.36	-	24	20.14	2750 1680
16	12.75	5.0	44.5	44.875	27.75	14.75	31.5*	17.40	24.50	-	24	25.30	3650 2300
SIZE mm													kg
80	52	25	381	384	241	80	279*	100	127	610	-	161	54 32
100	80	38	457	460	292	103	343*	124	178	914	-	189	86 68
150	103	51	610	613	381	152	381*	172	235	-	457	248	181 118
200	152	51	737	740	470	203	508*	213	318	-	610	276	386 295
250	203	51	838	841	546	254	597*	254	394	-	762	319	585 329
300	254	76	965	968	610	305	648*	327	470	-	457	470	771 503
350	305	76	1029	1038	641	324	749*	368	568	-	610	512	1247 762
400	324	127	1130	1140	705	375	800*	442	622	-	610	643	1656 1043

+ Length (A) of a weld x flanged end valve is one half the sum of length (A) of a weld end and a flange end of the same size and rating.

* Short pattern.

! Dimensions of 22 in. (550 mm) flanges are per MSS-SP-44 and 26 in. (650 mm) through 42 in. (1050 mm) flanges are per ASME B16.47 Series A.

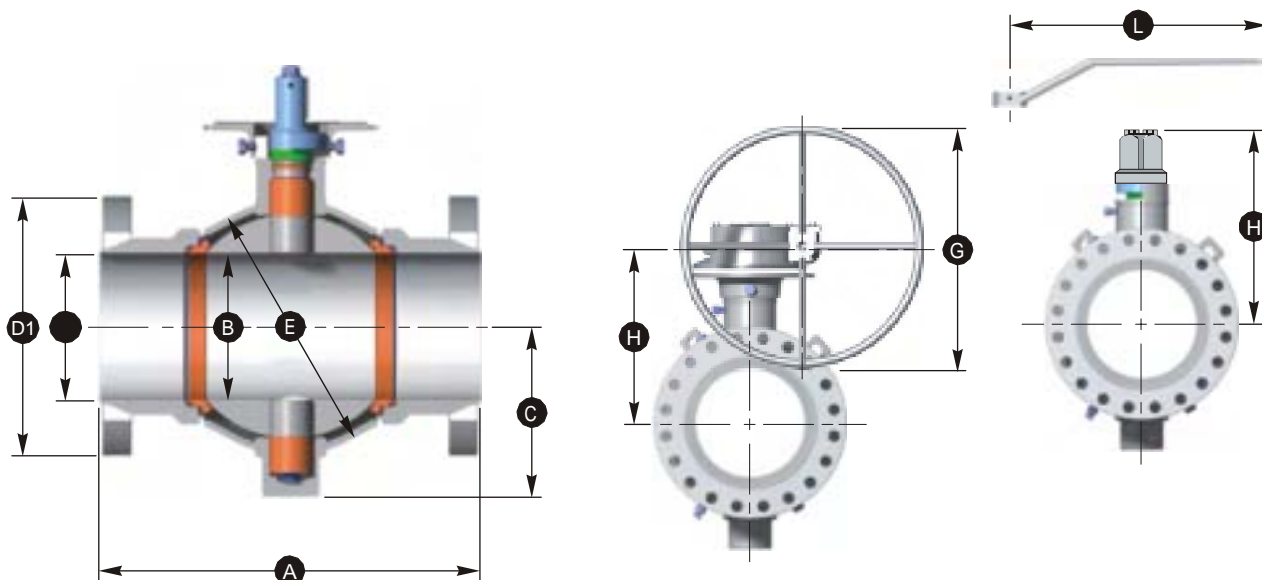

TC1455
12/04 NP-5M

全通径 ASME/ANSI CLASS 1500 (PN 250)

DIMENSIONS

SIZE in.	Ball Bore B	Stem Size	RF Length A	RTJ Length A	Dia. D1	Dia. D2	Weld End + Length A	C.L. to Bottom C	Body Sphere E	Lever Length L	Diameter Handwheel for Gear G	C.L. to Handwheel C.L. H	Flange	Valve lb. Weld
2	2.06	1.0	14.50	14.625	8.50	2.06	11.0*	3.94	5.00	24	-	6.34	100	45
3	3.13	1.5	18.50	18.625	10.50	3.13	13.5*	4.88	7.00	36	-	7.44	180	120
4	4.06	2.0	21.50	21.625	12.25	4.06	15.0*	6.77	9.25	-	18	9.76	300	190
6	6.00	2.0	27.75	28.000	15.50	6.00	20.0*	8.39	12.50	-	30	10.86	715	410
8	8.00	3.0	32.75	33.125	19.00	8.00	23.5*	10.95	16.38	-	18	16.89	1550	1075
10	10.00	4.0	39.00	39.375	23.00	10.00	25.5*	15.15	19.50	-	18	19.96	2000	1575
12	12.00	4.0	44.50	45.125	26.50	12.00	29.5*	17.31	23.38	-	24	21.80	3250	1825
14	12.75	5.0	49.50	50.250	29.50	12.75	31.5*	17.40	26.00	-	24	25.30	4200	2550
16	14.75	5.0	54.50	55.375	32.50	14.75	33.5*	19.02	29.25	-	30	26.92	5400	2950
18	16.75	7.5	60.50	61.375	36.00	16.75	36.5*	22.69	31.57	-	30	33.71	6350	5125
20	18.625	7.5	65.50	66.375	38.75	18.625	38.5*	24.22	34.72	-	30	35.23	9260	6025
24	22.50	7.5	76.50	77.625	46.00	22.50	45.0*	28.07	42.16	-	48	38.18	16250	9400
SIZE mm														kg
50	52	25	368	371	216	52	279*	100	127	610	-	161	45	20
80	80	38	470	473	267	80	343*	124	178	914	-	189	82	54
100	103	51	546	549	311	103	381*	172	235	-	457	248	136	86
150	152	51	705	711	394	152	508*	213	318	-	762	276	324	186
200	203	76	832	841	483	203	597*	278	416	-	457	429	703	488
250	254	102	991	1000	584	254	648*	385	495	-	457	507	907	714
300	305	102	1130	1146	673	305	749*	440	394	-	610	554	1474	828
350	324	127	1257	1276	749	324	800*	442	660	-	610	643	1905	1157
400	375	127	1384	1407	826	375	851*	483	743	-	762	684	2449	1338
450	425	191	1537	1559	914	425	927*	576	802	-	762	856	2880	2325
500	473	191	1664	1686	984	473	978*	615	882	-	762	895	4200	2733
600	572	191	1943	1972	1168	572	1143*	713	1071	-	1219	970	7371	4264

+ Length (A) of a weld x flanged end valve is one half the sum of length (A) of a weld end and a flange end of the same size and rating.

* Short pattern.

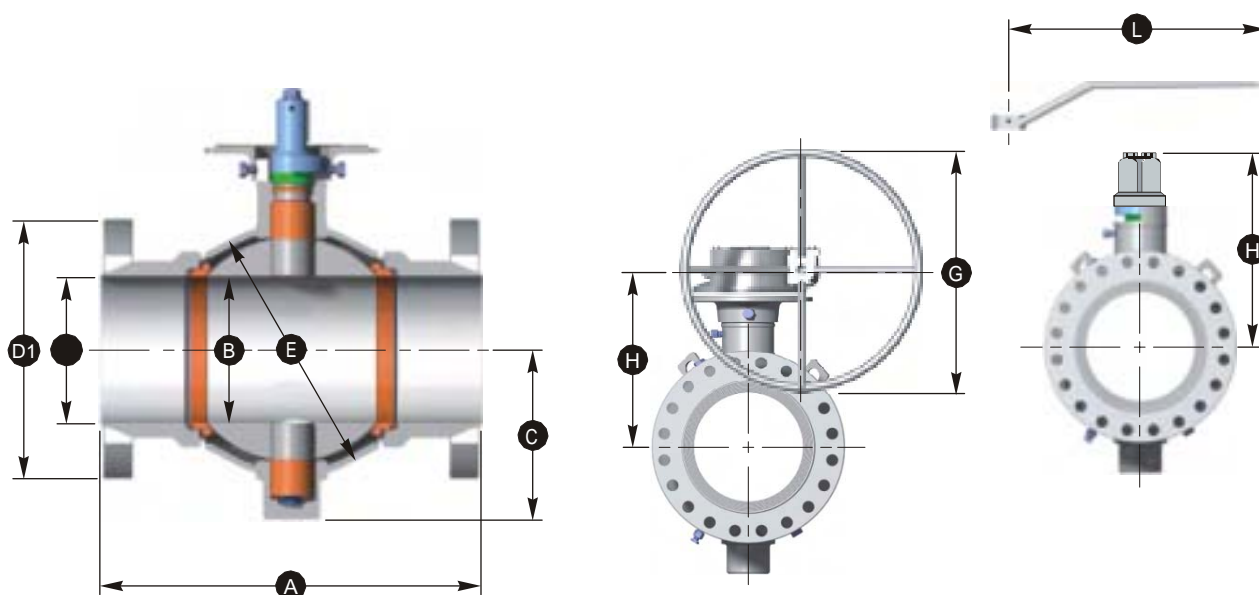
缩径 ASME/ANSI CLASS 1500 (PN 250)



DIMENSIONS

SIZE in.	Ball Bore B	Stem Size	RF Length A	RTJ Length A	Dia. D1	Dia. D2	Weld End + Length A	C.L. to Bottom C	Body Sphere E	Lever Length L	Diameter Handwheel for Gear G	C.L. to Handwheel C.L. H	Flange	Valve lb. Weld
3	2.06	1.0	18.50	18.625	10.50	3.13	11.0*	3.94	5.00	24	-	6.34	150	70
4	3.13	1.5	21.50	21.625	12.25	4.06	13.5*	4.88	7.00	36	-	7.44	240	150
6	4.06	2.0	27.75	28.000	15.50	6.00	15.0*	6.77	9.25	-	18	9.76	550	260
8	6.00	2.0	32.75	33.125	19.00	8.00	20.0*	8.39	12.50	-	30	10.86	1025	650
10	8.00	3.0	39.00	39.375	23.00	10.00	23.5*	10.95	16.38	-	18	16.89	1725	1200
12	10.00	4.0	44.50	45.125	26.50	12.00	25.5*	15.15	19.50	-	18	19.96	2810	1650
14	12.00	4.0	49.50	50.250	29.50	12.75	29.5*	17.31	23.38	-	24	21.80	3750	2100
16	12.75	5.0	54.50	55.375	32.50	14.75	31.5*	17.40	26.00	-	24	25.30	5150	2725
SIZE mm													kg	
80	52	25	470	473	267	80	279*	100	127	610	-	161	68	32
100	90	38	546	549	311	103	343*	124	178	914	-	189	109	68
150	103	51	705	711	394	152	381*	172	235	-	457	248	249	118
200	152	51	832	841	483	203	508*	213	318	-	762	276	465	295
250	203	76	991	1000	584	254	597*	278	416	-	457	429	782	544
300	254	102	1130	1146	673	305	648*	385	495	-	457	507	1275	748
350	305	102	1257	1276	749	324	749*	440	594	-	610	554	1701	953
400	324	127	1384	1407	826	375	800*	442	660	-	610	643	2336	1236

+ Length (A) of a weld x flanged end valve is one half the sum of length (A) of a weld end and a flange end of the same size and rating.

* Short pattern.

Note: Venturi opening or other reduced bore valves are available upon request.

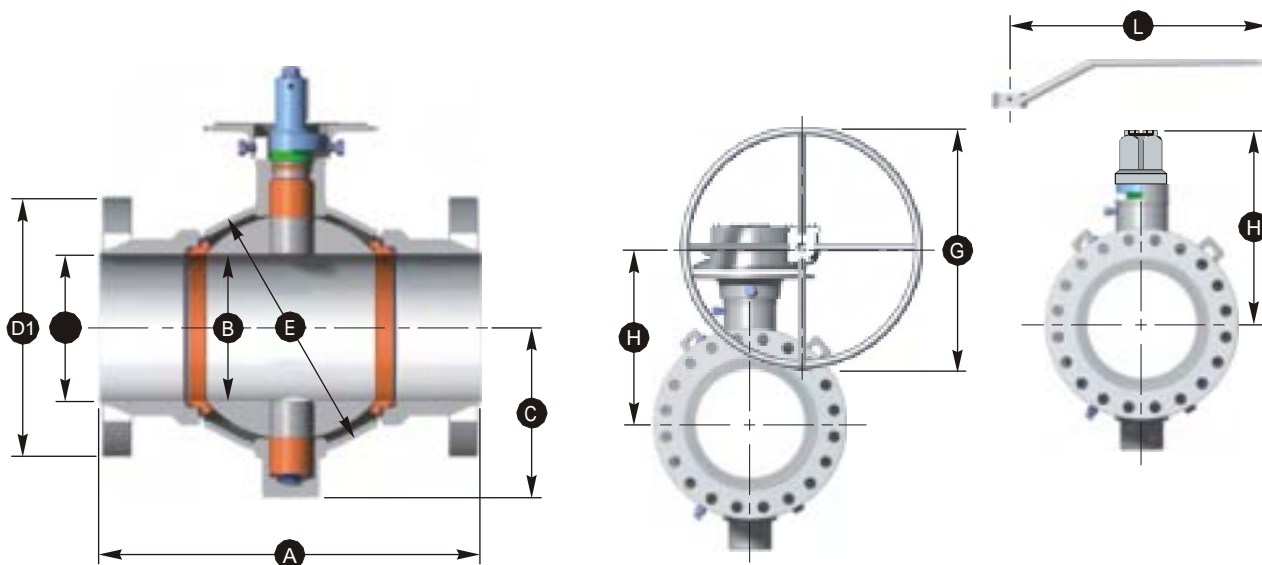
全通径和缩径 ASME/ANSI CLASS 2500 (PN 420)

DIMENSIONS

SIZE in.														
Nom Dia.	Ball Bore B	Stem Size	RF Length A	RTJ Length A	Dia. D1	Dia. D2	Weld End + Length A	C.L. to Bottom C	Body Sphere E	Lever Length L	Diameter Handwheel for Gear G	C.L. to Handwheel C.L. Flange H	Valve lb.	Weld
FULL OPENING														
2	2.06	1.0	17.75	17.875	9.25	2.06	15*	4.53	5.43	24	-	7.25	114	94
3	3.13	1.5	22.75	23.000	12.00	3.13	18*	5.67	7.50	36	-	8.94	236	187
4	4.06	2.0	26.50	26.875	14.00	4.06	20*	7.24	9.75	-	24	11.70	471	382
6	6.00	3.0	36.00	36.500	19.00	6.00	24*	9.76	13.50	-	24	13.13	943	737
8	7.125	4.0	40.50	40.875	21.75	7.125	28*	12.84	18.11	-	24	17.88	2094	1676
10	8.875	4.0	50.00	50.875	26.50	8.875	33*	14.84	20.87	-	24	20.00	2922	2166
12	10.50	5.0	56.00	56.875	30.00	10.50	36*	16.65	24.50	-	30	24.75	4506	3258
REDUCED OPENING														
3	2.06	1.0	22.75	23.000	12.00	3.13	15*	4.53	5.43	21	-	7.25	156	129
4	3.13	1.5	26.50	26.875	14.00	4.06	18*	5.67	7.50	36	-	8.94	286	247
6	4.06	2.0	36.00	36.500	19.00	6.00	20*	7.24	9.75	-	24	11.70	638	513
8	6.00	3.0	40.50	40.875	21.75	7.125	24*	9.76	13.50	-	24	13.13	1297	1017
10	7.13	4.0	50.00	50.875	26.50	8.875	28*	12.84	18.11	-	24	17.88	2518	1916
12	8.875	4.0	56.00	56.875	30.00	10.50	33*	14.875	20.87	-	24	20.00	3566	2657
SIZE mm														
FULL OPENING														
50	52	25	451	454	235	52	381*	115	138	610	-	184	52	43
80	80	38	578	584	305	80	457*	144	191	914	-	227	107	85
100	103	51	673	683	356	103	508*	184	248	-	610	297	214	173
150	152	76	914	927	483	152	610*	248	343	-	610	334	428	334
200	181	102	1029	1038	552.5	181	711*	326	460	-	610	454	950	760
250	225	102	1270	1292	673	225	838*	378	530	-	610	508	1325	983
300	267	127	1422	1445	762	267	914*	423	622	-	762	629	2044	1478
REDUCED OPENING														
80	42	25	578	584	305	80	381*	115	138	610	-	184	71	59
100	80	38	673	683	356	103	457*	144	191	914	-	227	130	98
150	103	51	914	927	483	152	508*	184	248	-	610	297	289	233
200	152	76	1029	1038	553	181	610*	248	343	-	610	334	588	461
250	181	102	1270	1292	673	225	711*	326	460	-	610	454	1142	869
300	225	102	1422	1445	762	267	838*	377	530	-	610	508	1618	1205

+ Length (A) of a weld x flanged end valve is one half the sum of length (A) of a weld end and a flange end of the same size and rating.

* Short pattern.

Note: Venturi opening or other reduced bore valves are available upon request.

全通径 API FLANGED 2000, 3000 & 5000 psi WP

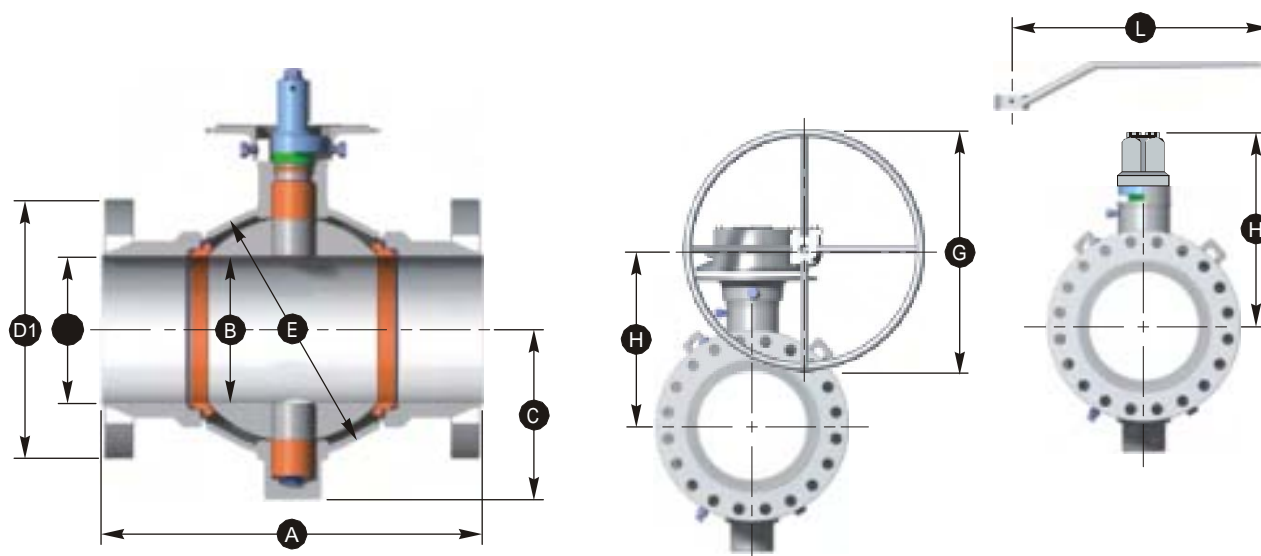

DIMENSIONS

SIZE in.	Flanged-End RTJ C.L. to Bottom						Body Sphere E	Lever Length L	Diameter Handwheel for Gear G	Data for Valve with Operator Normally Furnished Approx. Weight lb.	
Nom Dia.	Ball Bore B	Stem Size	Length A	Length D1	Dia. D2	Bottom C				H	
2000 psi W.P. 4000 psi TEST											
2	2.06	1.0	11.625	6.50	2.06	3.94	5.00	36	-	6.34	44
3	3.13	1.0	14.124	8.25	3.13	5.12	6.75	36	-	7.44	85
4	4.06	1.5	17.125	10.75	4.06	5.94	8.50	36	-	8.43	165
7	6.00	2.0	22.125	14.00	6.00	7.91	11.50	-	24	10.29	445
3000 psi W.P. 6000 psi TEST											
2	2.06	1.0	14.625	8.50	2.06	3.94	5.00	36	-	6.34	90
3	3.13	1.5	15.125	9.50	3.13	4.88	7.00	36	-	7.44	130
4	4.06	2.0	18.125	11.50	4.06	6.77	9.25	36	-	9.76	255
7	6.00	2.0	24.125	15.00	6.00	8.39	12.50	-	30	10.92	675
5000 psi W.P. 10000 psi TEST											
2	2.06	2.0	14.625	8.50	2.06	3.94	5.00	36	-	6.34	95
3	3.13	1.5	18.625	10.50	3.13	4.88	7.00	36	-	7.44	189
4	4.06	2.0	21.625	12.25	4.06	6.77	9.25	-	24	9.30	361
7	6.00	3.0	28.000	15.50	6.00	8.39	13.50	-	24	13.13	805
SIZE mm											
140.6 kg/cm² W.P. 281.2 kg/cm² TEST											
50	52.3	25.4	295	165	52	100	127	914	-	161	20
80	79.5	25.4	359	210	80	130	171	914	-	189	39
100	103.1	38.1	435	274	103	151	216	914	-	214	75
180	152.4	50.8	562	356	152	201	292	-	610	261	202
210.9 kg/cm² W.P. 421.8 kg/cm² TEST											
50	52.3	25.4	371	216	52	100	127	914	-	161	41
80	79.5	38.1	384	241	80	124	178	914	-	189	59
100	103.1	50.8	460	292	103	172	235	914	-	248	116
180	152.4	50.8	613	381	152	213	318	-	762	277	306
351.5 kg/cm² W.P. 703.0 kg/cm² TEST											
50	52.3	25.4	371	216	52	100	127	914	-	161	43
80	79.5	38.1	473	267	80	124	178	914	-	189	86
100	103.1	50.8	549	311	103	172	235	914	-	236	164
180	152.4	76.2	711	394	152	213	343	-	610	334	365

缩径 API FLANGED 2000, 3000 & 5000 psi W.P.

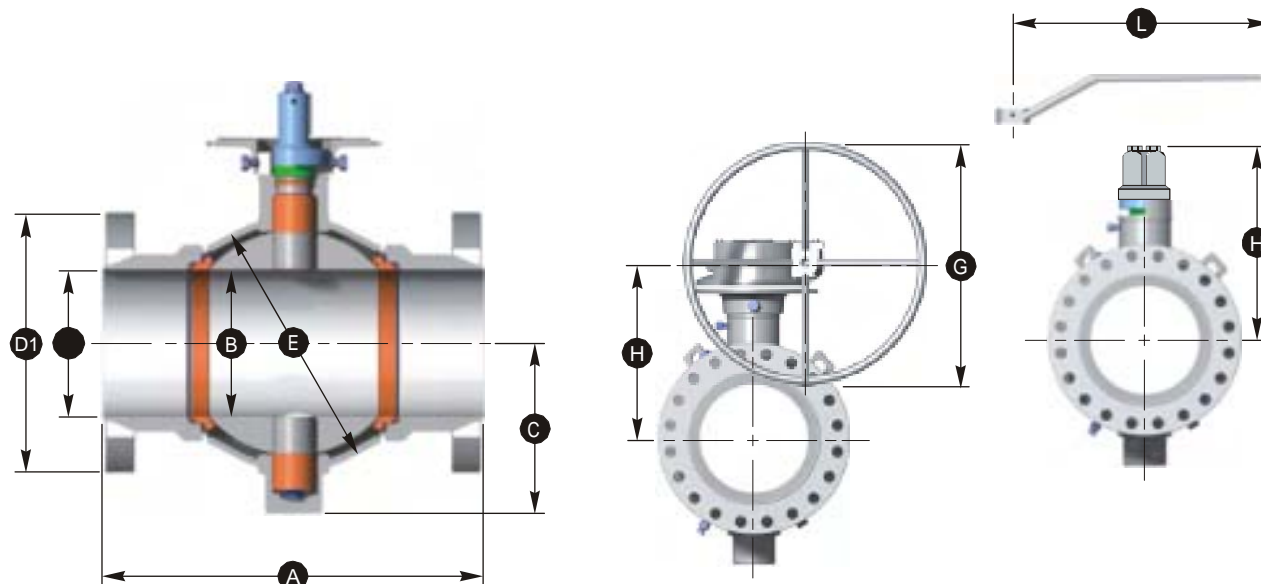
DIMENSIONS

SIZE in.	Nom Dia.	Ball Bore B	Stem Size	Flanged End RTJ			C.L. to Bottom C	Body Sphere E	Lever Length L	Diameter Handwheel for Gear G	Data for Valve with Operator Normally Furnished	
				Length A	Dia. D1	Dia. D2					H	Approx. Weight lb. Flange
2000 psi W.P. 4000 psi TEST												
	3.13	2.06	1.0	14.125	8.25	3.13	3.94	5.00	36	-	6.34	80
	4.06	3.13	1.0	17.125	10.75	4.06	5.12	6.75	36	-	7.44	140
	7.06	4.06	1.5	22.125	14.00	6.00	5.94	8.50	36	-	8.43	230
3000 psi W.P. 6000 psi TEST												
	3.13	2.06	1.0	15.125	9.50	3.13	3.94	5.00	36	-	6.34	105
	4.06	3.13	1.5	18.125	11.50	4.06	4.88	7.00	36	-	7.44	197
	7.06	4.06	2.0	24.125	15.00	6.00	6.77	9.25	36	-	9.76	345
5000 psi W.P. 10000 psi TEST												
	3.13	2.06	1.0	18.625	10.50	3.13	3.94	5.00	36	-	6.34	130
	4.06	3.13	1.5	21.625	12.25	4.06	4.88	7.00	36	-	7.44	230
	7.06	4.06	2.0	28.000	15.50	6.00	6.77	9.25	-	24	9.30	490
SIZE mm												kg Flange
140.6 kg/cm ² W.P. 281.2 kg/cm TEST												
	79.5	52.3	25.4	359	210	80	100	127	914	-	161	36
	103.1	79.5	25.4	435	273	103	130	171	914	-	189	64
	179.3	103.1	38.1	562	356	152	151	216	914	-	214	104
210.9 kg/cm ² W.P. 421.8 kg/cm TEST												
	79.5	52.3	25.4	384	241	80	100	127	914	-	161	48
	103.1	79.5	38.1	460	292	103	124	178	914	-	189	89
	179.4	103.1	50.8	613	381	152	172	235	914	-	248	156
351.5 kg/cm ² W.P. 703.0 kg/cm TEST												
	79.5	52.3	25.4	473	267	80	100	127	914	-	161	59
	103.1	79.5	38.1	549	311	103	124	178	914	-	189	104
	179.3	103.1	50.8	711	394	152	172	235	-	610	236	222

尺寸信息

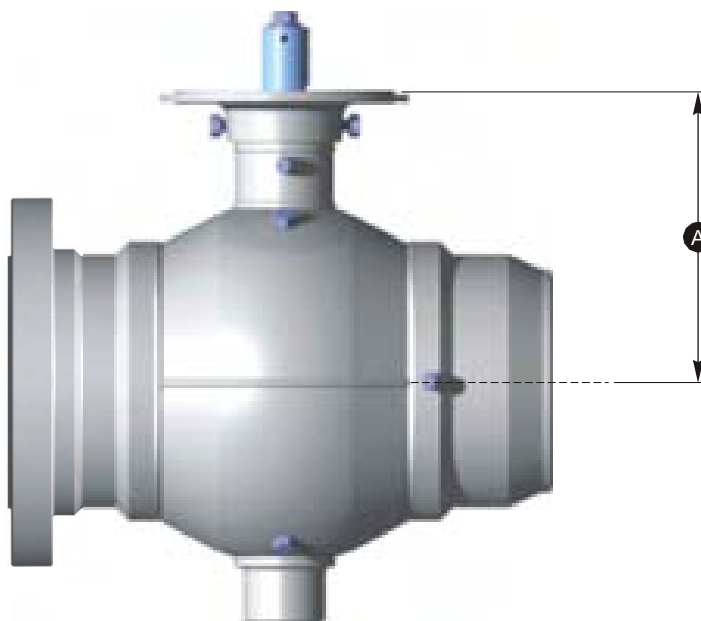

中心线至适配法兰尺寸

Bore Size in. (mm)	Dimension A ASME/ANSI Pressure Class						
	150 (PN 20)	300 (PN 50)	400 (PN 64)	600 (PN 100)	900 (PN 150)	1500 (PN 250)	2500 (PN 420)
2 (50)	4.06 (103)	4.06 (103)	4.06 (103)	4.06 (103)	4.06 (103)	4.06 (103)	4.68 (119)
3 (80)	5.08 (129)	5.08 (129)	5.08 (129)	5.08 (129)	4.76 (121)	4.76 (121)	5.71 (145)
4 (100)	5.79 (147)	5.79 (147)	5.79 (147)	5.79 (147)	6.61 (168)	6.61 (168)	6.89 (175)
6 (150)	7.64 (194)	7.64 (194)	7.64 (194)	7.64 (194)	8.23 (209)	8.23 (209)	12.52 (318)
8 (200)	9.92 (252)	9.92 (252)	9.92 (252)	9.92 (252)	9.92 (252)	13.45 (342)	15.39 (391)
10 (250)	11.91 (303)	11.91 (303)	11.91 (303)	11.91 (303)	15.05 (382)	15.96 (405)	18.07 (459)
12 (300)	16.70 (424)	16.70 (424)	16.70 (424)	16.70 (424)	16.70 (424)	17.80 (452)	19.61 (498)
14 (350)	17.72 (450)	17.72 (450)	17.72 (450)	17.72 (450)	20.55 (522)	20.55 (522)	-
16 (400)	19.08 (485)	19.08 (485)	20.78 (528)	20.78 (528)	22.17 (563)	22.17 (563)	-
18 (450)	22.19 (564)	22.19 (564)	22.19 (564)	22.19 (564)	23.76 (604)	27.71 (704)	-
20 (500)	23.75 (603)	23.75 (603)	25.25 (641)	25.25 (641)	29.23 (742)	29.23 (742)	-
22 (550)	25.22 (641)	25.22 (641)	26.78 (680)	26.78 (680)	-	-	-
24 (600)	26.63 (676)	26.63 (676)	28.20 (716)	28.20 (716)	32.18 (817)	32.18 (817)	-
26 (650)	29.59 (752)	29.59 (752)	29.59 (752)	29.59 (752)	-	-	-
28 (700)	30.97 (787)	30.97 (787)	30.97 (787)	34.99 (889)	-	-	-
30 (750)	32.62 (829)	32.62 (829)	32.62 (829)	36.65 (931)	36.65 (931)	-	-
34 (850)	35.26 (896)	35.26 (896)	39.31 (998)	39.31 (998)	-	-	-
36 (900)	36.85 (936)	40.92 (1039)	40.92 (1039)	40.92 (1039)	44.65 (1134)	-	-
40 (1000)	44.25 (1124)	44.25 (1124)	44.25 (1124)	48.05 (1220)	-	-	-
42 (1050)	45.89 (1166)	45.89 (1166)	45.89 (1166)	49.69 (1262)	-	-	-
48 (1200)	50.04 (1271)	50.04 (1271)	54.02 (1372)	56.50 (1435)	-	-	-

The dimensions on this page, combined with the top works dimensions on the following two pages, provide the information required for determining the overall dimensions of a Cameron Fully Welded Ball Valve when an actuator is installed.

For additional dimensional information on Cameron Fully Welded Ball Valves, contact your Cooper Cameron Valves representative.

卡麦隆球阀顶装尺寸

卡麦隆球阀方形阀杆驱动套和适配法兰 (BX-1220)

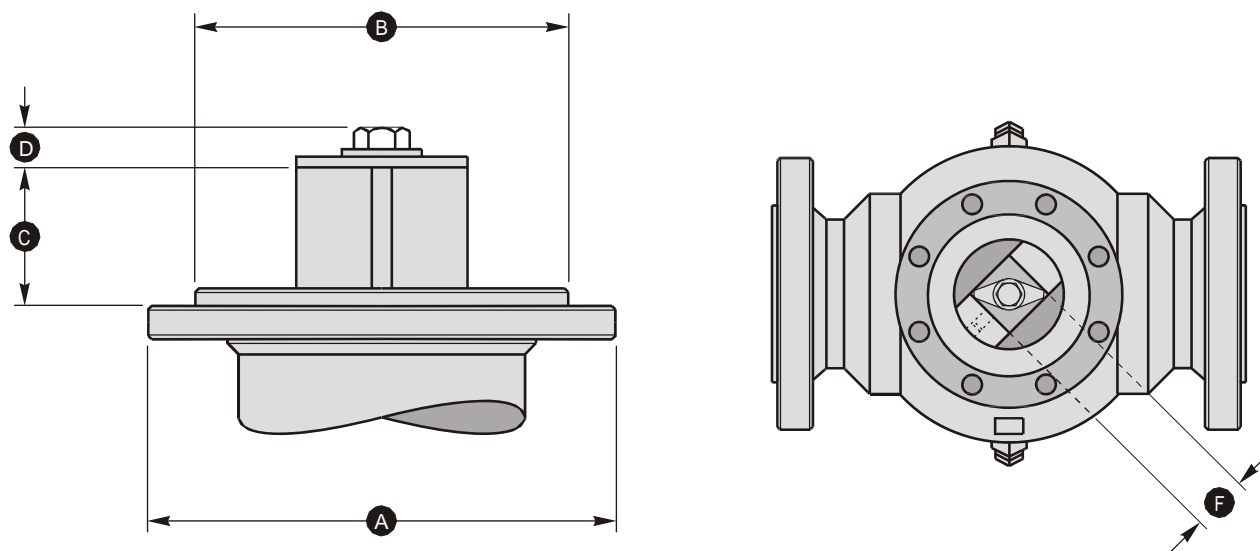

与执行机构配套尺寸

DASH NUMBER	-1	-2	-3
Valve Stem Size in.	1.00	1.50	2.00
A Flange Dia.	6.50	6.50	8.75
B Boss Dia.	4.747	4.747	6.997
C Height of Nut	1.94	2.12	2.62
D Bolt Size	0.44	0.54	0.66
F Width of Nut	1.50	2.00	2.50
H Number of Holes	8	8	16
J Dia. Bolt Circle	5.75	5.75	8.00
Flange Bolt Size	3/8-16 NC-2	3/8-16 NC-2	3/8-16 NC-2
Bolt Torque (ft. lb.)	30	30	30
DASH NUMBER	-1	-2	-3
Valve Stem Size mm	25.40	38.10	50.80
A Flange Dia.	165.10	165.10	222.25
B Boss Dia.	120.57	120.57	177.72
C Height of Nut	49.28	53.85	66.55
D Bolt Size	11.18	13.72	16.76
F Width of Nut	38.10	50.8	63.50
H Number of Holes	8	8	16
J Dia. Bolt Circle	146.05	146.05	203.20
Flange Bolt Size	3/8-16 NC-2	3/8-16 NC-2	3/8-16 NC-2
Bolt Torque (Nm)	40.68	40.68	40.68

Notes: -1 and -2 bolt holes straddle centerline.
 -3 bolt holes are on centerline.

卡麦隆顶装尺寸

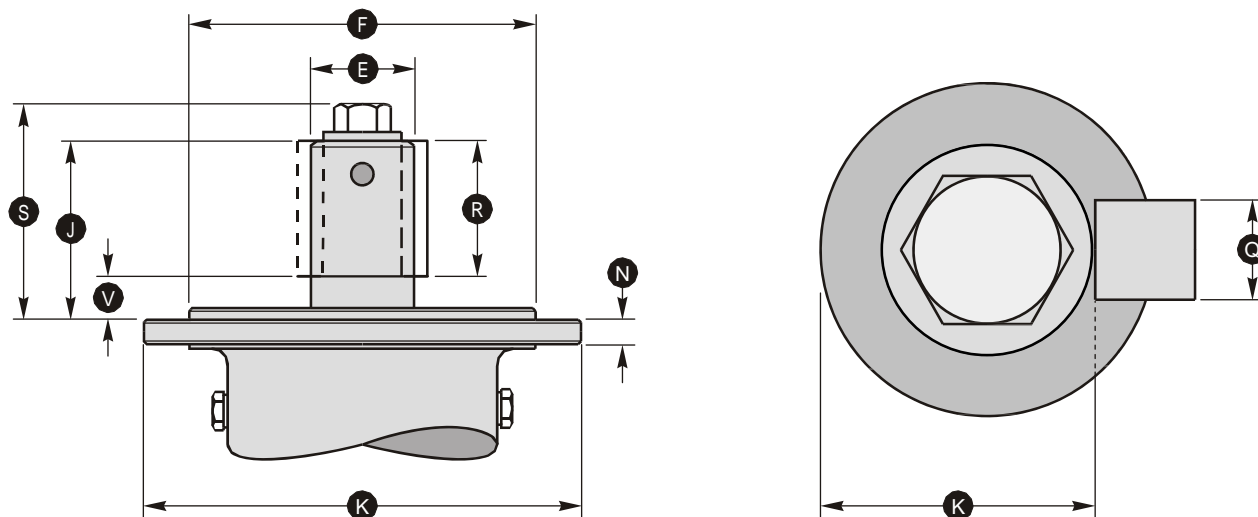
卡麦隆球阀键式阀杆和适配法兰 (BX-1221)



与执行机构配套尺寸

阀杆尺寸 in.		3.00	4.00	5.00	7.50	9.00	11.00	13.00	15.00
C Dia. Bolt Circle		10.375	17.25	18.375	24.00	31.00	27.50	27.50	36.00
F Boss Dia.		9.122	16.246	17.121	21.746	28.308	25.496	25.496	33.496
J Height of Nut		4.75	5.310	6.25	8.50	9.13	13.31	13.31	19.25
N Flange Thickness		0.63	0.63	0.63	1.00	1.00	1.25	1.25	1.50
R Height of Boss		3.75	4.310	5.250	7.50	8.13	12.00	12.00	17.50
V Adapter Flange Thickness		1.00	1.00	1.00	1.00	1.00	1.25	1.25	1.50
Bolt Torque (ft. lb.)		60	60	63	330	330	1000	1000	1600
Valve Stem Size mm		76.20	101.60	127.00	190.50	228.60	279.40	330.20	381.00
C Dia. Bolt Circle		263.53	438.15	466.73	609.60	787.40	698.50	698.50	914.40
F Boss Dia.		231.69	412.64	434.87	552.34	719.02	647.59	647.59	850.79
J Height of Nut		120.65	134.88	158.75	215.90	231.91	338.03	338.03	488.95
N Flange Thickness		16.00	16.00	16.00	25.40	25.40	31.75	31.75	38.10
R Height of Boss		95.25	109.48	133.35	190.50	206.51	304.80	304.80	444.50
V Adapter Flange Thickness		25.40	25.40	25.40	25.40	25.40	31.75	31.75	38.10
Bolt Torque (Nm)		81	81	85	447	447	1356	1356	2169

Notes: -7 through -11 bolt holes straddle centerline.
-4 through -6 holes are on centerline.

卡麦隆球阀顶装尺寸图

卡麦隆球阀的手动齿轮操作机构尺寸 - ROTORK

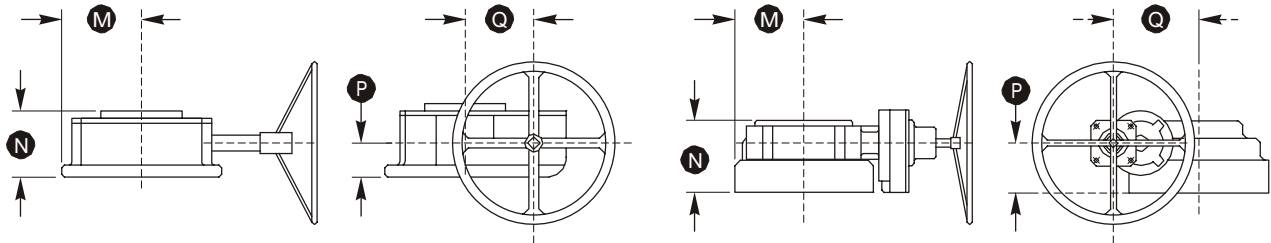

Rotork 齿轮箱
阀杆尺寸: 1 in., 1.5 in. & 2 in. (25 mm, 40 mm & 50 mm)

Rotork 齿轮箱
阀杆尺寸: 3 in. (80 mm)

Stem Size Weight in. (kg)	(mm)	Effective Model	Number of Ratio	Turns Per 90°	M	N	P	Q	lb.
1.0 (25.4)	AB 880N	13:2	9.5	3.94 (100)	3.58 (91)	1.92 (49)	3.39 (86)	31	(14)
1.5 (38.1)	AB 880N	13:2	9.5	3.94 (100)	3.58 (91)	1.92 (49)	3.39 (86)	31	(14)
2.0 (50.8)	AB 1950N	19:0	13	5.61 (143)	4.68 (119)	2.51 (64)	5.37 (137)	71	(32)

卡麦隆球阀的手动齿轮操作机构尺寸- MASTERGEAR

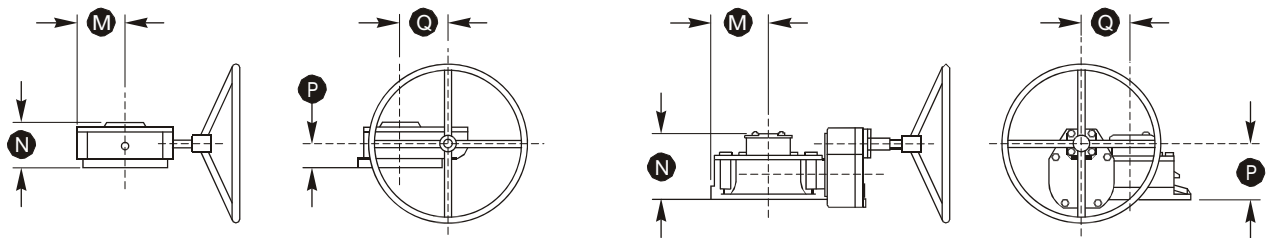

Mastergear 齿轮箱
阀杆尺寸: 1 in., 1.5 in. & 2 in. (25 mm, 40 mm & 50 mm)

Mastergear 齿轮箱
阀杆尺寸: 3 in. (80 mm)

Stem Size Weight in. (kg)	(mm)	Effective Model	Number of Ratio	Turns Per 90°	M	N	P	Q	lb.
1.0 (25.4)	MA46	11:1	11.5	3.63 (92)	4.66 (118)	2.50 (64)	3.38 (86)	33	(15)
1.5 (38.1)	MA46	11:1	11.5	3.63 (92)	4.66 (118)	2.50 (64)	3.38 (86)	33	(15)
2.0 (50.8)	MC72	18.3:1	18	4.75 (121)	5.14 (131)	2.63 (67)	5.38 (137)	68	(31)
3.0 (76.2)	MFF36/S5	52:1	45	6.10 (155)	6.76 (172)	5.91 (150)	5.43 (138)	135	(61)

卡麦隆球阀顶装尺寸图

卡麦隆球阀的手动齿轮操作机构尺寸- CAMERON

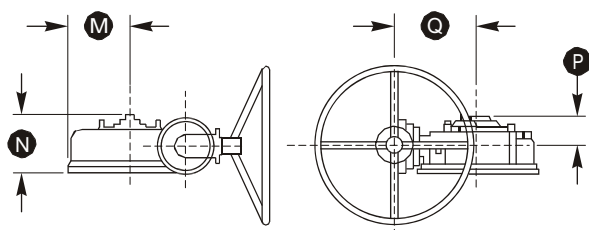

SD-24024

Model WG1/B6

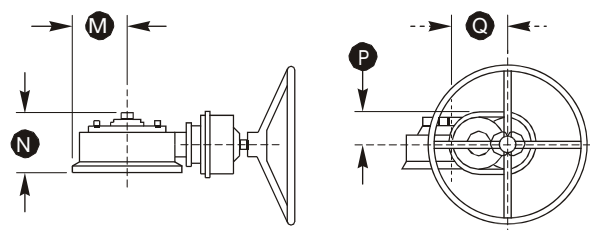

SD-24025

Model WG1/S12

Cameron 齿轮箱
阀杆尺寸: 3 in. & 4 in.(80 mm & 100 mm)

Cameron 齿轮箱
阀杆尺寸: 5 in., 7.5 in. & 9 in. (125 mm, 190 mm & 230 mm)

Weight in.	(mm)	Stem Size Model	Effective Ratio	Number of Turns Per 90°	M	N	P	Q	
							lb.	(kg)	
3.0	(76.2)	WG1/B6	55:1	60	5.75 (146)	7.56 (192)	4.11 (104)	12.64 (321)	127 (58)
4.0	(101.6)	WG1/B6	110:1	112.5	9.13 (232)	8.69 (221)	4.69 (119)	12.64 (321)	211 (96)
5.0	(127.0)	WG1/S12	153:1	190	9.69 (246)	10.25 (260)	5.50 (140)	9.50 (241)	364 (165)
7.5	(190.5)	WG1/S12	297:1	297	12.88 (327)	12.63 (321)	6.63 (168)	14.00 (356)	581 (264)

TERMS AND CONDITIONS

1. CONTRACT ACCEPTANCE:

Any written or oral purchase order received from Buyer by Cooper Cameron Corporation, Cameron Division and Cooper Cameron Valves ("Seller") shall be construed as a written acceptance of Seller's offer to sell and shall be filled in accordance with the terms and conditions of sale set forth herein. SELLER'S ACCEPTANCE OF THIS ORDER IS EXPRESSLY CONDITIONED ON BUYER'S ASSENT TO THE TERMS CONTAINED HEREIN. The terms and conditions of Seller's proposal (if any) and acknowledgement shall prevail over any conflicting or different terms in Buyer's order unless Buyer notifies Seller in writing of its objections thereto within fifteen (15) days from receipt of Seller's acknowledgement. Buyer's standard terms of purchase will not be considered a counteroffer to Seller's terms and conditions of sale. The failure of Seller to object to any provision in conflict herewith whether contained on Buyer's purchase order or otherwise shall not be construed as a waiver of the provisions hereof nor as an acceptance thereof.

2. QUOTATIONS AND PRICES:

All quotations are made for prompt acceptance and any terms quoted therein are subject to change without notice after thirty (30) days from the date quoted unless specifically stated otherwise on the quotation. Any product, service capability or manufacturing capability which may be available at the time a quotation is made is subject to prior sale. Prices quoted are valid for thirty (30) days unless specifically stated otherwise on the quotation and are subject to change without notice. The price in effect at the time of shipment including any escalation formula will apply, unless a valid quotation or written agreement to the contrary exists between Buyer and Seller. All prices shown are in U.S. dollars and are F.O.B. Seller's shipping point. Any documentation pertaining to traceability requirements for raw materials or products or documentation required for any routine or special processes must be identified by the Buyer at the time of quotation (if any) or at the time of order placement.

3. TAXES:

Any tax or other charge imposed by law on the sale or production of goods or the performance of services shall be paid by the Buyer, unless the law specifically provides that such payment must be made by Seller, in which case Buyer shall reimburse Seller for such payment as part of the purchase price. Custom duties, consular fees, insurance charges and other comparable charges will be borne by Buyer.

4. SHIPPING SCHEDULE AND DELIVERY:

Shipment schedules are given as accurately as conditions permit and every effort will be made to make shipments as scheduled. Seller will not be responsible for deviations in meeting shipping schedules nor for any losses or damages to Buyer (or any third party) occasioned by deviations in the shipping schedule, whether due to Acts of God, orders bearing priority ratings established pursuant to law, differences with workmen, local labor shortages, fire, flood, shortages or failure

of raw materials, supplies, fuel, power or transportation, breakdown of equipment or any other causes beyond Seller's reasonable control, whether of similar or dissimilar nature than those enumerated. Seller shall have additional time within which to perform as may be reasonably necessary under the circumstances and shall have the right to apportion its production among its customers in such a manner as it may consider to be equitable.

Seller reserves the right to furnish commercially equivalent or better substitutes for materials or to subcontract the Buyer's order or portions thereof as Seller deems necessary. In no event shall Seller be liable for any consequential damages for labor resulting from failure or delay in shipment. If Buyer requires drawings, procedures, standards or similar material for approval, shipping schedules will be calculated from the time such approvals are received by Seller, since shipping schedules are based on Seller having all required information and a firm order from Buyer which is enterable into production. Any hold points, witness points or the need for inspection by Buyer's representatives must be identified by Buyer at the time of quotation (if any) and/or order placement in order that the effect on the prices or shipping schedules (if any) can be taken into account. Additional inspection or testing required by Buyer which affects normal production sequence will be considered as extending the shipping dates accordingly.

5. MINIMUM BILLING:

Seller reserves the right to impose a minimum billing charge on all sales, change orders or order supplements.

6. TERMS OF PAYMENT:

Terms of payment for all materials and service are 30 days from invoice date, at net price, provided satisfactory credit has been established. All unpaid invoices are subject to the maximum legal interest rate per annum commencing with the due date.

7. CANCELLATIONS AND RETURNS:

Purchase orders once placed by Buyer and accepted by Seller can be canceled only with Seller's written consent and upon terms which will save Seller from loss. No products may be returned for credit or adjustment without written permission from Seller's office authorized to issue such permission.

8. WARRANTIES:

All products of Seller's manufacture are warranted against defects of material and workmanship for a period of twelve (12) months from the date of installation or eighteen (18) months from date of shipment, whichever period first expires, when such products are used in the service and within the pressure range for which they were manufactured. In the case of products or parts not wholly of Seller's manufacture, Seller's liability shall be limited to the extent of its recovery from the manufacturer of such products or parts under its liability to Seller.

Any repair work performed by Seller is warranted for one year from completion of such repairs and applies only to work performed.

If, within these specified periods, Seller notice from Buyer of any alleged defect in or nonconformance of any product or repair and if, in the Seller's sole judgment, the product or repair does not conform or is found to be defective in material or workmanship, then, Buyer shall, at Seller's request, return the part or product F.O.B. to Seller's designated plant or service location. Seller has no liability for removal or reinstallation of products or equipment from below the surface of the water. Seller, at its option and expense, shall repair or replace the defective part or product, or repay to Buyer the full price paid by Buyer for such defective part, repair or product. Any repayment of purchase price shall be without interest.

Seller's warranty liability, including defects caused by Seller's negligence, shall be limited to such repair, replacement or refund, and shall not include claims for labor costs, expenses of Buyer resulting from such defects, recovery under general tort law or strict liability or for damages resulting from delays, loss of use, or other direct, indirect, incidental or consequential damages of any kind. Seller will not be responsible for failures of products which have been in any way tampered with or altered by anyone other than an authorized representative of Seller, failures due to lack of compliance with recommended maintenance procedures or products which have been repaired or altered in such a way (in Seller's judgment) as to affect the products adversely. THIS WARRANTY IS EXPRESSLY IN LIEU OF ALL OTHER WARRANTIES, EXPRESS, STATUTORY OR IMPLIED, INCLUDING THE WARRANTY OF MERCHANTABILITY AND FITNESS FOR PARTICULAR PURPOSE WHICH EXCEED THE FOREGOING WARRANTY.

9. NUCLEAR SALES:

The products sold hereunder are not designed or manufactured for use in or with any atomic installation or activity. If the Buyer or ultimate user of these products intends to use them in such an installation or activity, Seller's Nuclear Terms of Sale shall be part of and control this contract. Seller will furnish Buyer with a copy of its Nuclear Terms of Sale upon request.

10. PATENT INFRINGEMENT:

Seller warrants that the use or sale of material or apparatus sold or rented by it to Buyer hereunder will not infringe United States' patents of others covering such material or apparatus by itself, and hereby agrees to indemnify Buyer against judgment for damages for such infringement of any such patent, provided that Buyer shall, upon receipt of any claim for infringement of any such patent or threat of suit for such infringement or upon the filing of any suit for infringement, whichever comes first, promptly notify Seller in writing and afford Seller full opportunity, at its option and its own expense, to answer such claim or threat of suit, assume the control of the defense of said suit, and settle or compromise same in any way Seller sees fit. Other than court-awarded judgments as aforesaid Seller shall not be liable

for any delays, loss of use or for other direct, indirect, incidental or consequential damages incurred by reason of any such judgment. Seller does not warrant that such material or apparatus (a) will not infringe any such patent when not manufactured by or for Seller or when specially made in whole or in part to the Buyer's design specification and such infringement arises from the inclusion of such specified design or (b), if used or sold in combination with other material or apparatus, or if used in the practice of a process, will not, as a result of such combination or use, infringe any patent covering such combination or process; and Seller shall not be liable for and does not indemnify Buyer for damages or losses of any nature whatsoever resulting from actual or alleged patent infringement arising pursuant to (a) or (b) above.

11. SELLER'S RIGHT TO MANUFACTURE: Seller in its sole discretion shall have the right to manufacture the products provided hereunder as far in advance of its estimated shipping schedule as it deems appropriate. Seller expressly reserves the right to change or modify the design and construction of any product in due course of Seller's manufacturing procedure without incurring any obligation or liability to furnish or install such changes, modifications or improvements to products previously or subsequently sold.

12. ENGINEERING AND SERVICE: Upon request, Seller will provide engineering and/or technical information regarding its products and their uses and if feasible, will provide personnel to assist Buyer in effecting field installations and/or field service. Any such information, service or assistance so provided, whether with or without charge, shall be advisory only. In that regard, neither Seller nor Buyer assumes any liability for the acts or omissions of the other party except as may be provided in these terms.

13. LABOR STANDARDS: Seller hereby certifies that these products were produced in accordance with all applicable requirements of Section 6, 7 and 12 of the Fair Labor Standards Act as amended and of regulations and orders of the United States Department of Labor issued under Section 14 thereof.

14. INSPECTION: Unless otherwise agreed in writing, final inspection and acceptance of products must be made at Seller's plant or other shipping or receiving point designated by Seller and shall be conclusive except as regards latent defects. Buyer's representatives may inspect at the Seller's plant or shipping point during working hours prior to shipment in such manner as will not interfere with operations.

15. DELIVERY AND ACCEPTANCE: Delivery shall be in accordance with the requirements in the Purchase Contract, provided, in the event Buyer is unable to accept delivery upon completion of the manufacture of the Goods in accordance with such requirements,

Buyer agrees that (i) title and risk of ownership shall pass to Buyer on date of Seller's invoice and (ii) Buyer will make payments within thirty days after date of such invoice. Seller shall retain custodial risk of loss until delivery is made in accordance with such requirements.

16. TRANSPORTATION CHARGES, ALLOWANCES, CLAIMS:

All prices are F.O.B. Seller's plant or other designated shipping point.

No freight is allowed unless stated in Seller's quotation (if any) or in a written contract which may exist between Seller and Buyer at the time of shipment. If Seller's quotation or a written contract states that all or a portion of freight is allowed, all prices are F.O.B. Seller's plant or other designated shipping point, with most economical surface transportation allowed. If the quoted or contractual price includes transportation, Seller reserves the right to designate the common carrier and to ship in the manner it deems most economical. Added costs due to special routing requested by the Buyer are chargeable to the Buyer. Under no circumstances is any freight allowance which is absorbed by Seller to be deducted from the selling price. If the quoted price or contract includes transportation, no deduction will be made in lieu thereof whether Buyer accepts shipment at plant, warehouse, freight station, or otherwise supplies its own transportation. When sales are made from the Seller's warehouse, Seller reserves the right to charge either actual or pro-rated freight from Seller's principle point of manufacture to Seller's warehouse. Buyer assumes risk of loss upon delivery to the carrier, regardless of who pays shipping costs.

Seller endeavors to pack or prepare all shipments so that they will not break, rust or deteriorate in transit, but does not guarantee against such damage. Unless requested in writing by the Buyer, no shipments are insured by Seller against damage or loss in transit. Seller will place insurance as nearly as possible in accordance with Buyer's written instructions but in such case Seller acts only as agent between the insurance company and the Buyer and assumes no liability whatsoever.

Any claims for shipping loss, breakage or damage (obvious or concealed) are Buyer's responsibility and should be made to the carrier. All claims regarding shortages must be made within thirty (30) days from receipt of shipment and must be accompanied by the packing list(s) covering the shipment.

17. CONSULAR INVOICES: Consular fees for legalizing invoices, stamping bills of lading, or other documents required by the laws of any country or destination are not included in quotations or selling prices. If instructed in writing, Seller will make arrangements for consular documents and declarations as agent of the Buyer, but Seller assumes no liability whatsoever as a result of making such arrangements. Seller assumes no responsibility for any fines or other charges imposed due to errors or incorrect declarations.

18. INDEMNIFICATION AND LIMITATION OF LIABILITY:
A. INDEMNIFICATION:

Seller agrees to indemnify Buyer and hold Buyer harmless against any claims, demands or causes of action for property damage or personal injury (including death) caused by the negligent act or omission of any employee, agent or subcontractor of Seller and not contributed to by the negligence of Buyer, its employees, its agents or any third party. Seller shall not be responsible for the acts and workmanship of employees, agents, contractors or subcontractors of Buyer or any third party, nor for failure or malfunction of any tools, materials, equipment, products, supplies, facilities or devices not manufactured and supplied by Seller. Buyer agrees to hold Seller harmless from any and all losses, claims, or damages arising from subsurface damage, surface damage caused by subsurface damage, loss of hydrocarbons and from pollution, regardless of whether such damages, losses or claims were caused by the negligence or sole negligence of Seller, it being the intent of the parties that this indemnity shall apply to property of Buyer or to that of any third party.

B. LIMITATION OF LIABILITY:
UNDER NO CIRCUMSTANCES SHALL SELLER BE LIABLE FOR ANY SPECIAL, CONSEQUENTIAL OR INCIDENTAL DAMAGES, INCLUDING, BUT NOT LIMITED TO LOSS OF ANTICIPATED PROFITS, LOSS OF USE OF EQUIPMENT OR OF ANY INSTALLATION, SYSTEM OR FACILITY INTO WHICH SELLER'S EQUIPMENT MAY BE LOCATED OR AT WHICH SELLER, ITS AGENT OR SUBCONTRACTOR MAY BE PERFORMING WORK. Seller's total responsibility for any claims, damages, losses or liabilities arising out of or related to its performance of this contract or the products or services covered hereunder shall not exceed the purchase price.

19. MODIFICATION, RESCISSION & WAIVER: The terms herein may not be modified or rescinded nor any of its provisions waived unless such modification, rescission or waiver is in writing and signed by an authorized employee of Seller at its office in Houston, Texas.

Failure of Seller to insist in anyone or more instances upon the performance of any of the terms and conditions of the contract or the failure of Seller to exercise any of its rights hereunder shall not be construed as a waiver or relinquishment of any such term, condition, or right hereunder and shall not affect Seller's right to insist upon strict performance and compliance with regard to any unexecuted portions of this contract or future performance of these terms and conditions.

All orders must be accepted by an authorized employee of Seller. The rights and duties of the parties and construction and effect of all provisions hereof shall be governed by and construed according to the internal laws of the State of Texas. Any disputes which arise under this agreement shall be venued in the District Court of Harris County, Texas or in the Southern District of Texas.

TRADE MARK INFORMATION

References in this catalog to registered trademarks or product designations, which are owned by Cooper Cameron Corporation are as follows:

Cameron®
 Demco®
 DynaCentric®
 DynaSeal®
 Foster
 General Valve®
 NAVCO
 Nutron™
 Orbit®
 Pow-R-Seal®
 Saf-T-Seal®
 TBV™
 Techno™
 Thornhill Craver™
 TruSeal®
 Unibolt
 W-K-M

References in this catalog to registered trademarks or product designations, which are not owned by Cooper Cameron Corporation are as follows:

Trademark	Owner
Celcon	Hoechst Celanese Corporation
Delrin	E.I. DuPont De Nemours & Company
Fluorel	Minnesota Mining and Manufacturing Company
Hastelloy	Haynes International, Inc.
Hycar	Hydrocarbon Chemical and Rubber Company
Hydrin	Zeon Chemicals USA, Inc.
Hypalon	E.I. DuPont De Nemours & Company
Inconel	INCO Nickel Sales, Inc.
Monel	INCO Alloys International, Inc.
Nordel	E.I. DuPont De Nemours & Company
Stellite	Stoody Deloro Stellite, Inc.
Teflon	E.I. DuPont De Nemours & Company
Viton	E.I. DuPont De Nemours & Company