

Solenoid valves 6240



Solenoid valve 6240

The compact power valve

Gases, drinking water, hot liquids and steam are the application focuses of the type 6240 piston valve. The body, seals and design were selected in accordance with the required certificates and general requirements.

The piston solenoid valve 6240 combines the advantages of a servo-controlled and a direct-acting valve. It is suitable for both high pressures and large diameters. The fixed coupling between the pilot valve and piston of the main seat ensures complete opening even without differential pressure. The advanced piston design and optimal fluidic geometry allow surprisingly good flow rates even with small diameters.

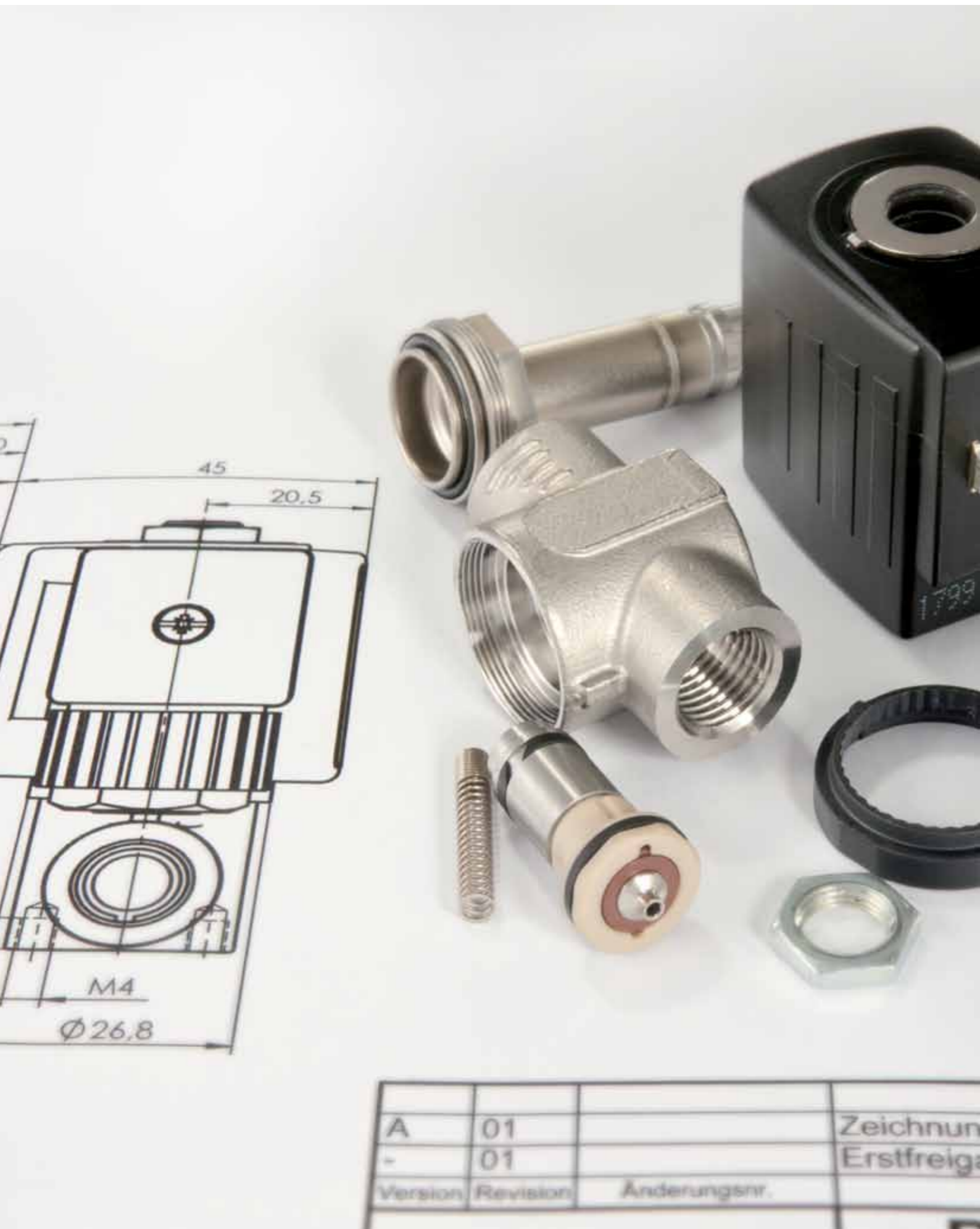

6240 Piston system with stainless steel body

Overview of versions and properties

The material and construction form the basis for a valve's reliability and safe operation. Especially fuel gases and steam place high requirements on the materials used. The 2/2-way piston valve type 6240 features a large selection of tested materials. This makes it possible to adapt the valve to specific applications.

The following versions are available:

- Pressure range: 0 to 25 bar for liquids (up to 40 bar for gaseous media)
- Media temperature: -40 to +180 °C
- Sealing materials: FKM, EPDM, PTFE, PTFE/PEEK
- Slide ring bearing
- Diameters: DN 6 and DN 12
- Body material: brass, stainless steel (316 l)
- Process connections: 1/4, 3/8, 1/2 in G, NPT
- Max. Kv value: 2.2 m³/h



Brass body

Stainless steel body

Versions optimized for applications are also available, in addition to certifications, facilitating the choice of the right valve. The following table provides an overview.

Certifications:	Certificates:	Options:
ATEX	FDA compliant	Up to 40 bar
IEC EX	Drinking water KTW + W270	Nominal diameter DN 12
UL (in preparation)	BAM	Up to +180 °C
CSA (in preparation)		Steam version
DVGW		Slide ring bearing

6240 with epoxy O-ring sealed coil

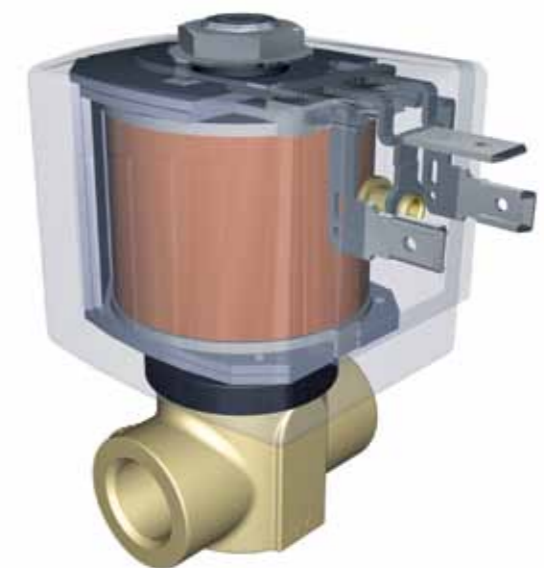

The positive thermal conductivity of the epoxy coating of the coil increases operational reliability in a 100 % duty cycle.

Functioning principle

Spring-coupled piston valve

The anchor of the pilot valve is firmly connected by a spring to the piston of the main valve. The spring-coupling ensures that a force is exerted directly on the piston when the valve is switched on, causing the main valve to open. Even without differential pressure this force is sufficient to open the valve completely. At a high differential pressure the switching of the valve is determined essentially by the characteristics of the servo valve. In this case the differential pressure supports the opening behaviour of the main valve. This technology ensures reliable opening of the valve throughout the entire pressure range.

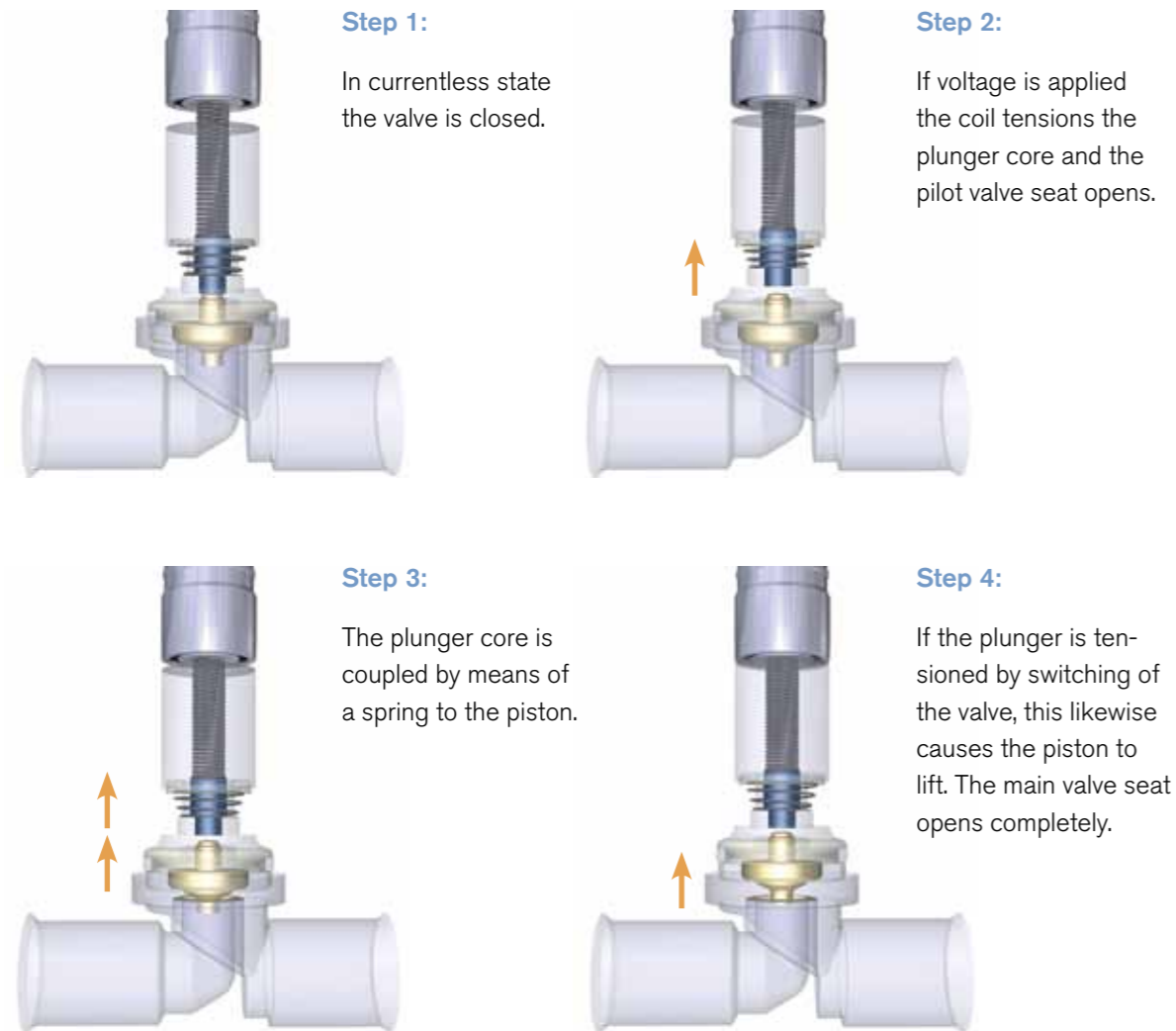

Due to its moment of inertia the spring acts as a coupling and allows successive and gentle opening and closing. Combined with a slide ring bearing, this provides for a long service life.

Sample applications

Steam applications

With a stainless steel body and PTFE as the seal material the type 6240 is the ideal solution for applications with steam and hot liquids.

Such applications include washing systems, high-pressure sterilization equipment up to 6 bar or coffee makers.



Gases and liquids

The type 6240 can be used for many different applications. For example, it is suitable for filling and emptying gas systems, as well as controlling slightly aggressive liquids. Certifications in accordance with KTW and W270 are available for drinking water applications.

Applications in this sector include fire extinguishing and distillery systems, gas supply and water treatment facilities, as well as temperature control technology.

Pharmaceutical and chemical lab applications

Test labs use a diverse range of ultra-pure gases for analysis purposes. They are stored in bottles and reduced to a delivery pressure of 8 to 25 bar by a pressure reducer for supply to the test equipment. The type 6240 is ideal for such applications due to its media-resistant materials such as stainless steel and PEEK / PTFE.



Features and benefits

Fluidic design and robust construction

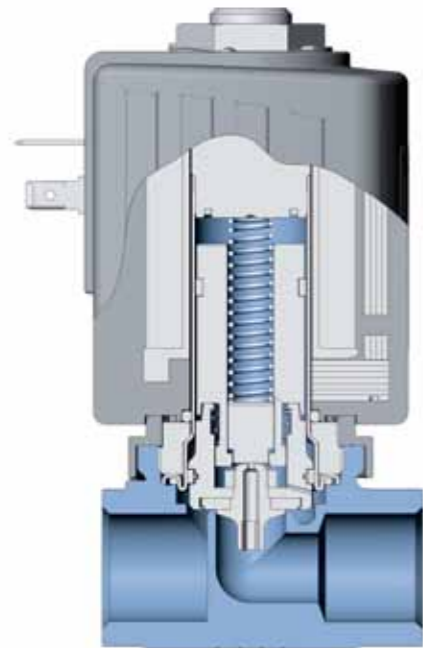

Highly durable and resistant

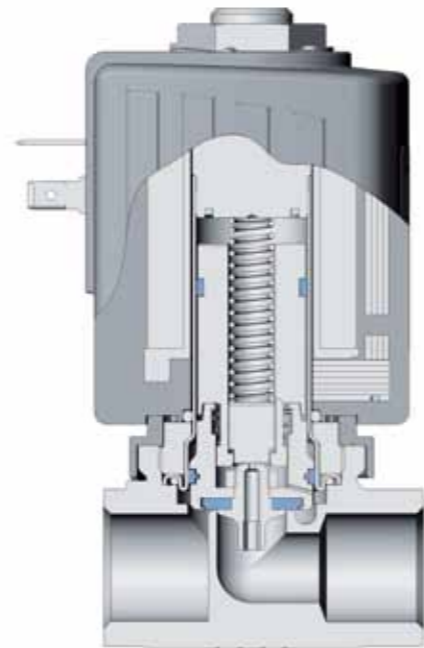

Effective explosion protection

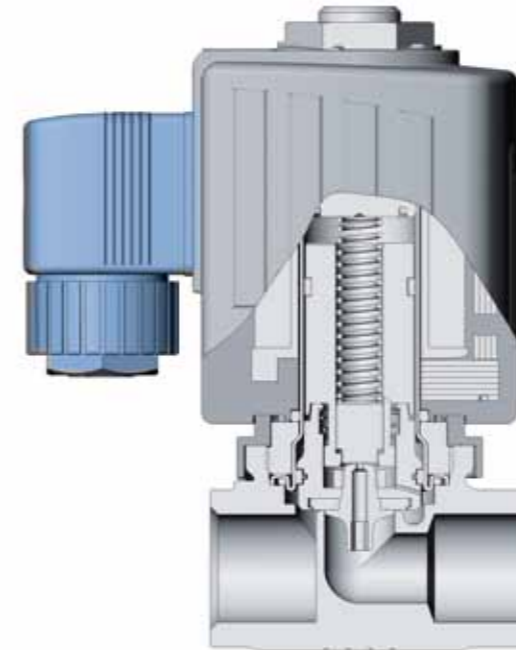

Compact and highly efficient



Body variants and pressure ranges

The brass version of the valve is suitable for controlling liquids and gases. The special fluidic form (ramp design) of the valve body enables maximum flow rates. The stainless steel version allows use in slightly acidic and alkaline solutions.

The wall thicknesses and high-quality PEEK/PTFE packing of the valve 6240 make it possible to switch at operating pressures of up to 40 bar (gaseous) and 25 bar (liquid).

Dry gases, steam and hot oils

For applications in gases the device is available with PTFE sliding rings, which ensure low-wear operation and long maintenance intervals even when used with dry gases. The "oil and grease-free" version can be used in oxygen applications.

The high-quality PTFE/PEEK packing, in combination with the stainless steel body, offers reliable functionality at steam and oil temperatures up to +180 °C.

Explosion protection

The Ex versions of the coil system (AC10, AC19-K, AC19-L) are suitable for use in areas with explosive gas-air mixtures and dust-air mixtures in Zone 1. The electrical connection is encapsulated for this purpose. The plug is not detachable. The electrical connection is established by means of the moulded cable.

As an alternative connection, a version is available with a terminal connection box AC10 for diameter DN 6.

Compact power bundle

The especially compact design of the fixed-coupling piston system (see page 6) in combination with the time-tested coil systems AC10 and AC19 make the type 6240 valve a compact power bundle, despite the low electric power consumption.

In addition, connector plugs are available for electrical over-excitation and/or power reduction (Kick and Drop).

The product spectrum at a glance

Version	Body material	Orifice [mm]	Port connection	Coil size [mm]	Pressure range [bar]		Kv value water [m³/h]	Voltage / frequency			Power consumption					Response time		Body material	Version																
					Liquid media	Gaseous media		24/DC	24/50	230/50	Inrush AC [VA]	Operation AC [VA]	Operation AC [W]	Warm coil DC [W]	Cold coil DC [W]	Open [ms]	Close [ms]																		
Standard (FKM seal, media temperature -10 to +140 °C)	Brass	6	G 1/4	32	0 - 16	0.6	X	X	X	32	18	8	10	12	20	50	Brass	Standard (FKM seal, media temperature -10 to +140 °C)																	
			NPT 1/4				X	A	A																										
			G 3/8				X	X	X																										
			NPT 3/8				X	A	A																										
	Stainless steel	6	32	G 1/4	0 - 16	0.6	X	X	X	32	18	8	10	12	20	50			Stainless steel	Standard (FKM seal, media temperature -10 to +140 °C)															
				NPT 1/4			X	A	A																										
				G 3/8			X	A	A																										
				NPT 3/8			A	A	A																										
Stainless steel	12	42	G 1/2	0 - 16	2.2	X	X	X	105	37	16	16	21	40	100	Stainless steel	Standard (FKM seal, media temperature -10 to +140 °C)																		
			NPT 1/2			A	A	A																											
			High temperature and steam (PTFE/PEEK seal, media temperature -40 to +180 °C)			6	32	G 1/4										0 - 16			0.6	X	X	X	32	18	8	10	12	20	50	Stainless steel	High temperature and steam (PTFE/PEEK seal, media temperature -40 to +180 °C)		
								NPT 1/4														A	A	A											
G 3/8	X	X		X																															
NPT 3/8	A	A		A																															
High temperature and steam (PTFE/PEEK seal, media temperature -40 to +180 °C)	12	42	G 1/2	0 - 16	2.2	X	X	X	105	37	16	16	21	40	100			Stainless steel	High temperature and steam (PTFE/PEEK seal, media temperature -40 to +180 °C)																
			NPT 1/2			A	A	A																											
			High pressure (PTFE/FKM seal, media temperature -10 to +140 °C)			Brass	6	G 1/4								40	0 - 25			0 - 40	0.6	X	X	X	40	23	10	12	14	20	50			Brass	High pressure (PTFE/FKM seal, media temperature -10 to +140 °C)
								NPT 1/4														A	A	A											
G 3/8	X	X		X																															
NPT 3/8	A	A		A																															

x = available in standard version
A = available on request

Accessories: Connectors

The connectors 2508 and 2509 are available as accessories supplement and expand the application spectrum of the solenoid valve. Besides visualization of the switching state and various standard functions, an energy-saving reduced power version (2508 LR) is available for extended duty cycles.

Without circuitry, 2-pin + protective conductor

Voltage	Constant current	Order no. without cable
0 to 250 V/AC/DC	max. 6 A	008 376
Technical data		Order no.
with conduit threads		137 943



With rectifier and varistor

Voltage	Constant current	Order no. without cable
12 to 240 V/AC/DC	max. 1 A	008 374

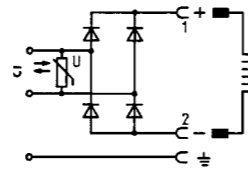

With LED

Voltage	Constant current	Order no. without cable	Order no. 3 m cable
12 to 24 V/AC/DC	max. 6 A	008 360	783 575
100 to 120 V/AC/DC	max. 6 A	008 361	-
200 to 240 V/AC/DC	max. 6 A	008 362	783 577

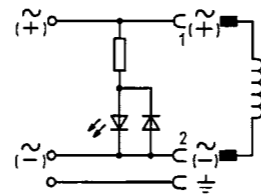

With LED and varistor

Voltage	Constant current	Order no. without cable	Order no. 3 m cable
12 to 24 V/AC/DC	max. 6 A	008 360	783 579
100 to 120 V/AC/DC	max. 6 A	008 361	783 581
200 to 240 V/AC/DC	max. 6 A	008 362	783 583
Technical data			Order no.
with conduit threads			137 944 M
with conduit threads			137 945 N
with conduit threads			137 946 P

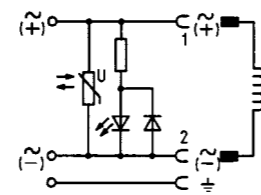

With polarity protection, recovery diode and LED

Voltage	Constant current	Order no. without cable	Order no. 3 m cable
12 to 24 V/DC	max. 1 A	008 373	783 587

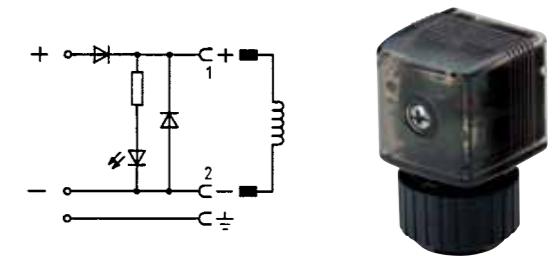

With power reduction type 2508 LR

Technical data	Order no.
Operating voltage U_{nom}	12–24 VDC Supply voltage according to IEC 364-4-41 (PELV)
Max. current	1.5 A (starting), 0.4 A (holding)
Starting power (P_{nom}) depends on valve	max. 36 W at 24 V (18 W at 12 V)
Holding power ($1/4 \times P_{nom}$) depends on valve	max. 9 W at 24 V (4.5 W at 12 V)
Over-excitation time	ca. 350 ms
Max. duty cycle LED	10/min
Off time t_{off} between two start-ups	min. 1 sec

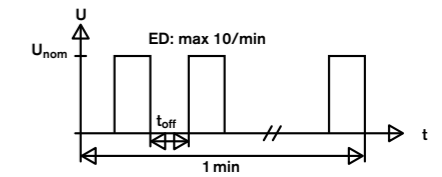

See also data sheet for type 2508

Bürkert – Close to You

For up-to-date addresses
please visit us at
www.burkert.com.



Credits: © and concept: Christian Bürkert GmbH & Co. KG | Realization: WOLF, Berlin | Photography: Münch Lichtbildneri, Stuttgart; Studio Flamisch, Düsseldorf | 3D-Drawings: 3D Sales Technologies GmbH. All people shown are employees at Bürkert. Thank you for your support (and spirit).

Bürkert Fluid Control Systems

Christian-Bürkert-Straße 13-17
74653 Ingelfingen
Germany

Tel.: +49 (0) 7940/10-0

Fax: +49 (0) 7940/10-91 204

info@burkert.com

www.burkert.com