

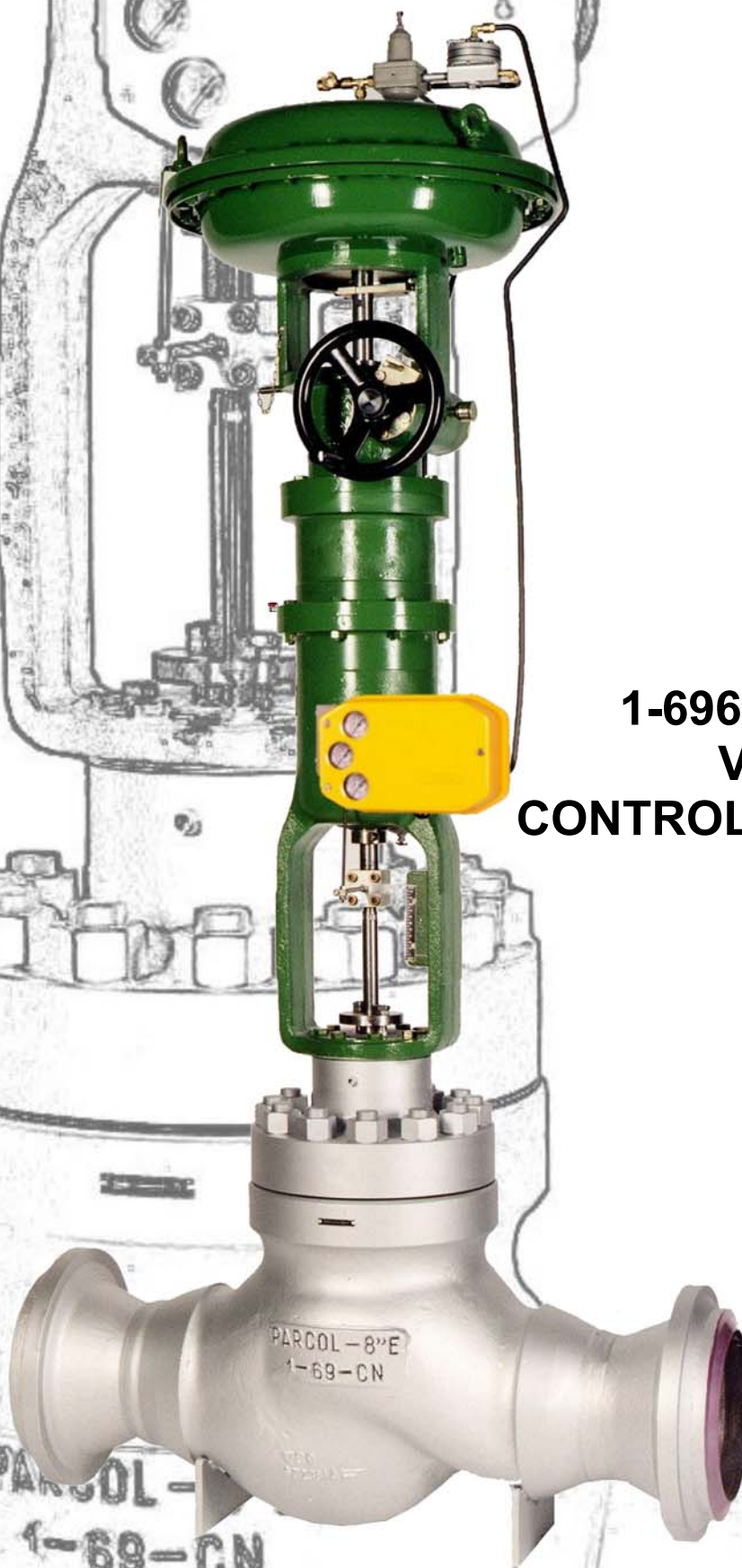

PARCOL

**1-6962 SERIES
VARISTEP
CONTROL VALVES**



1-6962 SERIES VARISTEP CONTROL VALVES

Introduction

Cavitation is a well-known phenomenon which frequently occurs when high liquid pressure drops associated with relatively high temperatures are handled in a control valve.

The microjets produced by the reversion of steam into water downstream the vena contracta are generating very high local stresses on the metal surfaces. The resulting damage appears as an extended pitting or cratering and no defence is known against this fluid impingement. Hard metals use only increases the time for destruction of the surfaces.

The ideal solution to this problem is to use a multistep trim with an appropriate pressure drop distribution to avoid or strongly limit the formation of internal vapour bubbles. This perfectly comply with the widely used Limiphon trim.

For the specific case of boiler feedwater application, two conflicting conditions have to be met with:

- 1 - protection from cavitation at low flows;
- 2 - high capacity at large flows.

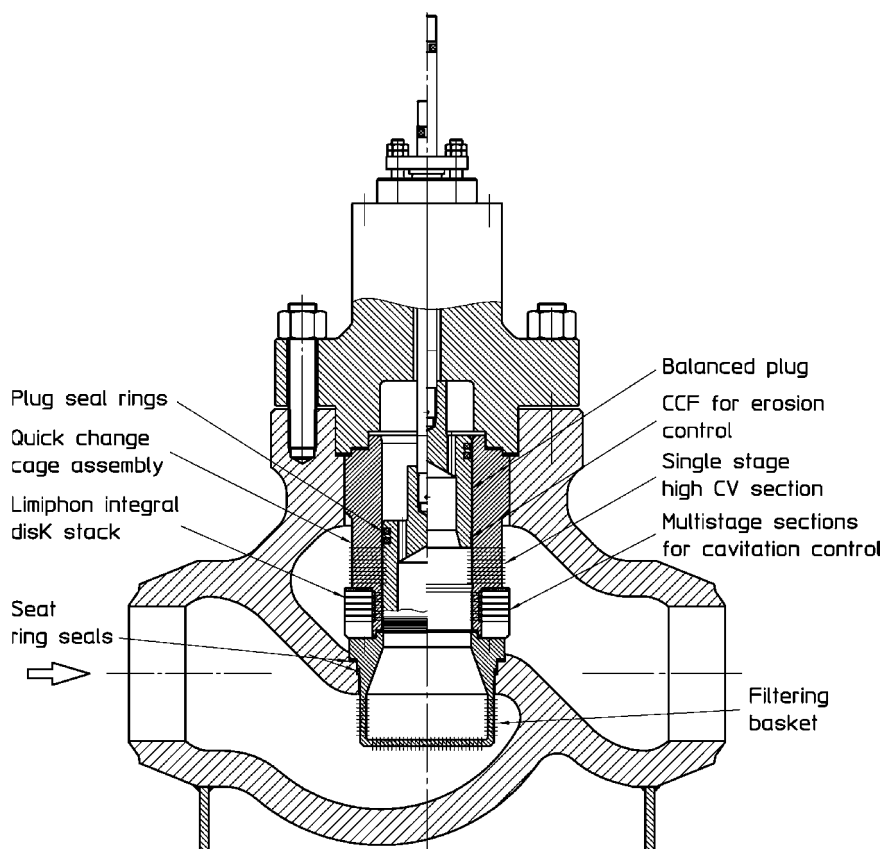

Varistep, an extrapolation of Limiphon design, has been engineered by PARCOL in order to better prevent cavitation phenomenon, without limiting the capacity at regimes not subject to cavitation.

What is new in Varistep compared with basic Limiphon design?

- 1 - radial section expansion is designed both to minimize the pressure drop at last stage (the most sensitive to cavitation) and, at the same time, to limit the pressure drop at first stage.
- 2 - less stages from bottom to top of the stack, resulting in an increase of the incremental Cv along the travel. This to comply with the pressure drop decrease at high flow rates, usually occurring in boiler feed water applications where the cavitation control is needed on not more than 20% to 30% of rated capacity.
- 3 - the stack disks are welded together to form a solid, rugged unit and an internal cage is fitted around the plug to ensure the best guiding and clearance control.
- 4 - the plug end close to the seating surface is labyrinth-shaped (CCF design) to provide the best pressure distribution in the clearance flow passage between plug and cage. This to prevent damage at the seat and on guiding surfaces.
- 5 - the design of Varistep trim leads to a double protection against huddling due to **dirty fluids** which can affect the application of some multistep trims. This is accomplished by two measures :
 - the assembly of a filter upstream the seat whose mesh complies with the flow passage of trim sections
 - in parallel-distribution of multistage part of trim and the single stage section (not sensitive to huddling) which can itself control more than the 80% of max flow rate.

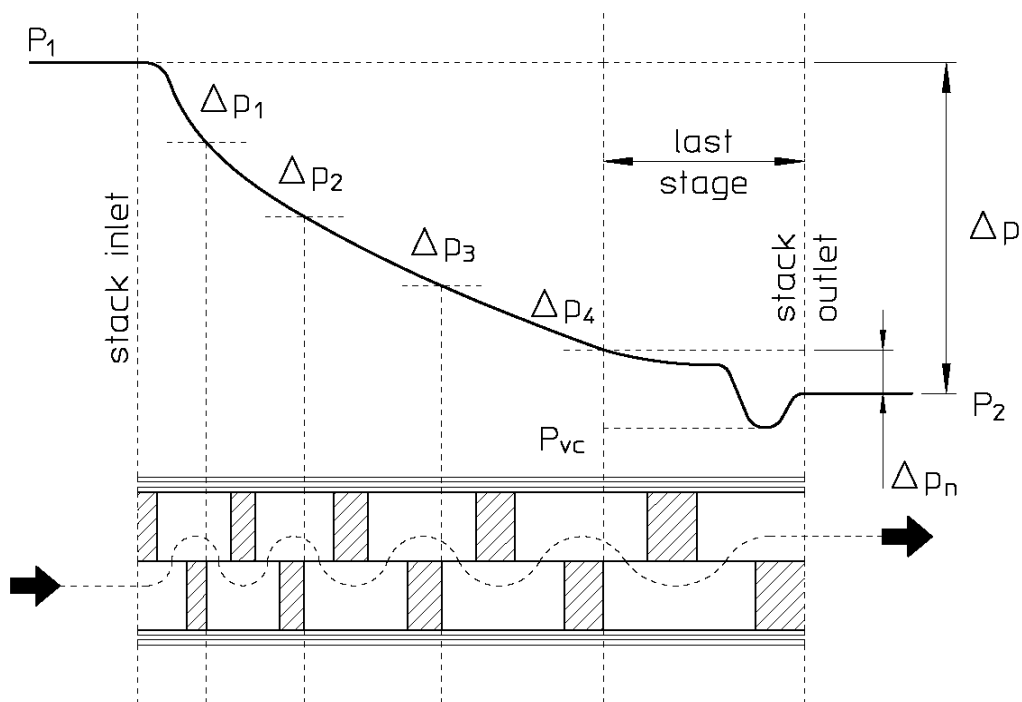

Fig. 1 - Pressure profile inside a Varistep disk stack: compared to high total Δp the individual pressure drops are low and the corresponding cavitation index $x_F = \Delta p / p_1 - p_v$ is greatly reduced.

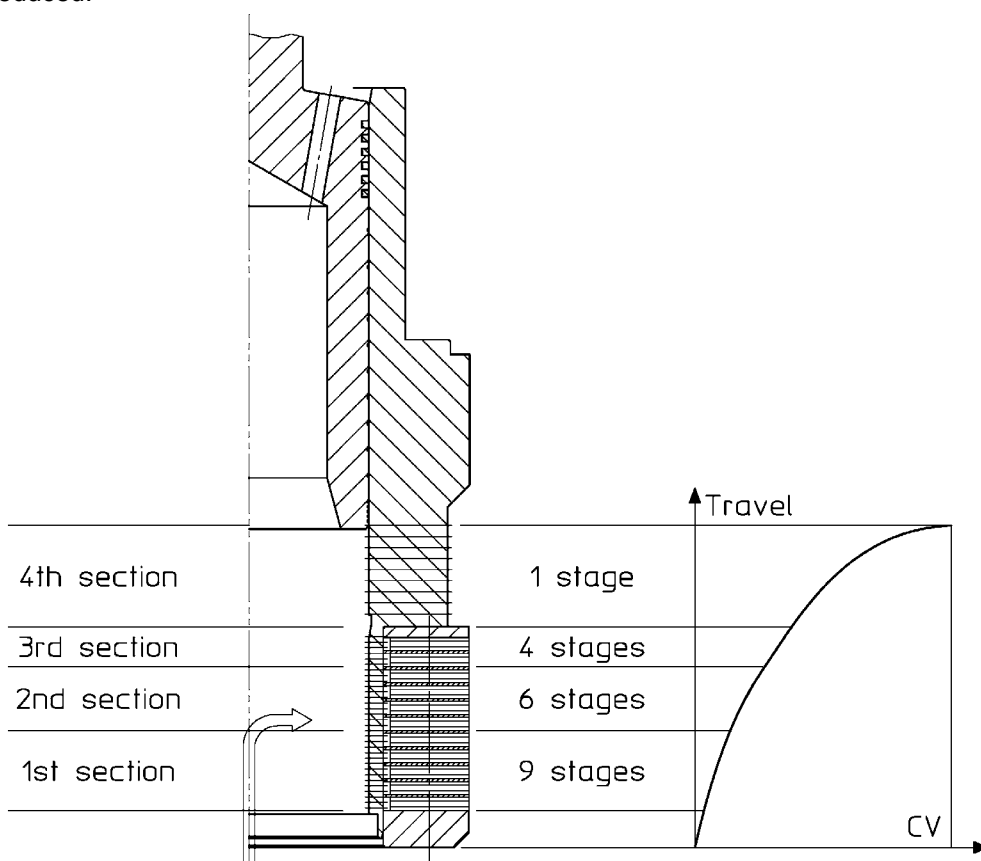

Fig. 2 - Three sections with different staging are provided, to minimize pressure recovery at low flow rates, where the Δp is high, without limiting the maximum valve flow capacity. The intrinsic flow characteristic shows a modified percentage shape which allows smooth and stable flow control near the closed position.

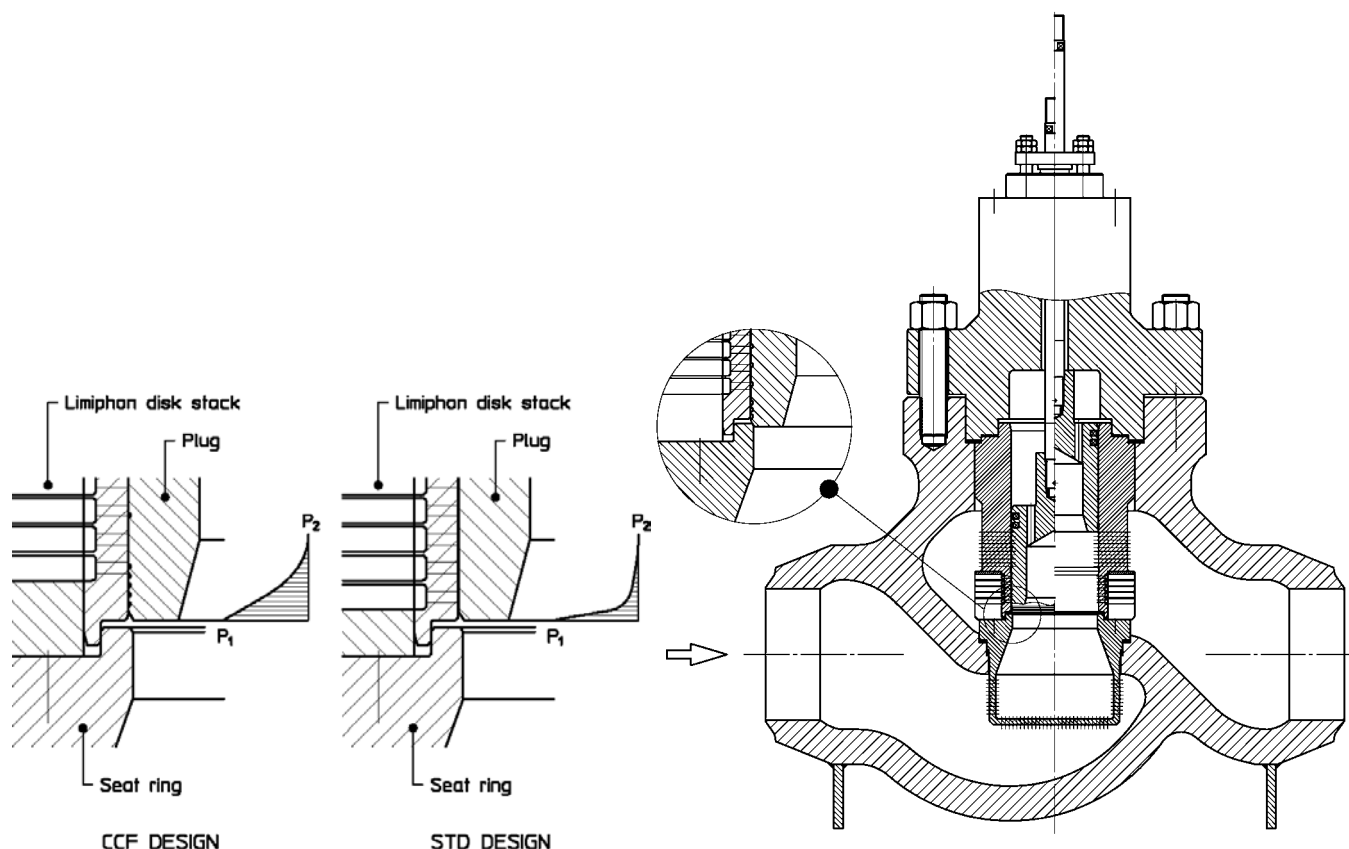

Fig. 3 - CCF labyrinth design modifies the pressure profile through the clearance flow passage avoiding abrupt pressure drops close to seating surfaces .

Technical features

body

- straight-way globe same as 1-6933 series – cast construction with bolted bonnet
- available sizes: 3" through 16".
ratings: ANSI 150÷2500 for sizes up to 12" – ANSI 150÷1500 for DN 16" for 10" and 12".
- connections: flanged and butt welding.

trim

- quick change design including drilled cage, welded or solid Limiphon stack, seat ring with integral drilled basket, CCF shaped plug.

flow direction

- flow-to open.

max temperature

- 350°C.

max differential pressure

- 200 bar (up to 10% of rated Cv) with downstream pressure 1 bar above vapour pressure;
- 350 bar in closed position.

materials

- Trim materials and body material availability are reported on material classes tables. When CrMo valve has to be fitted in carbon steel piping, transitional pieces (or reducers) made of carbon steel can be supplied welded to the valve body;
- Limiphon stack is made of AISI 304 or X19CrMoVNb11.1 accordingly to working conditions.

leakage class sealing classes IV, IVS1 and V according to IEC 60534-4 are available both for balanced and unbalanced plugs (see plug inserts summary table for more details).
 Special metal-to-metal drop-tight class equivalent to IEC class VI is available up to 2" port included (not balanced plug)

Sizing

Standard IEC sizing equations for incompressible fluids can be used to calculate valve Cv for extreme service conditions (p₁ over 200 bar and/or T₁ over 200°C) a preliminary check of non critical conditions at low flow rates must be carried out using recovery factors F_L listed in Cv table:

$$\Delta p < F_L^2 \cdot (p_1 - F_F \cdot p_v)$$

in Varistep applications only turbulent flow under normal flow condition is usually applicable and the piping geometry effect is negligible (F_p=1) so the following simplified equation can be used:

$$Cv = q_m / 865 \cdot \sqrt{\Delta p \cdot \rho_r}$$

where: q_m is the mass flow rate [kg/h]
 Δp is the pressure drop across the valve [bar]
 ρ_r is the ratio of liquid specific mass to 1000 kg/m³

To avoid significant effects of cavitation the following practical relationship can be used:

$$\Delta p / (p_1 - p_v) < F_L^3$$

STAGE				
	1 st	2 nd	3 rd	CAGE
F _L	1	0.99	0.98	0.92

Example: water T₁ = 180°C, p₁ = 180 bar, p₂ = 11 bar, p_v = 10 bar. The minimum F_L value which may prevent cavitation effects is 0.99 which is fulfilled by first section of all the Varistep trim sizes.

Special applications

For some very critical boiler start-up applications, **flashing** condition at low flow rates may occur. Varistep trim can be sized to withstand such a severe operation by a multistage velocity-controlled section. However this can be accomplished for limited flow rates involving only the first section of stack (max 10% of rated Cv). The valve sizing for this application generally leads to special trims or to oversized bodies different from those published in this bulletin.

DN <i>inc.</i>	Φ seat <i>mm</i>	port <i>inc.</i>	stroke <i>mm</i>	Cv			Cv _{max} <i>gpm</i>	Cv _{min} <i>gpm</i>	ANSI 150÷600	ANSI 900	ANSI 1500	ANSI 2500	F _L			
				1 st stage	1 st +2 nd stage	1 st +2 nd +3 rd stage							1 st stage	2 nd stage	3 rd stage	Cage
3"	38	1.1/2"	60	5.1	9.2	24	45	0.6	x	x	x	x	1.00	0.99	0.98	0.92
	28	1"	50	2.7	5.9	15.0	30	0.4	x	x	x	x				
4"	58.5	2.1/2"	76	8.1	17.7	46	95	1.0	x			x				
	47.5	2"	60	6.8	11.2	29	60	0.8	x	x	x	x				
	38	1.1/2"	60	5.1	9.2	24	45	0.6	x	x	x	x				
6"	95	4"	100	20	41	89	180	2.0	x	x	x	x				
	73.5	3"	76	13	21	58	120	1.5	x	x	x	x				
	58.5	2.1/2"	76	8	18	46	95	1.0	x	x	x	x				
8"	127	6"	165	37	77	193	365	3.4		x	x	x				
	127	6"	120		54	159	360	3.4	x							
	112	5"	100	22	40	111	240	2.9		x	x	x				
	112	5"	100		54	125	240	2.9	x							
	95	4"	100	20	41	89	180	2.0	x	x	x	x				
10"	162	8"	165	56	102	239	510	5.1	x	x	x	x				
	147	7"	165	46	90	216	450	4.7	x	x	x	x				
	127	6"	165	37	77	193	400	3.4	x	x	x	x				
12"	216	10"	200	65	146	383	775	8.2	x	x	x	x				
	186	9"	180	65	138	316	640	7.1	x	x	x	x				
	162	8"	180	56	102	274	550	5.1	x	x	x	x				
16"	216	10"	200	78	164	417	850	8.2	x	x	x					
	244	12"	225	100	192	461	950	9.5	x	x	x					
	266	13"	250	104	201	533	1100	10.4	x	x	x					

MATERIAL CLASSES

ITEM	PART NAME	CLASS A	CLASS D
1	BODY	ASTM A216 WCB	ASTM A217 WC9
2	BONNET	ASTM 105	
3	STUD	ASTM A193 B7	
4	NUT	ASTM A194 4	
6	SEAT	AISI 316 Stellite	
7	STEM	AISI 316	
8	GASKET	AISI 321 + graphite	
12	PIN	AISI 304	
14	GASKET	AISI 321 + graphite	
32	SEAL RING	reinforced PTFE	
37	SEAL RING	reinforced PTFE	
41	"C"-SEAL RING	reinforced PTFE ⁽¹⁾ (if any)	
42	SCREWED RING	AISI 304	
48	BACK-FILLER	EXPANDED GRAPHITE (if any)	
56	CAGE	A182 F6NM nitrided	

⁽¹⁾ Inconel X750 over 250°C.

⁽²⁾ AISI 304 can be replaced by AISI 316 without notice.

⁽³⁾ Selection may also depend on other sizing quantities (pressure drop, process fluid, etc.).

Port size	PLUG - item 5	
	up to IEC class IVS1	IEC class V
1" ÷ 4"	AISI 440 hardened	
5" ÷ 13"	A182 F6NM Nitrided	A182 F6NM Stellite

IEC Sealing class	SEAL RING item 49
CLASS IV	ASTM A439 D3
CLASS IVS1	CARBON GRAPHITE

FLUID TEMPERATURE ⁽³⁾	DISK STACK item 50
up to 250°C	AISI 304 ⁽²⁾
over 250 °C	X19CrMoVNb11.1

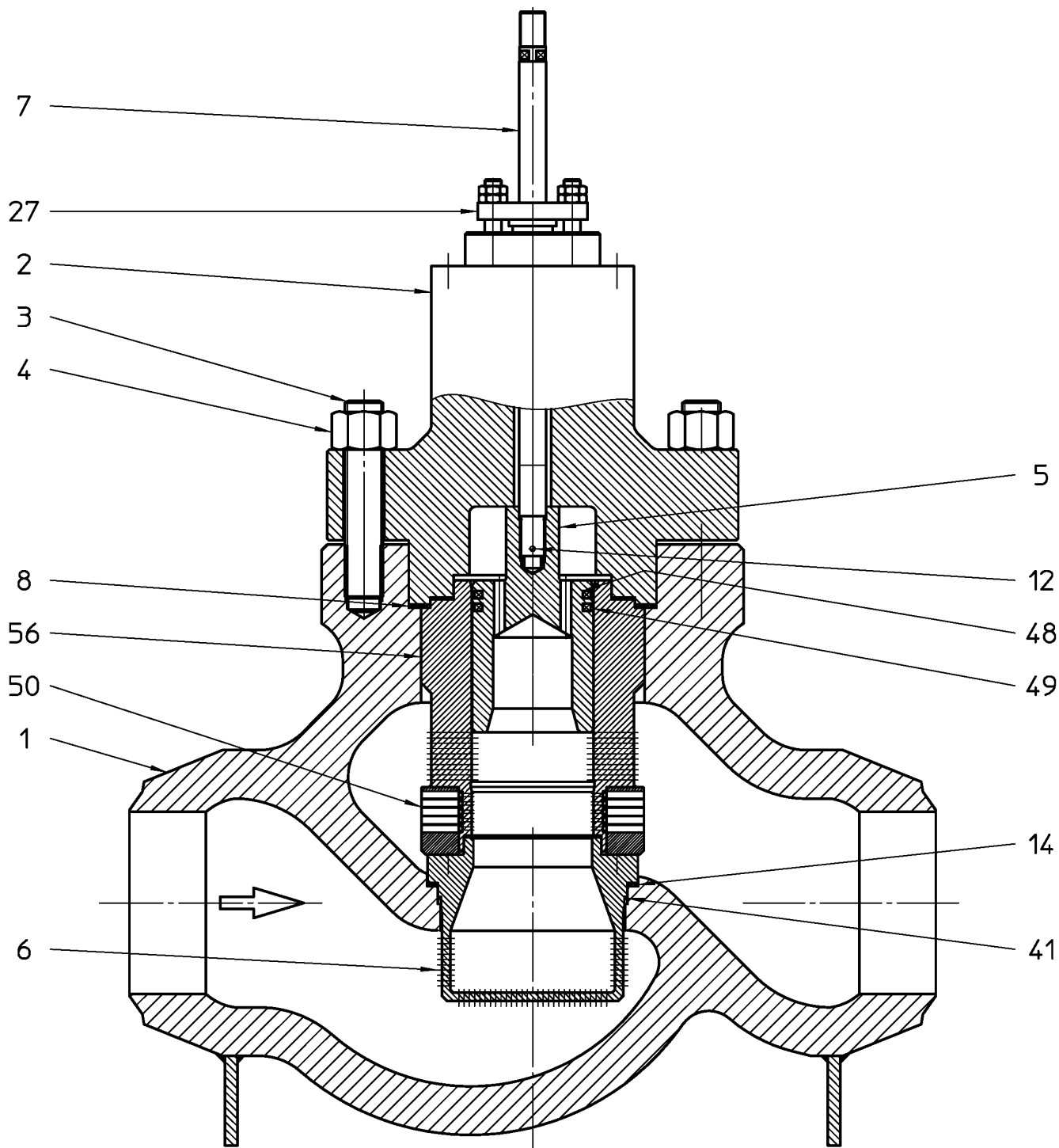

ITEM	PART NAME	ITEM	PART NAME
1	BODY	12	PIN
2	BONNET	14	GASKET
3	STUD	27	PACKING BOX
4	NUT	41	"C"-SEAL RING
5	PLUG	48	BACK-FILLER
6	SEAT	49	SEAL RING
7	STEM	50	LIMIPHON DISK STACK
8	GASKET	56	CAGE

PRESSURE / TEMPERATURE RATINGS FOR BALANCED PLUG

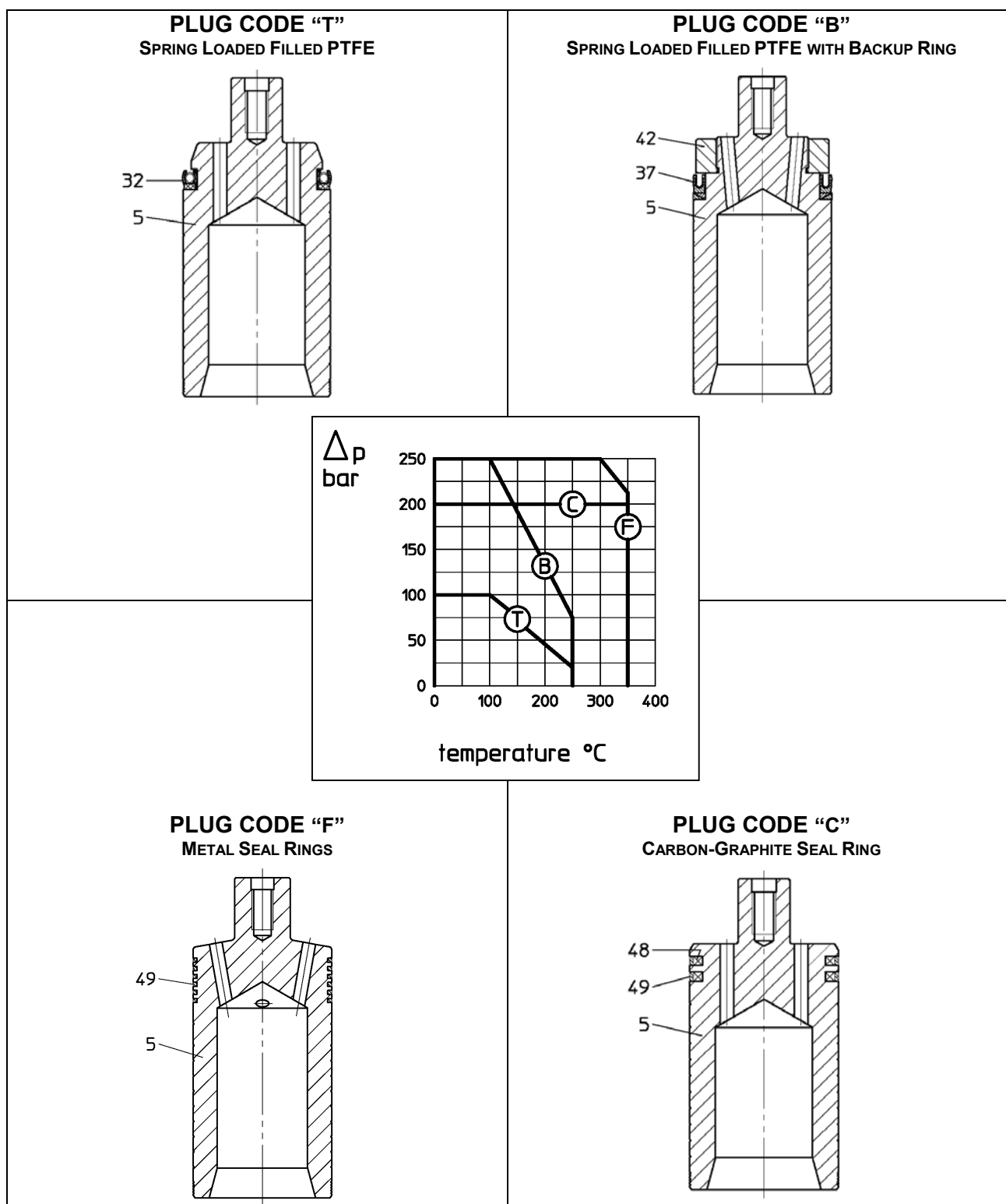

PLUG INSERTS SUMMARY TABLE

Port size	IEC Sealing class	Rating	Description	Code
2" ÷ 13"	V	ANSI 150÷600	Spring loaded filled PTFE seal ring	T
1" ÷ 13"	V	ANSI 900÷2500	Spring loaded filled PTFE seal ring with backup ring	B
1.½" ÷ 13"	IV S1	ANSI 150÷2500	Carbon-graphite + Expanded Graphite	C
2" ÷ 13"	IV	ANSI 150÷2500	Metal seal rings	F

OVERALL DIMENSIONS - mm

FLANGED BODY

DN	A ^{(1) (2)}											
	ANSI 150 RF	ANSI 150 RJ	ANSI 300 RF	ANSI 300 RJ	ANSI 600 RF	ANSI 600 RJ	ANSI 900 RF	ANSI 900 RJ	ANSI 1500 RF	ANSI 1500 RJ	ANSI 2500 RF	ANSI 2500 RJ
3"	298	311	317	334	337	340	441	444	460	463	660	666
4"	352	365	368	384	394	397	511	514	530	533	737	747
6"	451	464	473	489	508	511	714	717	768	774	864	877
8"	543	556	568	584	610	613	781	784	838	848	1022	1038
10"	673	686	708	724	752	755	864	867	991	1001	1270	1292
12"	737	750	775	791	819	822	1016	1019	1130	1146	1575	1597
16"	1016	1029	1057	1073	1108	1111	1422	1431	1422	1444	--	--

BW ENDS BODY

DN	A ⁽¹⁾					
	ANSI 150	ANSI 300	ANSI 600	ANSI 900	ANSI 1500	ANSI 2500
3"	337	337	337	460	460	498
4"	394	394	394	530	530	575
6"	508	508	508	768	768	819
8"	610	610	610	832	832	1029
10"	752	752	752	991	991	1270
12"	819	819	819	1130	1130	1422
16"	1108	1108	1108	1422	1422	--

1) ANSI 150 dimensions also apply to PN 10, 16
 ANSI 300 dimensions also apply to PN 25, 40
 ANSI 600 dimensions also apply to PN 63, 100

2) Tolerance on face-to-face "A" dimensions:
 ± 2 mm for body sizes up to 10"
 ± 3 mm for body sizes 12" and over

DN	PORT	TRAVEL mm	DIAPGRAGM ACTUATOR	B						C ⁽¹⁾		
				ANSI			ANSI		ANSI	ANSI	ANSI	ANSI
				150	300	600	900	1500	2500	150÷600	900-1500	2500
3"	1.1/2"	60	D 450	120	120	125	140	140	130	317	322	380
			D 600	120	120	125	140	140	130	317	322	380
	1"	50	D 450	120	120	125	140	140	130	286	289	390
			D 600	120	120	125	140	140	130	286	289	390
4"	2.1/2"	76	D 600	135	135	140	160	160	153	364	370	450
			60	D 450	135	135	140	160	160	153	315	351
	D 600	135		135	140	160	160	153	315	351	435	
	D 450	135		135	140	160	160	153	323	348	421	
	D 600	135		135	140	160	160	153	323	348	421	
	6"	4"	100	D 63	167	170	185	195	205	230	447	510
3"		76	D 600	167	170	185	195	205	230	382	455	474
				167	170	185	195	205	230	382	455	474
8"	6"	165	D 63				250	260	290		707	730
		120		193	198	220			487			
	100	4"		193	198	220	250	260	290	475	596	664
		5"		193	198	220	250	260	290	475	570	638
10"	8"	165	D 63	225	230	260	290	320	350	599	707	700
	7"			225	230	260	290	320	350	599	707	700
	6"			225	230	260	290	320	350	599	707	700
12"	10"	200		270	275	307	320	350	433	725	750	780
	180	9"		270	275	307	320	350	433	653	730	780
		8"		270	275	307	320	350	433	653	730	780
16"	13"	250	C450	378	378	390	450	450		900	950	
	12"	225		378	378	390	450	450		900	950	
	10"	200	D 63	378	378	390	450	450		900	950	

⁽¹⁾ Plain Bonnet

PNEUMATIC ACTUATORS

ACTUATOR TYPE	D	E ⁽¹⁾		MASS – kg ⁽¹⁾	
		DIRECT	REVERSE	DIRECT	REVERSE
Diaphragm - 1-X-210 D450 Stroke 50-60 mm	482	584	750	48	63
Diaphragm - 1-X-210 600 Stroke 50-60-76 mm	631	745	954	98	130
Diaphragm - 1-X-250 D63 Stroke 100-120 mm	640	985	1022	185	215
Diaphragm - 1-X-250 D63 Stroke 165-180-200 mm	640	1370	1407	220	250
Cylinder - 1-X-400 C450 Stroke 225-250 mm	575	1350	1500	360	360

⁽¹⁾ Without manual operator

BW END VALVES

DN	MASS - kg					
	ANSI 150	ANSI 300	ANSI 600	ANSI 900	ANSI 1500	ANSI 2500
3"	60	60	65	80	85	170
4"	90	90	95	95	125	290
6"	180	180	185	265	300	690
8"	230	230	350	495	710	1100
10"	460	460	550	600	900	1270
12"	670	670	710	1000	1400	3100
16"	1610	1610	1950	2600	3100	--

FLANGED VALVES

DN	MASS – kg					
	ANSI 150	ANSI 300	ANSI 600	ANSI 900	ANSI 1500	ANSI 2500
3"	65	70	90	120	135	220
4"	95	105	140	145	180	370
6"	150	180	225	330	440	930
8"	270	300	400	680	900	1380
10"	450	540	690	800	1200	2200
12"	650	740	960	1275	1850	3950
16"	1830	1830	2200	3500	4000	--

