



CCI in Oil and Gas Production Transportation Processing Petrochemical

By Sam Sturtevant, P.E. Marketing Analyst

**22591 Avenida Empresa
Rancho Santa Margarita, CA 92688
949.858.1877 • Fax 949.858.1878 • ccivalve.com**

428 | 03/01 • ©2000 CCI • DRAG is a registered trademark of CCI.

CCI in Oil and Gas

■ By Sam Sturtevant, P.E. Marketing Analyst - Oil & Gas, CCI

Plant Types

CCI Production

- Oil Production
- Gas Production
- GOSP

CCI Transportation

- Gas Transportation
- Gas Storage
- Liquids Transportation

CCI Processing

- LNG Production
- Gas Processing

CCI Petrochemical

- Ethylene
- Ammonia
- Refinery

Overview

CCI DRAG Valve technology has advanced along with the Oil & Gas industry. Quick stroking requirements for compressor recycle have reached one second or less using low cost, highly reliable pneumatic actuation. This is a major trademark advantage of CCI Control Valves. Hydraulic actuation has been used but is not favored due to high maintenance, reliability and high cost.

CCI's balance seal is unique in the industry. This design clamps the seal in the bonnet, which is superior to manufacturers who use the balance seal in a groove on the plug. The resulting benefit is that the balance seal remains effective at cryogenic temperatures as the seal shrinks to form a better plug seal, while the competitors plug seal shrinks and moves away from the cage impairing sealing.

For gas to flare valves, tight shutoff has ensured that product or feedstock has not been unnecessarily flared. A minimum of Class V shutoff and frequently Class VI shutoff has been applied successfully for this application.

CCI was a leader in the development of IEC 534. We were one of the first to recognize a noise increase in the expansion section of a control valve applied for noise control. Acceptable noise levels below 85 dBA have been met through CCI's severe service installations globally.

CCI can assist in Selection of Severe Service valve applications, to ensure low ownership costs. CCI can lower installed cost due to smaller pipe sizes, and reduce parallel valve installation due to high valve rangeability. For example, in compressor recycle, a startup ball valve may be in parallel to the recycle valve. However, CCI can add this application requirement into the compressor recycle application, saving the client installation costs.

To summarize, Severe Service applications are critical for low noise, protection of major equipment components, minimizing loss of product or feedstock, increase compressor efficiency, and ensuring high plant reliability and efficiency. CCI engineers can review systems and apply proven solutions to lower installed cost. CCI has proven references installed in over 50% of the LNG plants globally.

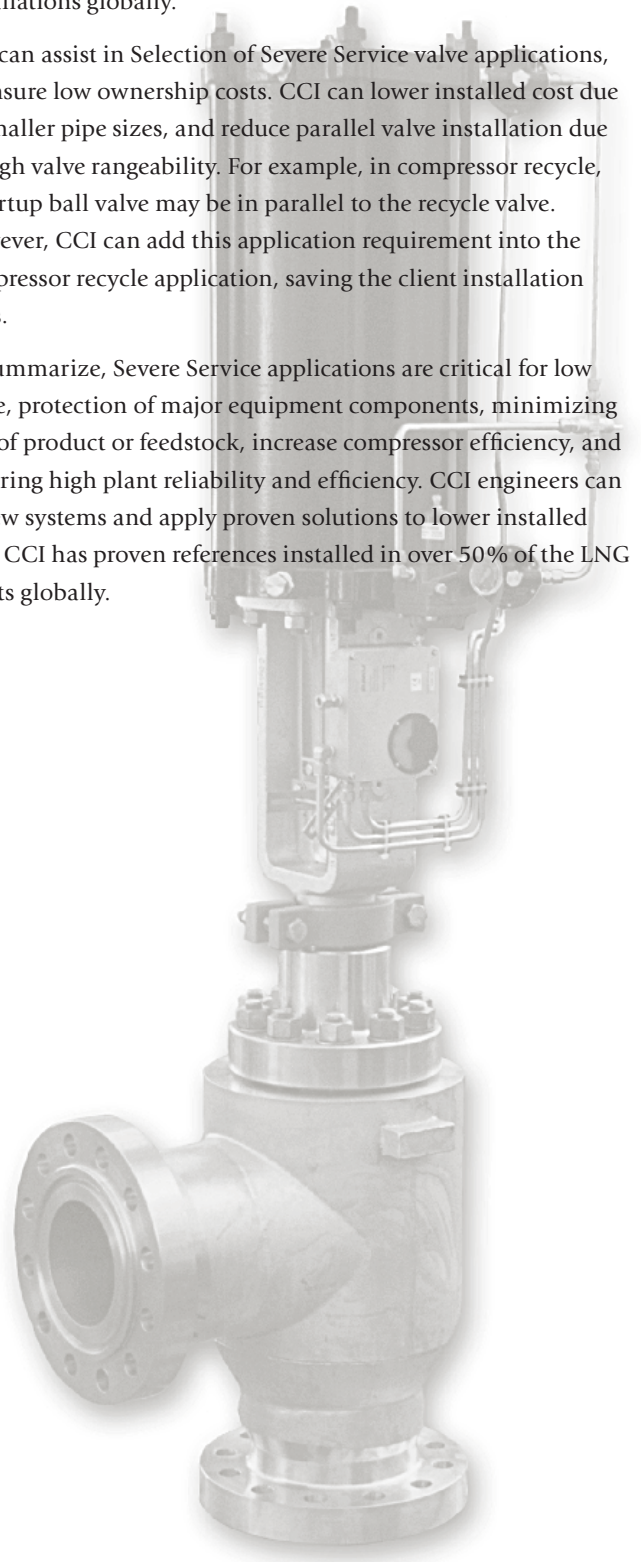

Purpose

Eliminate Unwanted Noise

High fluid velocities through the pressure letdown process will create aerodynamic noise. Controlling the fluid velocities through the letdown path to an acceptable level will ensure that noise is not created in the first place. This is called source treatment where noise is not hidden, but not created. CCI DRAG technology takes the entire pressure drop through the disk stack and attenuates the noise to the specified level without the use of downstream devices, or silencers.

Protection of Major Equipment Components

The compressor is one of the most expensive pieces of equipment for an Oil & Gas Plant. A compressor can go into surge if the flow drops below 80% of the rated flow. The CCI DRAG valve is designed to respond and open within 1 second to protect the compressor from surge flow. A good control system along with the CCI DRAG valve will provide a long life for the compressor. This has been proven by our references in other Plants around the world.

Minimize Loss of Product or Feedstock

If a gas-to-flare valve is leaking, then precious product is going to flare where it will be wasted. Repeatable, tight shutoff is absolutely necessary to ensure that product or feedstock will go where it belongs, which is to the customer, and not burned.

Increase Compressor Efficiency

Compressor Recycle valves must have repeatable tight shutoff to ensure that the compressor will have the highest efficiency. It is known that a majority of the cost of the compressor is the energy cost to run it over a period of time. This significantly outweighs the cost of the valve. When a valve is leaking, then the compressor requires more energy to meet the same throughput. This leaking inefficiency can far outweigh the costs of the valve over time, even the cost of the compressor.

Ensure High System Reliability and Efficiency

There are many components to system reliability and efficiency. These include:

- Maintain plant efficiency
- Maintain high plant throughput
- Ensure high valve and equipment reliability
- Increase plant availability.

All of these are consistent with each other. Excellent products and services ensure an excellent system that is reliable and efficient. Compromising with a lower cost inferior technical solution to save money will end up costing more money in the long run.

How can you meet the above purposes? By specifying the critical control valves important to the project at an early stage. Critical control valves heavily impact the above aspects of the plant the Owners are measuring. The valve specifications ensuring that the above requirements are met, include the Control valve Specifications based on ISA.



CCI IN OIL AND GAS PRODUCTION

Oil Production

Production

- Production Choke
- 1st Stage Separator Level Control
- 2nd Stage Separator Level Control
- Separator Pressure Control
- Gas to Flare
- Emergency Depressurizing

Injection

- Compressor Recycle
- Gas Injection
- Gas Lift
- Steam Injection
- Water Injection Pressure Control
- Water Injection Pump Recirculation
- Overboard Dump

Oil Export

- MOL Pump Reirculation
- Pressure Control
- Flow Control

Balance of Plant

- Fire Water Pump Recirculation
- Fire Water Pump Discharge

Gas Production

Production

- Production Choke
- 1st Stage Separator Level Control
- 2nd Stage Separator Level Control
- Separator Pressure Control
- Gas to Flare
- Emergency Depressurizing

Injection

- Methanol Injection

Gas Export

- Compressor Suction Throttle Control
- Gas Export Pressure Control
- Compressor Recycle

Balance of Plant

- Fire Water Pump Recirculation
- Fire Water Pump Discharge

Gas Oil Separation Plants

- 1st Stage Separator Level Control
- 2nd Stage Separator Level Control
- Separator Pressure Control
- Gas to Flare
- Emergency Depressurizing

DRAG® Valve Users in Oil & Gas Production

ARCO	ADNOC, ADCO - Abu Dhabi
ONGC - India	Saudi Aramco
British Gas	Chevron
Amoco	Phillips
Pertamina	Marathon
Exxon	Mobil
EPMI, Petronas - Malaysia	Statoil
Conoco	Amarada Hess
Oryx	Shell
ELF	Lille Frigg
BP/AMOCO	Forties & Others

DRAG® Valve Users in Offshore Oil & Gas Production

User	Facility
Exxon	Mobile Bay
Marathon	East Brae, Brae B
Mobil	Beryl B
Qatar General Petroleum Co.	North Alpha
EPMI	Guntong, Lawit A, Bekok C, Jerneh
Woodside	Goodwyn A
Chevron	Ninian, Alba
Shell	Brent
Total	Alwyn North
Statoil	Troll, Statfjord, Gulfaks, Karsto
Phillips	Ekofisk
Oryx	Murchison
Amarada Hess	Scott
Petronas Carigali	Dulang
Amoco	Leman

CCI IN OIL AND GAS TRANSPORTATION

Gas Transportation

Transportation

- Compressor Recycle
- Emergency Vent
- Inlet / Outlet Pressure Control
- Vent Resistor

Metering Stations

- Active or Master Valve
- Slave or Monitor Valve

Gas Storage

Balance of Plant

- Gas Injection
- Gas Withdrawal
- Emergency And Service Vents
- Fuel Gas Regulation Valves

Liquids Transportation

Pumping Station

- Pump Recirculation
- Export Flow Control
- PIG Launcher Pressure Control

Pressure Reducing Station

- Pressure Letdown
- Surge Relief

Liquids Terminal

- Pressure Letdown
- Metering Station
- Tanker Fill Flow Control
- Vapor Recovery System Pressure Control
- Vapor Recovery System Compressor Recycle

DRAG® Valve Users in Gas Transportation & Storage

User	Location	Facility
Transco (BG)	UK	Black Rod
Consolidated Natural Gas	Pennsylvania Finnefrock, Harrison	Leidy, Greenlick
ANR Storage	Michigan	Blue Lake
Bord Gais	Ireland	Loughshinny
Gaz de France Cuvilly, Cherre	France	Taisnieres, Manosque
People's Natural Gas	West Virginia	Rager Mountain
Rurhgas	Germany	Bierwang
Northwestern Utilities	Canada	Ft. Saskatchewan
Western Gas Resources	Texas	Katy
Arco China	China	Black Point

DRAG® Valve Users in Petroleum Transportation

User	Location	Facility
Saudi Aramco Abqaiq	Saudi Arabia	Yanbu, Safaniya
Unocal	California	Mojave
All American Pipeline Black River	California	Pentland, Cadiz
EPMI	Malaysia	Tapis
Alyeska Pipeline	Alaska	Valdez
US DOE, SPR Bryan Mound	Louisiana Texas	Bayou Choctaw, Big Hill
Marathon	UK	Brae A

CCI IN OIL AND GAS PROCESSING

LNG Production

Balance of Plant

- Feedgas Regulator
- Slug Catcher Level Control
- Amine Pump Recirculation Control
- Acid Gas Separator Level Control
- Slug Catcher/Acid Gas Separator Gas-to-Flare
- C3/MCR/BOG Compressor Anti-Surge Valve
- Hot Gas Bypass Valves
- Gas Vent to Flare
- MCR/Feedgas JT (Joule-Thomson) Valve
- Depressurizing

Gas Processing Plant

Steam System

- Turbine Bypass
- Steam Conditioning
- Steam Header Pressure Control
- Feedwater Regulator
- Feedwater Pump Recirculation
- Spraywater
- Steam Vent to Atmosphere
- Vent Resistor

Balance of Plant

- Import/Export Gas Regulation
- Compressor Anti-surge
- Hot Gas Bypass
- Process Gas to Vent/Flare
- Slug Catcher/KO Drum Level Control
- Rich Amine Letdown
- Expander Bypass (JT Valves)
- Emergency Depressurizing

CCI DRAG® Valves in LNG/NGL Facilities

- Shell Oman LNG, Trains 1 & 2
- RASGAS LNG Plant, Trains 1 & 2
- Qatar Liquefied Gas Co. LTD., Ras Laffan
- Qatar, Qatar Gas LNG Plant, Trains 1, 2, & 3
- Adgas LNG 1, 2, & 3, DAS Island
- Pertamina, P.T. Badak NGL Co., Trains A through H
- Shell International Petroleum, Brunei
- Sarawak Shell BHD., Bintulu, Malaysia, MIng-Dua Gas Inlet Facility

Drag® Valve Users in Gas Processing

User	Location	Facility
Exxon	Alabama	Mobile Bay
Mobil	Alabama	Mary Ann
	UK	St. Fergus
Petronas	Malaysia	GPP 5&6
Williams Field Service	New Mexico	La Mequina, Milagro
PEMEX	Mexico	Cactus, Nuevo Pemex
Arco	Dubai	Marghan
	China	Black Point
EPMI	Malaysia	PTG-03
Statoil	Norway	Troll
Saudi Aramco	Saudi Arabia	Abqaiq, Berri Shedgum, Uthmaniyah
Shell	Alberta, Canada	Caroline
Conoco	UK	Theddlethorpe

CCI IN OIL AND GAS PETROCHEMICAL

Ethylene

Steam System

- Turbine Bypass
- Steam Conditioning
- Steam Header Pressure Control
- Feedwater Regulator
- Feedwater Pump Recirculation
- Spraywater
- Steam Vent to Atmosphere
- Vent Resistor

Balance of Plant

- Feed Gas Flow Regulator
- Compressor Anti-surge
- Lean Amine Pump Recycle
- Rich Amine Letdown
- Expander Bypass
- Process Gas Depressuring
- Gas To Vent/Flare

Ammonia

Steam System

- Turbine Bypass
- Steam Header Pressure Control
- Feedwater Regulator
- Feedwater Pump Recirculation
- Steam Vent to Atmosphere
- Vent Resistor

Balance of Plant

- Feedstock Flow/Pressure Control
- Benefield Solution Valve
- Compressor Antisurge
- Passivation Valve
- Syngas Vent to Flare
- Air Vent

DRAG® Valve Users in Ethylene Plants

User	Location	Facility
Dow Chemical	Texas	Oyster Creek
Louisiana Ft. Saskatchewan	Plaquemine The Netherlands	Canada Terneuzen
SADAF	Saudi Arabia	Al Jubail
Lyondell Petrochemical	Texas	Channelview
Union Carbide	Louisiana	Taft
Chevron	Texas	Cedar Bayou
Phillips	Texas	Sweeney
Millennium Petrochemical	Illinois	Morris
Amoco Chemical	Texas	Chocolate Bayou
Shell	Alberta, Canada	Caroline
Conoco	UK	Theddlethorpe

DRAG® Valve Users in Petrochemical Plants

User	Location	Facility
Terra Nitrogen	Oklahoma Iowa	Woodward Port Neal
Occidental Chemical	Texas	Deer Park
Union Carbide	Louisiana	Taft
Shell Chemical	The Netherlands	Moerdijk
E.I. DuPont	Texas	Sabine River
Millennium Petrochemical Illinois	Texas Morris	La Porte
Amoco	Belgium Texas	Brouhon Chocolate Bayou
Chevron	Texas	Cedar Bayou
SADAF	Saudi Arabia	Al Jubail
Dow Chemical		Turnuezen, Ft. Saskatchewan, Plaquemine, Oyster Creek
Farmland Industries	Trinidad	Trinidad Ammonia
Sasol	South Africa	Sasol II
ICI Chemicals	UK	Wilton

CCI IN OIL AND GAS PETROCHEMICAL

CCI IN OIL AND GAS PETROCHEMICAL

Refinery

Steam System

- Turbine Bypass
- Steam Conditioning
- Steam Header Pressure Control
- Feedwater Regulator
- Feedwater Pump Recirculation
- Spraywater
- Steam Vent to Atmosphere
- Vent Resistor

Hydrocracker

- Flash Gas Relief
- Make-up Gas Compressor Recycle
- HP/HT Oil Letdown
- LP/HT Oil Letdown
- Feed Oil Surge Relief
- Vent And Pressure Control

Hydrotreater

- Recycle Gas Compressor Anti-surge
- Hot High Pressure Separator Level Control
- Cold High Pressure Separator Level Control
- Feedstock Pump Recycle
- Separator Vent And Pressure Control

H₂S/CO₂ Stripper Loop

- Rich Amine Letdown
- Lean Amine Pump Recycle
- Sour Water Letdown

Hydrogen Unit

- Process Gas To Vent/Flare
- Compressor Anti-Surge/Recycle
- Lean Amine Pump Recycle
- Rich Amine Letdown

DRAG® Valve Users in Refineries

User	Location
Chevron	Pascagoula, El Segundo
Texaco	Wilmington
Exxon	Benecia, Baton Rouge
Mobil	Torrance, Beat
Tosco	San Francisco
Arco	Carson
Amoco	Texas City
Phillips	Borger, Sween
CO-OP Refinery	Regina
Sloznaft	Bratislava
Fina	Antwerp
Agip	Livorno
Yukong	Ulsan
LG Caltex	Yeochon
Pertamina	Cilicap
Rayong Refining	Map Ta Phut
Chinese Petroleum Corp	Tao Yuan
Shell	Geelong, Pernis

