

JAKI non-lubricated and sleeved plug valve is designed for the most corrosive and severe chemical services. This plug valve contains a polymeric sleeve, which is inserted in the valve body. The tapered and polished plug acts like a wedge and presses the sleeve against the body. The PTFE sleeve has a low coefficient of friction and it acts as a lubricant to reduce friction between the plug and the body. This cavity-free design provides a tight shutoff with positive seal.

The valve can safely and efficiently handle gas and liquid fuel and can also be used as reliable on-off and throttling device in a wide variety of demanding service.

■ Product Advantage

- **Compact design**
Tapered plug with trapezoidal shaped port, one piece body construction reduces leak path.
- **Bi-directional flow**
Bi-directional inline bubble-tight seal is independent of line pressure, hence more convenient for valve installation and usage.
- **Cavity free**
There are no cavities to accumulate flow media. The plug is surrounded completely by sleeve and this is positively locked in the body.
- **No lubrication**
The PTFE sleeve has a low coefficient of friction and acts as a lubricant and facilitate operation to open or close.
- **Self-cleaning**
The 360° port lip provides the function of self-cleaning when the plug is rotated to remove scaling and adhering media.
- **Zero leakage**
With three independent sealing systems by sleeve, diaphragm and wedge ring, the valve assures effective sealing inline and to atmosphere.
- **Less maintenance**
The sealing pressure adjustment is achieved by tightening the adjustment screws to push the plug down into the sleeve.
- **Anti-static feature**
The metal diaphragm provides additional support to the metal diaphragm for positive sealing and with a unique lip design to prevent static electrical charge on the plug.
- **Fire safe design**
As a standard, the JAKI fire seal design is required to prevent external leakage in the event of a fire. Live-loaded spring washers provide a constant pressure on the cover and metal diaphragm especially after a fire.

■ General Applications

JAKI PTFE sleeved plug valve is suitable for isolation in the desalination, processing and mining industries.

- Chemical Processing
- Fertilizer
- Pulp and Paper
- Chemical Transfer
- Mineral Processing
- Organic or Inorganic Chemical
- Slurries
- Corrosive Services
- Pharmaceutical
- Chemical and Liquor
- Mining
- Polymers
- Caustic and Chlor-Alkali
- Water Handling and Treatment
- Desalination
- Coating

JAKI's standard valve line has been specifically developed to meet most applications. For specific services, JAKI offers appropriate valve and materials to meet these needs.

Valve Design Features

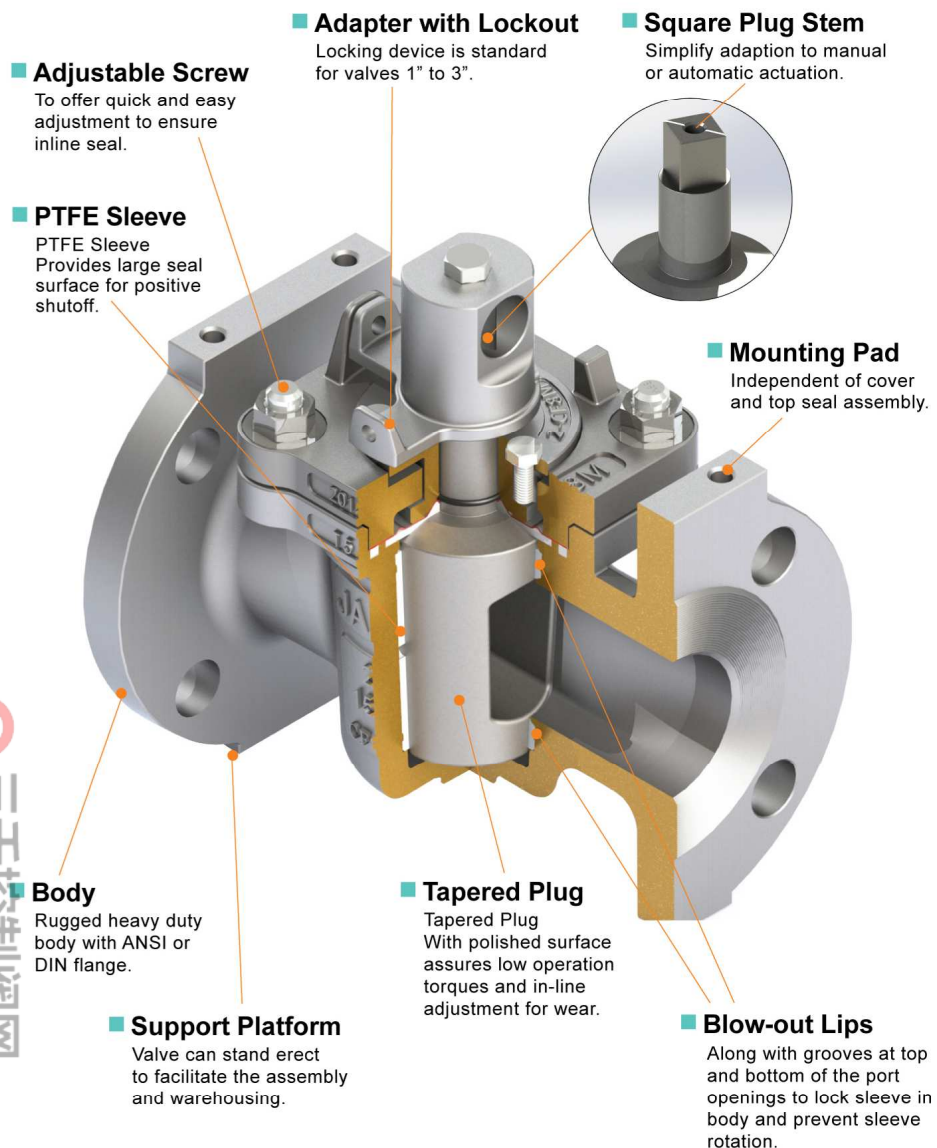

Sealing System and Fire Sealed

- Under normal conditions, there are three independent sealing systems to achieve seal integrity.
- **Primary seal** is provided by the plug/PTFE sleeve. The sleeve completely surrounds the plug and offers a large, circumferential sealing areas around the top and bottom of the plug and around the body ports. The sleeve is locked positively in the body to ensure leak tight shut-off.
 - **Secondary seal** is provided by the PTFE and metal diaphragms. PTFE diaphragm is tight closed to the plug stem, the metal diaphragm as a backup seal offers positive constant and uniform tightness to the PTFE diaphragm and wedge ring and also eliminates static electrical charge on the plug. The unique patented design of the formed metal diaphragm with a reserved space to prevent the leakage caused by physical deformation of any sealing parts.
 - **Tertiary seal** is PTFE wedge ring providing additional stem sealing and its independence is to fulfill the requirements of fire safe design. The o-ring of FKM material reinforces the function of preventing air leakage.

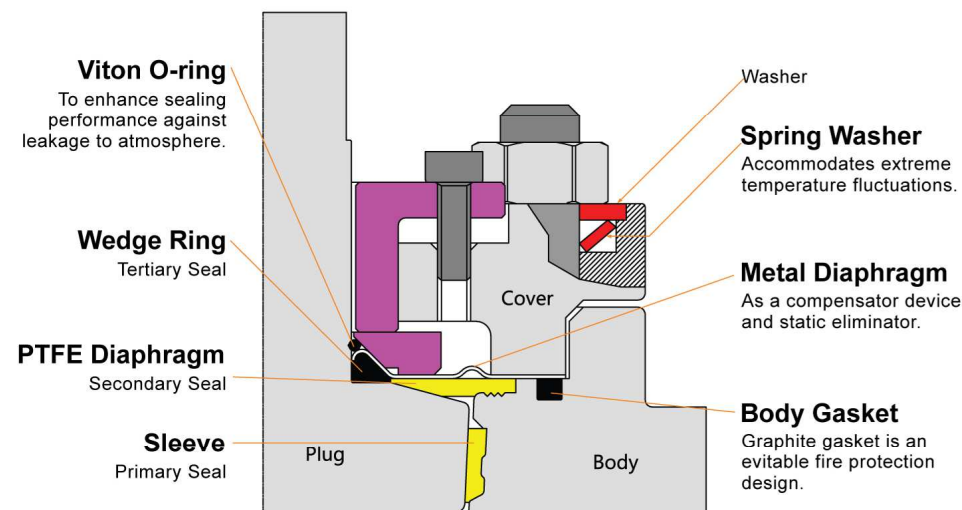

Triple Seal for extra protection at no extra cost.
Fire safe design is standard to provide effective shutoff in the event of a fire.

Fire Sealed

The JAKI sleeved plug valve is a fire-safe quarter-turn valve. The fire sealed valves incorporate Graphite wedge ring at the plug stem and Graphite gasket between body and cover. In normal operation, the PTFE sleeve and PTFE diaphragm act as the external sealing components; if these parts are destroyed by fire, fireproof wedge ring and body gasket maintain the seal to prevent external leakage.

After a fire, the adjustment screws might be loosed due to an extreme temperature fluctuation; the live-loaded spring washer provides a constant pressure on the cover and metal diaphragm.

Sleeved Plug Valve

Valve Parts and Materials

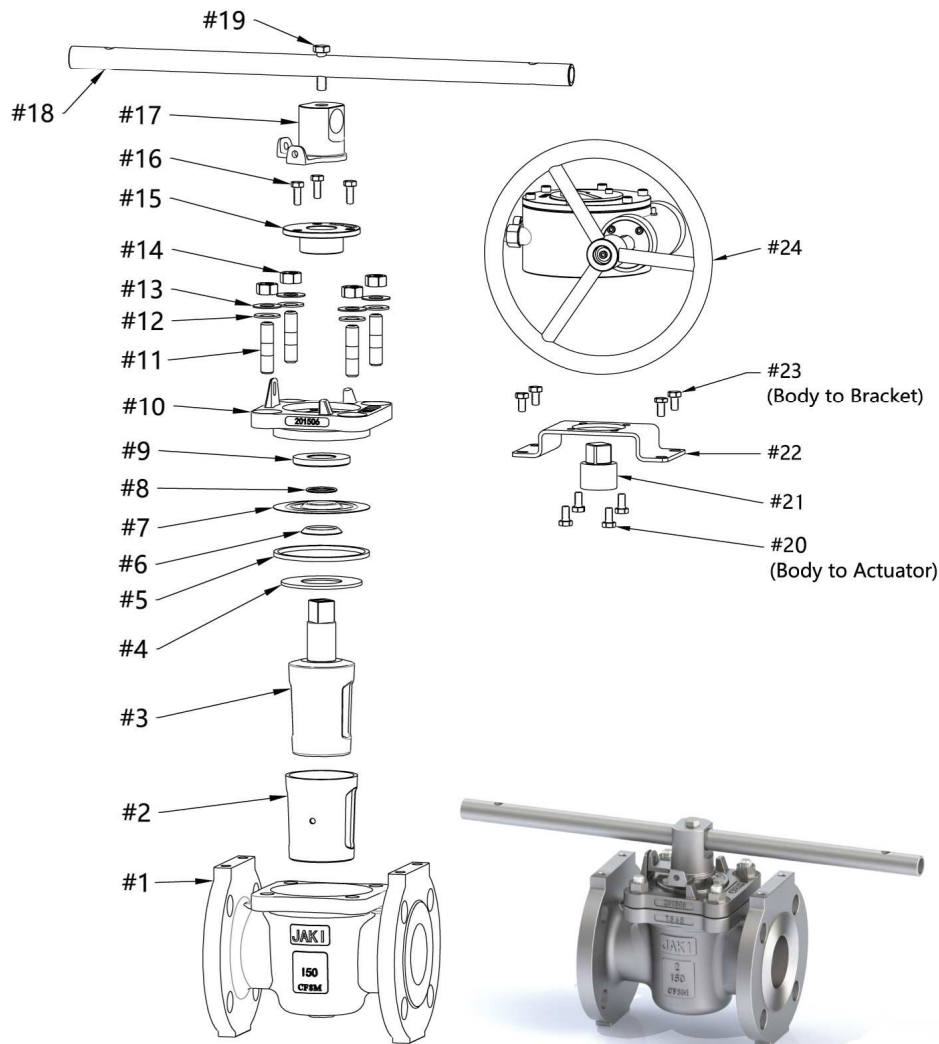

Material Specifications

Item	Description	Material	Qty.
1	Body	Carbon Steel, Stainless Steel	1
2	Sleeve	PTFE	1
3	Plug	Stainless Steel	1
4	Diaphragm	PTFE	1
5	Body Gasket	PTFE	1
6	PTFE Wedge Ring	PTFE	1
7	Metal Diaphragm	SS 316	1
8	O-ring	FKM	1
9	Trust Collar	SS 316	1
10	Cover	Carbon Steel / Stainless Steel	1
11	Cover Bolt	Stainless Steel	4
12	Spring Washer	SS 301	4
13	Washer	SS 304	4
14	Cover Nut	Stainless Steel	4
15	Gland	Carbon Steel / Stainless Steel	1
16	Adjustment Bolt	SS 304	3
Lever Operation			
17	Adapter	SS 304	1
18	Wrench	SS 304	1
19	Hex. Screw	SS 304	1
Gear Operation			
20	Hex. Screw	SS 304	4
21	Adapter	SS 304	1
22	Bracket	SS 304	1
23	Hex. Screw	SS 304	4
24	Worm Gear Box	Cast Iron	1

Body & Plug Materials:

- Carbon Steel
 - Stainless Steel
 - Hastelloy
 - Duplex 2205
 - Alloy 20
 - SMO 254
 - Monel
 - Inconel
- Other materials are available on request

Sleeve Materials

- PTFE
- 15% RTFE
- 25% RTFE
- TFM1600
- PFA
- UHMWPE
- Modified PTFE

Operator Available

- Bare Stem
- Wrench
- Gear
- Chain Wheel
- With Locking Device
- Actuator ***

*** Valves can be equipped with Electric / Pneumatic Actuators, and accessories like Limit Switch, Solenoid Valve, Filter Regulator, Positioner, etc.

Standard Specifications

Valve Design: API 599, API 6D
 Face to Face: ASME B16.10
 Flange: ASME B16.5
 Butt-weld: ASME B16.25
 Inspection & Testing: API 598, EN 12266-1

Product Range

Body Configurations: compact design, one piece body
 Valve Size: 2" ~ 12"
 Rating: Fig. P11F1 Class 150
 Fig. P11F2 Class 300

Test Pressure in bar (psi)

Pressure Rating	Class 150	Class 300
Shell by water	30 bar (435)	76 bar (1102)
Seat by water	22 bar (319)	56 bar (812)
Seat by air	6 bar(80)	

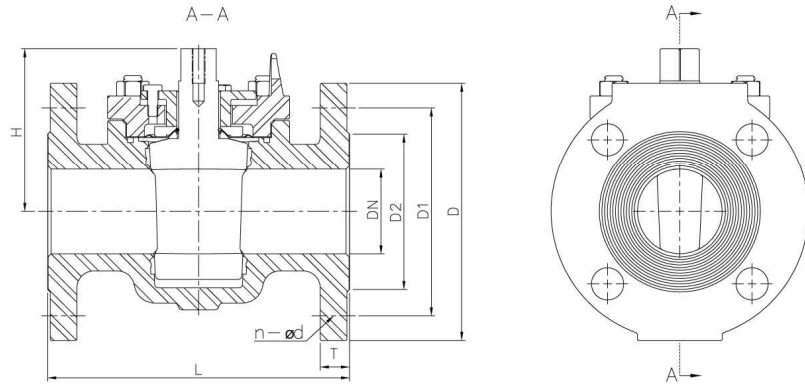

■ Dimensions

Flanged End / Class 150 / 2 way - Fig. P11F1 Sleeved Plug Valve

SIZE	L	D	D1	D2	T	n-Ød	H	WEIGHT
1"	127	108	79.5	51	12	4-15	87	4.7
1-1/2"	165	127	98.5	73	15	4-15	95	7.9
2"	178	152	120.5	92	16	4-19	97	11.6
2-1/2"	190	178	139.5	105	18	4-19	142	18.0
3"	203	190	152.5	127	19	4-19	156	18.9
4"	229	229	190.5	157	24	8-19	217	36.0
6"	267	279	241.5	216	26	8-22	242	71.0
8"	292	343	298.5	270	29	8-22	345	121.0
10"	330	406	362.0	324	31	12-25	393	205.0
12"	356	483	432.0	381	32	12-25	466	320.0

• Dimensions are in mm. Weight in kg

■ Dimensions

Flanged End / Class 300 / 2 way - Fig. P11F2 Sleeved Plug Valve

SIZE	L	D	D1	D2	T	n-Ød	H	WEIGHT
1"	165	124	89.0	51	18	4-19	105	5.3
1-1/2"	190	156	114.5	73	21	4-22	125	9.0
2"	216	165	127.0	92	23	8-19	140	13.7
2-1/2"	282	210	149.0	105	26	8-22	150	15.8
3"	282	210	168.5	127	29	8-22	185	25.2
4"	305	254	200.0	157	32	8-22	200	28.4
6"	403	318	270.0	216	37	12-22	460	68.3
8"	419	381	330.0	270	42	12-25	495	152.3
10"	457	445	387.5	324	48	16-29	560	267.8
12"	502	521	451.0	381	51	16-32	610	341.3

• Dimensions are in mm. Weight in kg

Manual Operators and Automation Accessories

Actuator Mounting Hole

SIZE	CLASS 150				
	A	TD	T	D	S
1"	113	45	M8	10	11
1-1/2"	148	45	M8	10	17
2"	159	57	M8	10	17
2-1/2"	181	89	M10	12	22
3"	181	89	M10	12	22
4"	202	102	M12	15	27
6"	238	102	M12	15	36
8"	260	152	M12	15	36
10"	297	152	M16	18	48
12"	321	152	M16	18	55

SIZE	CLASS 300				
	A	TD	T	D	S
1"	145	45	M8	10	11
1-1/2"	166	45	M8	10	17
2"	191	57	M8	10	17
2-1/2"	251	89	M10	12	22
3"	251	89	M10	12	22
4"	270	102	M12	15	27
6"	364	102	M12	15	36
8"	375	152	M12	15	36
10"	406	152	M16	18	48
12"	448	152	M16	18	55

MANUAL OPERATOR



ACTUATORS

PNEUMATIC

Hard Anodized Aluminum Housing
Rack and Pinion
 Double Acting
 Spring Return



ELECTRIC

Light weight, low consumption, large torque
The overheating protection device standard for extended service life.
 90° Rotary
 Modulating Series



ACCESSORIES

- Positioner: E/P and Smart type
- Limit Switch Box with indicator
- Solenoid Valve
- Air Filter Regulator
- Actuator Mounting Kits

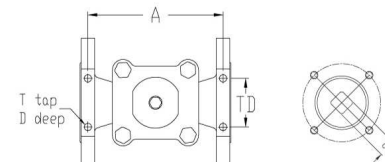

4 hole actuator mounting

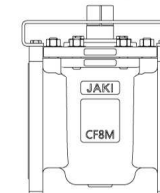

standard flange mount



Sleeved Plug Valve

Technical Data

Pressure Temperature Rating

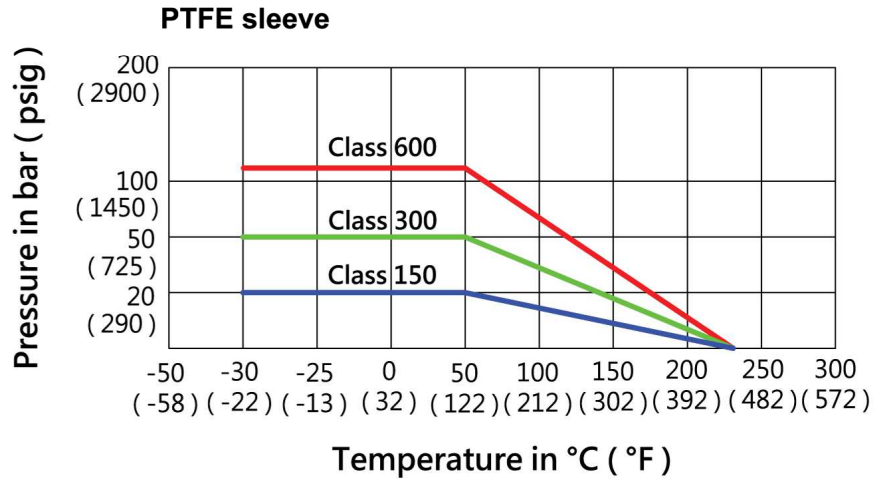

Pressure Temperature Rating

For 2 way valve

Valve Size	Inch DN	1	1-1/2	2	2-1/2	3	4	6	8	10	12
		25	40	50	65	80	100	150	200	250	300
Cv Values		49	104	198	276	327	615	1209	1580	2381	3569

Operating Torque

Class 150 & Class 300

Valve Size	Inch DN	1	1-1/2	2	2-1/2	3	4	6	8	10	12
		25	40	50	65	80	100	150	200	250	300
Break Torque		46	74	92	140	190	300	760	1360	2200	3300
Running Torque		23	37	46	70	95	150	380	680	1100	1650

- Above torque values are for valves with PTFE sleeve

Design Change

In order to follow the JAKI commitment to continuous improvement, we reserve the right to revise or modify product and performance without prior notice.