

卡套式软密封旋塞阀分解图
Sleeve type soft sealing plug valve

No cavities. No contamination. There are no body cavities where flow media can accumulate and contaminate future processing. This cavity-free design also prevents sticking.

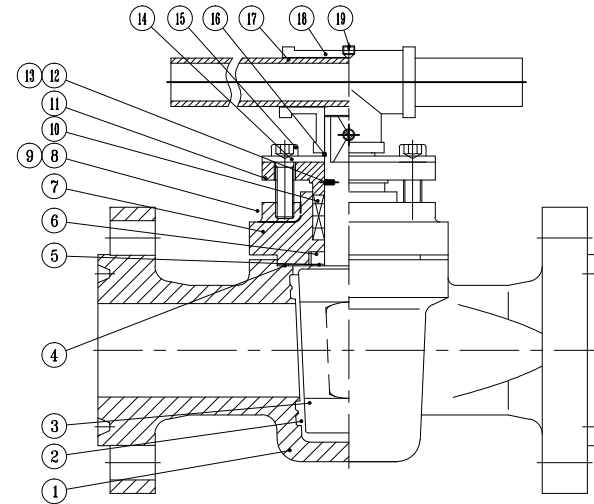

主要零部件材质 Material of main parts

序号 NO	名称 Part Name	材质 material
1	阀体 Body	A216 WCB, A351 CF8/CF8M/CF3/CF3M, 904L, CD4MCU, ...
2	卡套 Sleeve	PTFE, RPTFE, PPL, ...
3	旋塞 Plug	A216 WCB, A351 CF8/CF8M/CF3/CF3M, 904L, CD4MCU, ...
4	垫片 Gasket	PTFE, RPTFE, PPL, ...
5	垫片 Gasket	PTFE, RPTFE, PPL, ...
6	调节垫 Adjust the pad	SS304/SS316
7	阀盖 Bonnet	A216 WCB, A351 CF8/CF8M/CF3/CF3M, 904L, CD4MCU, ...
8	螺栓 Bolt	A193 B7/B8/B8M
9	螺母 Nut	A194 2H/8/8M
10	填料 Packing	Flexible graphite/PTFE
11	填料压板 Gland	A216 WCB, A351 CF8/CF8M/CF3/CF3M, 904L, CD4MCU, ...
12	弹簧 Spring	SS304
13	球 Ball	SS304
14	定位片 Locating piece	SS304/CS+Zn
15	内六角螺钉 Hex screw	A193 B7/B8/B8M
16	卡簧 circlip	SS304/
17	手柄 handle	CS+Zn
18	手柄套 handle set	CS+Zn
19	紧定螺钉 Set screw	CS+Zn

产品结构特点 Product structure features

卡套式锥形旋塞阀是采用具有自润滑作用的PTFE衬套镶嵌在阀体内，而且是在压力下将衬套压入，这样就能防止在衬套与阀体间产生

泄漏。卡套式锥形旋塞阀在使用中无须注入可能导致污染的密封脂，双向流动，采用较低的转矩，独特的360°金属唇边保护和固定卡套，使密封部位没有金属对金属的直接接触，估卡套式锥形旋塞阀密封性能良好，并可避免密封面要是现象。其适用范围广，摩擦因数小，使用寿命长，并且是非金属-金属密封，对旋塞加工要求可以降低，因而对与中小口径的旋塞阀较普遍的采用衬套结构形式。

Bayonet type tapered plug valves are self lubricated PTFE bushing embedded in the body and are pressurized to prevent leakage between the bushing and the body. Taper plug valves in use of cutting sleeve type has no sealing grease injection may cause pollution, two-way flow, adopting low torque, unique 360° metal lip protection and fixed card sets, make direct contact with no metal to metal seal parts, for taper plug valves of cutting sleeve type has the good seal performance, and can be avoided if sealing surface phenomenon. Its applicable scope is wide, the friction factor is small, the service life is long, and is the non-metal - metal seal, may reduce to the plug processing request, therefore to the small and medium caliber plug valve more generally USES the bush structure form.

其主要结构特点 main structural features

1、阀体进出口端窗口设计为双道沟槽密封环结构，旋塞在旋转过程中，其密封副间的密封比压在逐渐变化，直至到达全开或全关位置时，产生足够的密封比压，密封副到达零泄漏。

2、双道沟槽密封环既可以使PTFE衬套稳固在阀体内不产生位移，又可以吸收由于温差变化引起衬套产生的微量变形，同时衬套与旋塞之间产生有力的擦拭作用，又提高了密封面的使用寿命。

3、PTFE衬套内，根据使用温度和工作介质采用不同材料的填充物，润滑好、寿命长。

4、阀门的密封性是通过卡套四周的密封面来实现的。独特的360°金属唇边保护固定卡套。

5、阀门没有空腔，介质不易积聚。

6、金属唇边在旋塞旋转时提供自洁的作用，适用于粘稠和易结垢的工况。

7、双向流动，使用安装更方便。

8、零件材质及端部连接尺寸可根据实际工况或用户要求合理选配，满足各种工程需求。

1, the valve body inlet and outlet end window is designed as a double-channel groove seal ring structure, the plug in the process of rotation, the sealing pressure between the sealing pair in the gradual change, until the full open or closed position, produce enough seal pressure, sealing pair to zero leakage.

2, double channel groove sealing ring can not only make PTFE bushing stable in the valve body does not produce displacement, but also can absorb the microdeformation caused by the change of temperature bushing, at the same time between the bushing and the cock has a strong wiping effect, and improve the service life of the sealing surface.

3, PTFE bushing, according to the use of temperature and working medium using different materials of filler, good lubrication, long life.

4, the sealing of the valve is through the sealing surface around the jacket. Unique 360° metal lip protection fixed card sets.

5, the valve has no cavity, the medium is not easy to accumulate.

6, The metal lip can provide self-cleaning function when the cock rotates, which is suitable for viscous and easy scaling conditions.

7, two-way flow, more convenient to use and install.

8, Material and end connection dimensions of parts can be reasonably selected and matched according to actual working conditions or user requirements to meet various engineering requirements.

技术规范 The technical specification

结构形式 Structure form	BC
驱动方式 Drive a mode	手动、电动、气动 Manual, electric, pneumatic
设计标准 Design criteria	API6D/API599/BS5353/GB/T22130
结构长度标准 Structural length standard	API6D/ASME B16.10/EN558
法兰连接标准 Flange connection standard	ASME B16.5/EN1092/HG/T20592
对焊连接标准 Welding connection standard	ASME B16.25/B36.10
NPT连接标准 NPT connection standard	ASME B1.20.1
压力温度额定值 Pressure temperature rating	ASME B16.34
检验标准 Inspection standard	API6D/API598
防火标准 Fire protection standard	API607

产品性能规范 Product performance specification

公称压力 (LB) Nominal pressure	壳体实验压力 (Mpa) Shell test pressure	密封试验压力 (Mpa) Seal test pressure	适用温度 (°C) Suitable temperature	适用介质 Applicable medium
150	3.0	2.2	≤180°C	水、蒸气、油品 Water, steam, oil
300	7.5	5.5		
600	15.0	11.0		
900	22.5	16.5		

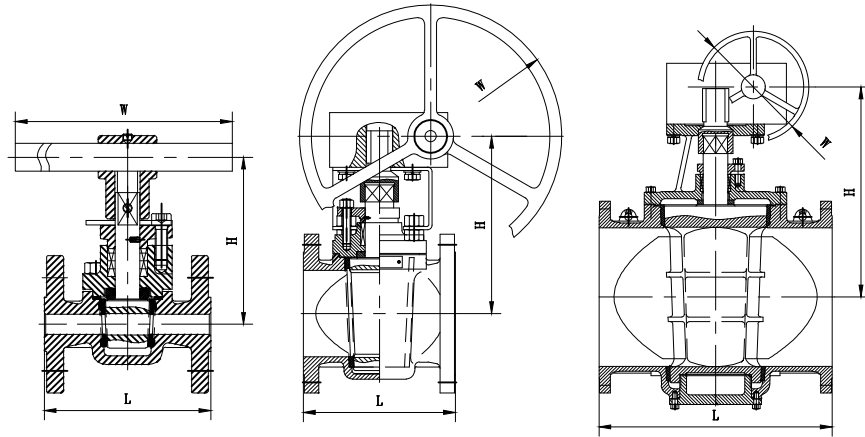

型号 (Model)	X 43F-150LB																	
压力等级 (Pressure)	150LB																	
口径 (Size)	DN	15	20	25	40	50	80	100	150	200	250	300	350	400	450	500	600	
	in	1/2	3/4	1	1 1/2	2	3	4	6	8	10	12	14	16	18	20	24	
短型 (Short type)	L-RF	108	118	127	165	178	203	229	267	292	330	356	/					
	L-BW	152	178	203	229	267	330	356	457	521	559	635						
	L-RTJ								191	216	241	279						
常规型 (regular type)	L-RF	/							394	457	533	610	/					
	L-BW																	
	L-RTJ								406	470	546	622						
文丘里型 (Venturi type)	L-RF	/							533	610	686	762	864	914	1067	/		
	L-BW								599	635	686	762	864	914	1067			
	L-RTJ								546	622	699	775	876	927	1080			
全通径 (full bore)	L-RF					267	343	432	546	622	660	762	/					
	L-BW																	
	L-RTJ					279	356	445	559	635	673	775						
H	71	79	88	109	120	145	215	285	350	365	480	540	625	735	/			895
W	300	300	400	400	500	600	800	460	600	600	600	600	600	600				600

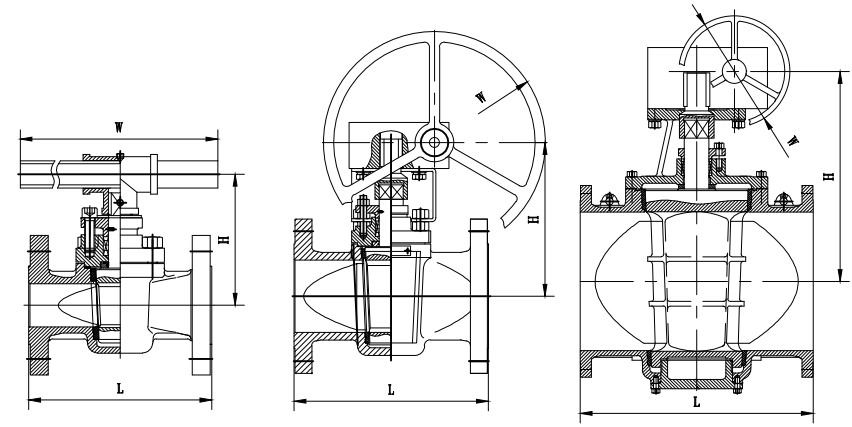

型号 (Model)	X 43F-300LB																		
压力等级 (Pressure)	300LB																		
口径 (Size)	DN	15	20	25	40	50	80	100	150	200	250	300	350	400	450	500	600		
	in	1/2	3/4	1	1 1/2	2	3	4	6	8	10	12	14	16	18	20	24		
短型 (Short type)	L-RF	140	152	165	190	216	283	305	403	419	457	502	/						
	L-BW	152	178	203	229	267	330	356	457	521	559	635							
	L-RTJ								232	298	321	419							435
常规型 (regular type)	L-RF	/							403	502	568	/			914	991	1143		
	L-BW																		
	L-RTJ								419	518	584				930	1010	1165		
文丘里型 (Venturi type)	L-RF	/							403	419	457	502	762	838	914	991	1143	/	
	L-BW								457	521	559	635	762	838	914	991	1143		
	L-RTJ								419	435	473	518	778	854	930	1010	1165		
全通径 (full bore)	L-RF					283	387	457	559	686	826	965	/						
	L-BW																		
	L-RTJ					298	403	473	575	702	841	981							
H	71	79	88	109	120	145	215	285	350	365	480	540	625	735	/			895	
W	300	300	400	400	500	600	800	460	600	600	600	600	600	600				600	600

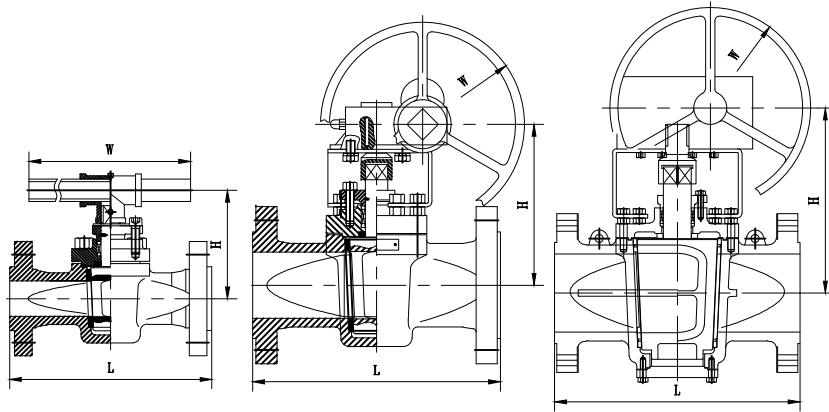

型号 (Model)		X 43F-600LB																
压力等级 (Pressure)		600LB																
口径 (Size)	DN	15	20	25	40	50	80	100	150	200	250	300	350	400	450	500	600	
	in	1/2	3/4	1	1 1/2	2	3	4	6	8	10	12	14	16	18	20	24	
常规型 (regular type)	L-RF	165	190	216	229	292	356	432	559	660	787							
	L-BW	165	190	216	229	292	356	432	559	660	787							
	L-RTJ						295	359	435	562	664							791
	L-RTJ						295	359	435	562	664							791
文丘里型 (Venturi type)	L-RF								559	660	787	838	889	991	1092	1194	1295	
	L-BW								559	660	787	838	889	991	1092	1194	1295	
	L-RTJ								562	664	791	841	892	994	1095	1200	1305	
全通径 (full bore)	L-RF					330	445	508	660	794	940	1067						
	L-BW							559	711	845	1016	1067						
	L-RTJ					333	448	511	664	797	943	1070						
H		95	105	125	135	160	185	285	385	405	10	545	595	625	680	800	865	
W		300	400	400	450	600	800	460	460	600	600	600	600	600	600	600	600	

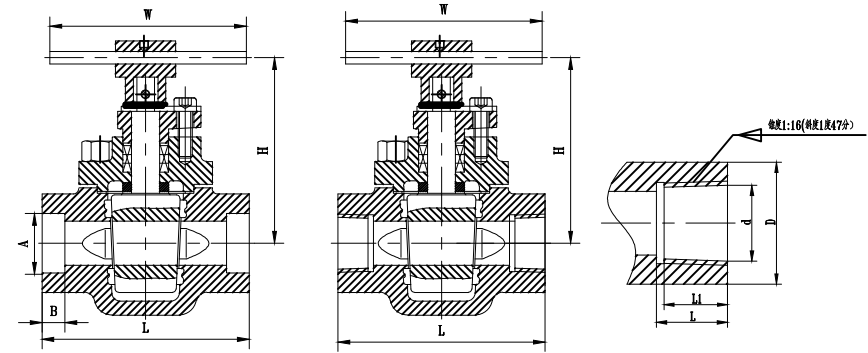

型号 (Model)		X 1(6)3F-(150-800LB)				
压力等级 (Pressure)		150-800LB				
口径 (Size)	DN	15	20	25	40	50
	in	1/2	3/4	1	1 1/2	2
L	SW	82	118	118	140	165
	NPT	82	118	118	140	165
	BW	82	118	118	140	165
SW	A	21.7	27.1	33.8	48.6	61.1
	B	9.6	12.7	12.7	12.7	15.8
NPT	d	18.48	23.67	29.87	44.7	56.74
	L	17	17	20	23	23
	L1	14	14	17	20	20
	模数 (pitch)	1.814	1.814	2.209	2.209	2.209
	每英寸牙数 (Number of teeth per inch)	14	14	11.5	11.5	11.5
H		100	100	105	125	145
W		400	400	500	600	800

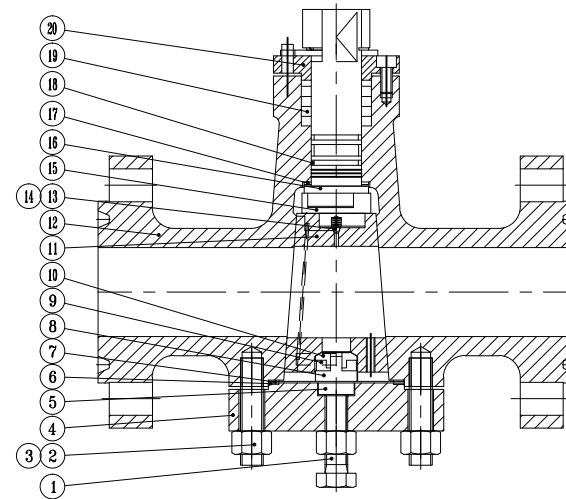
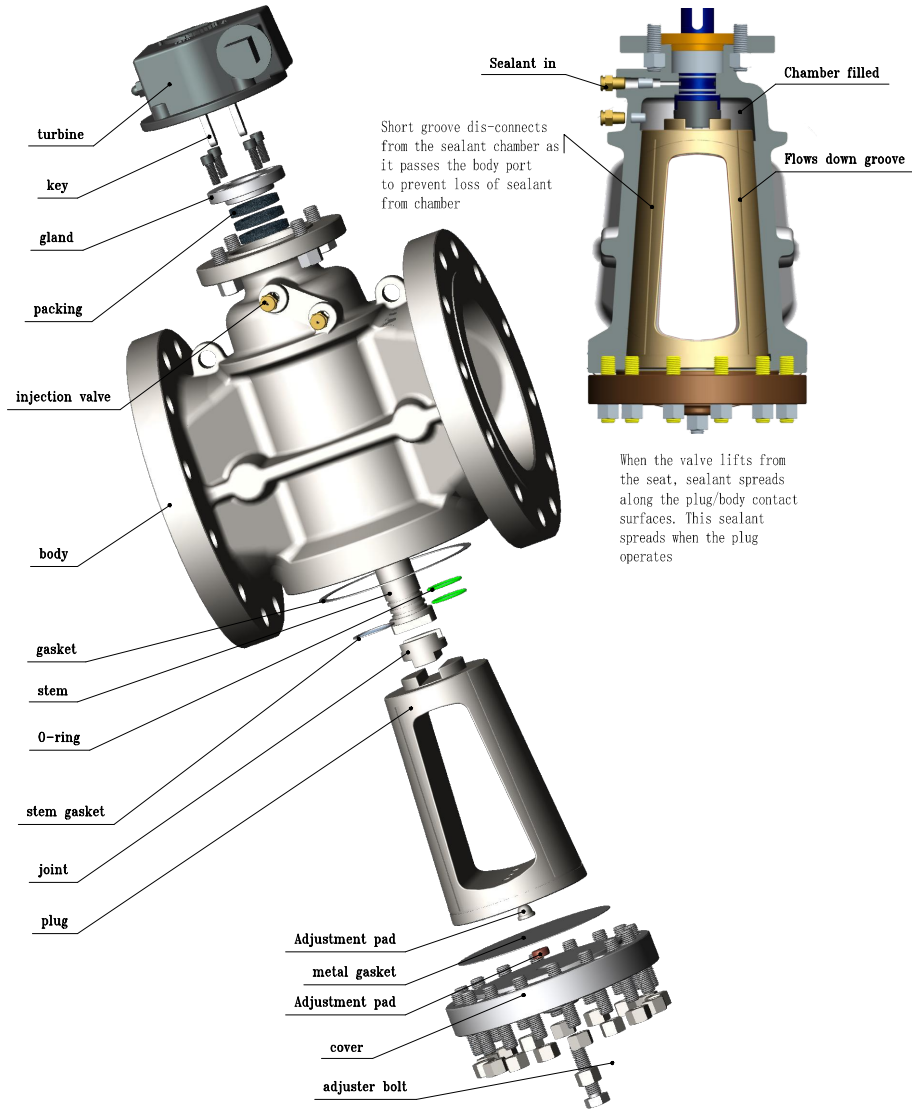

主要零部件材质 Material of main parts

序号 NO	名称 Part Name	材质 material
1	调节螺钉 Adjust the screw	A193 B7/B8/B8M
2	螺栓 Bolt	A193 B7/B8/B8M
3	螺母 Nut	A194 2H/8/8M
4	阀盖 Bonnet	A216 WCB/A351 CF8/CF8M/
5	垫块 block	SS410
6	复合垫片 Composite gasket	SS304+Graphite
7	金属膜片 Metal diaphragm	SS304
8	碟簧座 Disc spring seat	SS410
9	碟簧 Disc spring	65Mn
10	调节垫 Adjust the pad	SS410
11	旋塞 Plug	A216 WCB/A351 CF8/CF8M
12	阀体 Body	A216 WCB/A351 CF8/CF8M/
13	球 Ball	SS304
14	弹簧 Spring	SS304
15	结合子 Combined with the child	A216 WCB
16	阀杆 Stem	SS410/SS4140
17	阀杆垫片 Stem gasket	PTFE
18	O型圈 o-rings	Viton
19	填料 Packing	Graphite
20	填料压盖 Gland	A216 WCB/A351 CF8/CF8M/

产品结构特点 Product structure features

压力平衡式倒锥形旋塞阀是可以用于任何工况的理想切断阀,包括大多数恶劣操作环境下也能使用。可用于动作要求快、无故障和高效密封要求的场合,设计非常紧凑,要求的安装空间较小,可以在任意位置安装。该类阀的基本操作相当简便,当旋塞转动90°时,阀门就从开到关的位置:反之亦然。

Pressure-balanced inverted conical plug valves are ideal for any operating condition, including most severe operating conditions. Can be used for fast action, trouble-free and efficient sealing requirements, the design is very compact, the required installation space is small, can be installed in any location. Basic operation of the valve is quite simple, when the cock rotate 90°, the location of the valve from on to off, or vice versa.

工作原理 operating principle

其工作过程是通过阀杆旋转90°使旋塞上的通道口与阀体上的通道口接通或断开,实现阀门开启或关闭。通过该阀腔上部设计的注脂阀注入密封脂,该密封脂在注入压力作用下通过旋塞表面的特殊油槽均匀地涂在密封面上,形成致密的油膜层,实现阀门双向密封并起到润滑密封面的作用。在旋塞大端开有流通的小孔,使管道介质能进入旋塞底部,旋塞在底部介质推动下向上紧贴旋塞倒锥面。旋塞小端装有单向阀,当阀腔上部的油脂压力低于介质压力时管道介质通过单向阀进入阀体上腔以补充油脂压力。同时旋塞在上腔油脂压力及旋塞自重作用下与旋塞底部向上的介质推力保持平衡,可以大大减轻密封面的密封比压,降低阀门操作力矩,延长阀门使用寿命。

旋塞表面硬化处理并开有特殊油槽回路,阀门外有两个密封脂注入装置,一个是通过注入密封脂对阀门实现紧急密封,另一个是将密封脂注入阀体上腔。锥形旋塞体的小端通过平衡环与阀杆连接,阀体底部阀盖上装有调节支撑,可以调整旋塞的位置,阀门采用防火设计,有静电导出装置,过流道按照API6D的规定有全通径、缩径。

Its working process is through the valve stem rotate 90° made the gangway on the cock and body connected or disconnected, spilling the valve opened or closed. The sealing grease is injected through the fat-injection valve designed on the upper part of the valve chamber. Under the action of the injection pressure, the sealing grease is evenly coated on the sealing surface through the special oil groove on the surface of the cock, forming a dense oil film layer, realizing the two-way sealing of the valve and playing the role of lubricating sealing surface. The large end of the cock is provided with a small hole for circulation, so that the pipe medium can enter the bottom of the cock. The small end of the cock is equipped with a one-way valve. When the grease pressure on the upper part of the valve chamber is lower than the medium pressure, the pipe medium enters the upper chamber of the valve body through the one-way valve to supplement the grease pressure. At the same time in the upper chamber oil pressure and the role of the plug self weight and the bottom of the plug upward medium thrust balance, can greatly reduce the sealing pressure on the sealing surface, reduce the operating torque of the valve, extend the service life of the valve.

The surface of the cock is hardened and special oil groove circuit is opened. There are two sealing grease injection devices outside the valve, one is to achieve emergency sealing of the valve by injecting sealing grease, the other is to inject sealing grease into the upper chamber of the valve body. The small end of the conical cock body is connected to the stem through the balance ring. The valve body bottom cover is equipped with adjusting support to adjust the position of the cock.

其主要结构特点 main structural features

1. 阀体。采用倒装式结构,整体铸造,强度高,刚性好,受力均匀,阀门重心与管道中心基本重合,操作稳定性好。阀体密封锥面采用高速精密加工,经研磨后表面粗糙度精度高于Ra0.8。

1. The valve body. Adopt flip-type structure, integral casting, high strength, good rigidity, uniform force, valve center of gravity and pipeline center basically coincide, good operation stability. The valve body seal cone is processed by high-speed fine grinding, and the surface roughness precision after grinding is higher than Ra0.8.

2. 旋塞。采用倒装式旋塞,整体锻造,精密机械加工并研磨后表面粗糙度可达Ra0.4。旋塞表面采用氮化、镀镍磷合金或者喷涂硬质合金等表面处理手段提高表面硬度,超音速喷涂硬质合金的表面硬度可达到65HRC以上,镀镍磷并经热处理后,其表面硬度可达58~60HRC。在油膜润滑下具有超强的耐磨性能。旋塞锥体的上部有一止回阀,可补偿阀腔上部的注油压力。旋塞的下部指油平衡孔,可将介质压力引入旋塞底部,使旋塞压紧阀体,起到密封作用。

3. 密封副。采用金属密封结构加注油脂密封,由于密封油脂的填充占位作用,介质中的固体颗粒不会进入密封面,对密封面有非常好的保护作用。因为油脂的润滑,使得阀门操作力矩小,操作省力。

特殊的非对称油槽设计,转动旋塞时密封脂自动加注无泄漏,完全保证油膜完整,密封可靠。这种非对称的油槽设计油耗损失非常小,延长了油脂的加注时间和使用周期。锥面密封,密封接触面积大。油膜润滑,使用寿命长。

4. 阀杆及阀杆密封。阀杆的强度和密封性能是影响阀杆操作及阀门整体性能的主要因素之一。阀杆的受力主要来自于填料处的摩擦力、操作力矩及介质的推力。阀杆与旋塞采用滑环式连接方式,可减少阀杆中心与旋塞锥面的同心度误差,改善阀杆的受力条件和操作性能。阀杆采用防飞出设计,可在线更换填料密封件。阀杆密封采用防火填料、O型密封圈、加注密封脂三重密封设计。阀杆机加工后表面粗糙度可到Ra0.4,完全满足阀杆密封要求,可长期可靠工作,免紧固维修。阀杆整体锻造,并加调质处理,强度高韧性好。阀杆表面采用氮化或镀镍磷合金,表面硬度高,抗摩擦磨损。

5. 阀盖及底部结构。底部阀盖是阀门底部承压部件,同时又是底部密封垫片、底部调节杆的固定和安装支撑件,要求具有高的刚度和强度。底部阀盖的密封采用整体密封垫完全隔离式结构,在保证阀盖螺栓紧固时阀门具有绝对可靠的密封。安装在阀盖底部的调节杆采用内置式结构,调整完成后旋紧压盖完全零泄漏。底部调节杆支持旋塞,导出旋塞因各种原因产生的静电。

2. Cock. Using inversion plug, the overall forging, precision machining and grinding surface roughness can reach Ra0.4. After the surfaces of the cock, plating nickel phosphorus alloy nitride or spraying hard alloy surface treatment to improve the surface hardness, such as supersonic spraying hard alloy surface hardness can reach above 65 HRC, nickel-plated phosphor and after heat treatment, the surface hardness of 58 ~ 60 HRC. Under the oil film lubrication with super wear resistance. The upper part of the tap cone is provided with a check valve to compensate the oil pressure in the upper part of the valve chamber. The lower part of the tap oil balance hole, can be introduced into the media pressure at the bottom of the cock, so that the plug pressure valve body, play a sealing role.

3. Sealing pair. The metal sealing structure is used for grease sealing. Due to the filling effect of the sealing grease, the solid particles in the medium will not enter the sealing surface, which has a very good protective effect on the sealing surface. Because of grease lubrication, so that the valve operating torque is small, easy to operate. Special asymmetric oil groove design, automatic filling of sealing grease without leakage when rotating the cock, completely ensuring the integrity of oil film and reliable sealing. The asymmetrical tank design results in very low fuel loss and prolongs the filling time and service life of the grease. Cone seal, sealing contact area is large. Oil film lubrication, long service life.

4. Stem and stem seal. Stem strength and sealing performance is one of the main factors affecting stem operation and overall valve performance. Stem force is mainly from the friction at the packing, operating torque and medium thrust. The connecting mode of valve stem and cock is slip-ring type, which can reduce the concentricity error between the center of valve stem and the cone surface of cock, and improve the stress condition and operation performance of valve stem. The stem is designed to fly out and the packing seal can be replaced online. Stem seal with fireproof packing, O-ring seal, grease triple seal design. After machining, the surface roughness of the stem can reach Ra0.4, which fully meets the sealing requirements of the stem and can work reliably for a long time without fastening and maintenance. Valve stem integral forging, and add conditioning treatment, high strength and good toughness. The surface of valve stem is nitrided or nickel-phosphor plated with high surface hardness and friction resistance.

5. Bonnet and bottom construction. The bottom bonnet is the bearing part at the bottom of the valve, as well as the fixed and installed support for the bottom sealing gasket and bottom regulating rod, requiring high stiffness and strength. The bottom cover is sealed with a fully isolated integral gasket to ensure an absolutely reliable seal when the cover bolts are tightened. The regulating rod installed at the bottom of the bonnet is of built-in construction, and the gland is screwed with zero leakage after adjustment. The bottom adjusting rod supports the cock and leads to the static electricity generated by the cock for various reasons.

技术规范 The technical specification

结构形式 Structure form	BC
驱动方式 Drive a mode	手动、电动、气动 Manual, electric, pneumatic
设计标准 Design criteria	API6D/API599/BS5353/GB/T22130
结构长度标准 Structural length standard	API6D/ASME B16.10/EN558
法兰连接标准 Flange connection standard	ASME B16.5/EN1092/HG/T20592
对焊连接标准 Welding connection standard	ASME B16.25/B36.10
NPT连接标准 NPT connection standard	ASME B1.20.1
压力温度额定值 Pressure temperature rating	ASME B16.34
检验标准 Inspection standard	API6D/API598
防火标准 Fire protection standard	API607

产品性能规范 Product performance specification

公称压力 (LB) Nominal pressure	壳体实验压力 (Mpa) Shell test pressure	密封试验压力 (Mpa) Seal test pressure	适用温度 (°C) Suitable temperature	适用介质 Applicable medium
150	3.0	2.2	≤180°C	水、蒸气、油品 Water, steam, oil
300	7.5	5.5		
600	15.0	11.0		
900	22.5	16.5		

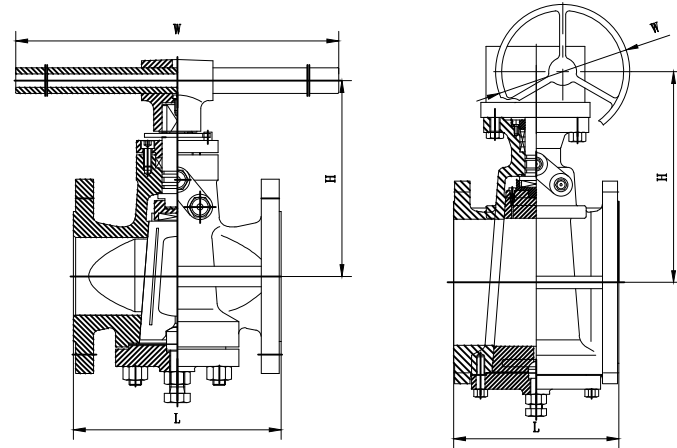

型号 (Model)		X 47W-150LB(短型)				
压力等级 (Pressure)		150LB				
NPS	DN	L			H	W
		RF	BW	RTJ		
1.5	40	165	165	178	133	300
2	50	178	267	191	190	400
2.5	65	191	305	203	198	500
3	80	203	330	216	210	600
4	100	229	356	241	263	600
6	150	267	457	279	285	360
8	200	292	521	305	368	460
10	250	330	559	343	408	600
12	300	356	635	368	460	600

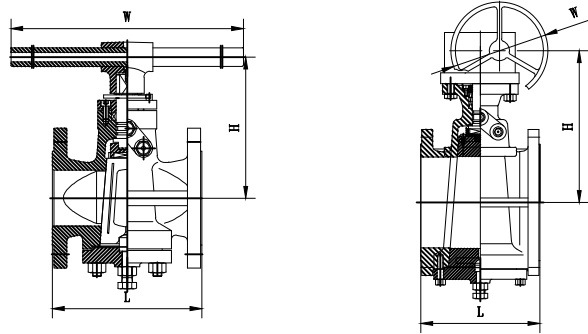

型号 (Model)		X 47W-150LB(常规型)				
压力等级 (Pressure)		150LB				
NPS	DN	L			H	W
		RF	BW	RTJ		
6	150	394	/	406	285	360
8	200	457		470	368	460
10	250	533		546	408	600
12	300	610		622	460	600

型号 (Model)		X 47W-150LB(文丘里型)				
压力等级 (Pressure)		150LB				
NPS	DN	L			H	W
		RF	BW	RTJ		
10	250	533	559	546	408	600
12	300	610	635	622	460	600
14	350	686	686	699	540	600
16	400	762	762	775	590	600
18	450	864	864	876	615	600
20	500	914	914	927	705	600
24	600	1067	1067	1080	755	600

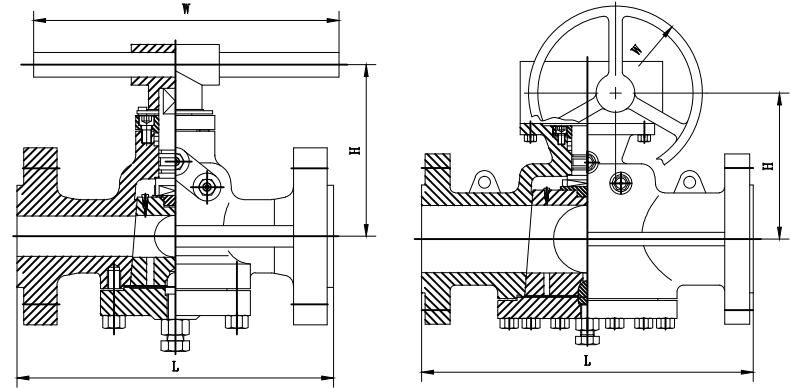

型号 (Model)		X 47W-150LB(圆形全通径)				
压力等级 (Pressure)		150LB				
NPS	DN	L			H	W
		RF	BW	RTJ		
2	50	267	/	279	190	400
2.5	65	298		311	195	500
3	80	343		356	210	600
4	100	432		445	263	600
6	150	546		559	285	360
8	200	622		635	368	460
10	250	660		673	408	600
12	300	762		775	460	600

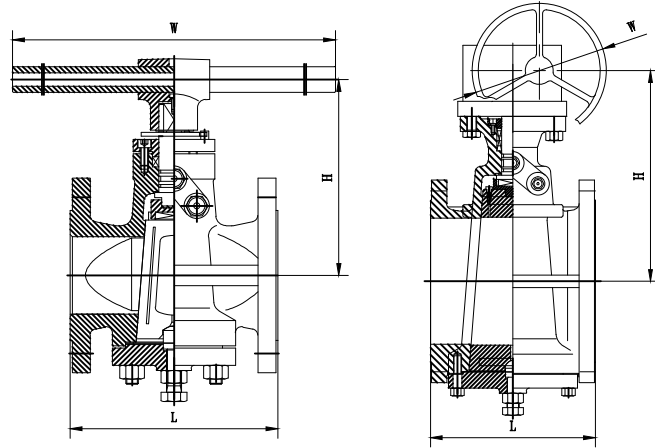

型号 (Model)		X 47W-300LB(短型)				
压力等级 (Pressure)		300LB				
NPS	DN	L			H	W
		RF	BW	RTJ		
1.5	40	190	190	203	133	300
2	50	216	267	232	190	400
2.5	65	241	305	257	195	500
3	80	283	330	289	210	600
4	100	305	356	321	263	600
6	150	403	457	419	285	360
8	200	419	521	435	368	460
10	250	457	559	473	408	600
12	300	502	635	518	460	600

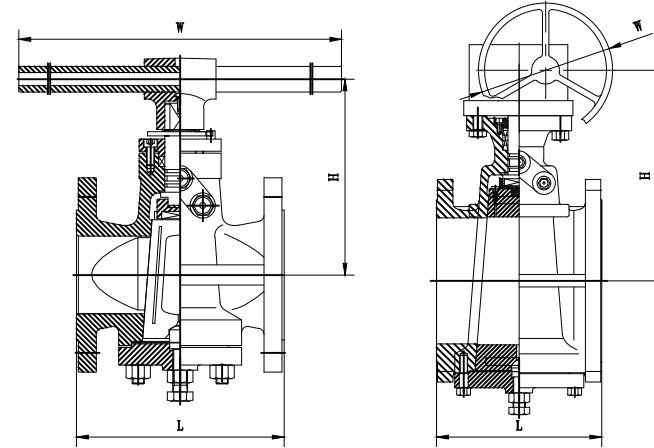

型号 (Model)		X 47W-300LB(常规型)				
压力等级 (Pressure)		300LB				
NPS	DN	L			H	W
		RF	BW	RTJ		
6	150	403	/	419	285	360
8	200	502		518	368	460
10	250	568		584	408	600
12	450					
14	500					
16	600					
18	450	914		930	615	600
20	500	991		1010	705	600
24	600	1143		1165	755	600

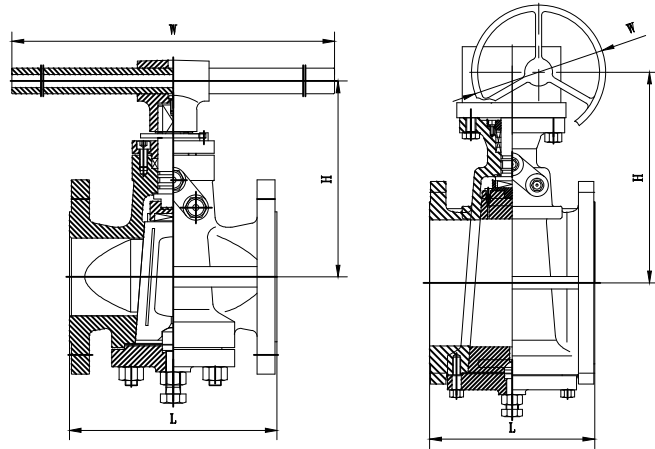

型号 (Model)		X 47W-300LB(文丘里型)				
压力等级 (Pressure)		300LB				
NPS	DN	L			H	W
		RF	BW	RTJ		
6	150	403	457	419	285	360
8	200	419	521	435	368	460
10	250	457	559	473	408	600
12	300	502	635	518	460	600
14	350	762	762	778	540	600
16	400	838	838	854	590	600
18	450	914	914	930	615	600
20	500	991	991	1010	705	600
24	600	1143	1143	1165	755	600

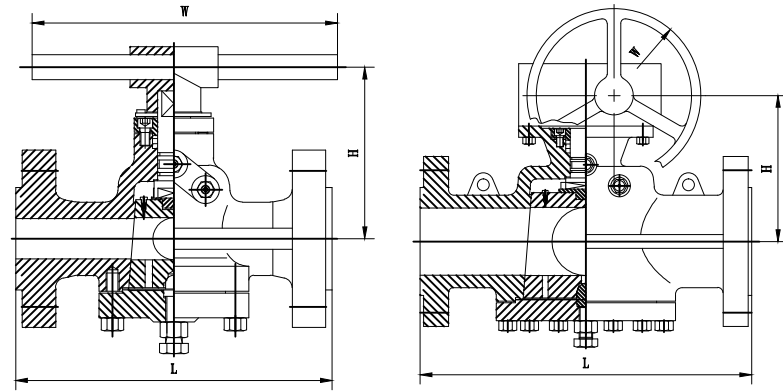

型号 (Model)		X 47W-300LB(圆形全通径)				
压力等级 (Pressure)		300LB				
NPS	DN	L			H	W
		RF	BW	RTJ		
2	50	283	283	298	183	400
2.5	65	330	330	346	195	500
3	80	387	387	403	210	600
4	100	457	457	473	263	600
6	150	559	559	575	285	360
8	200	686	686	702	368	460
10	250	826	826	841	408	600
12	300	965	965	981	460	600

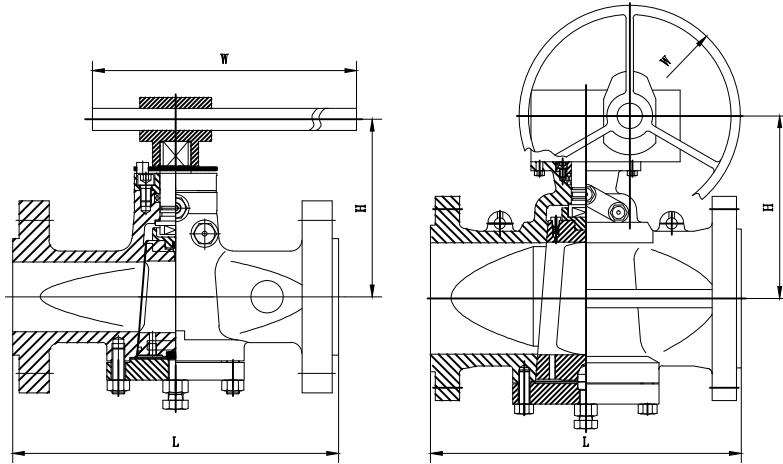

型号 (Model)		X 47W-600LB(常规型)				
压力等级 (Pressure)		600LB				
NPS	DN	L			H	W
		RF	BW	RTJ		
2	50	292	292	295	183	400
2.5	65	330	330	333	195	500
3	80	356	356	359	210	600
4	100	432	432	435	263	360
6	150	559	559	562	285	360
8	200	660	660	664	368	460
10	250	787	787	791	408	600

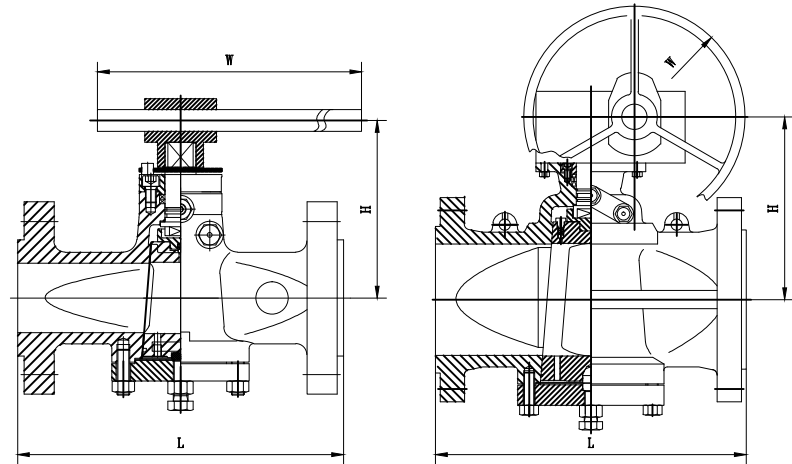

型号 (Model)		X 47W-600LB(文丘里型)				
压力等级 (Pressure)		600LB				
NPS	DN	L			H	W
		RF	BW	RTJ		
6	150	559	559	562	285	360
8	200	660	660	664	368	460
10	250	787	787	791	408	600
12	300	838	838	841	460	600
14	350	889	889	892	540	600
16	400	991	991	994	590	600
18	450	1092	1092	1095	615	600
20	500	1194	1194	1200	705	600
24	600	1397	1397	1407	755	600

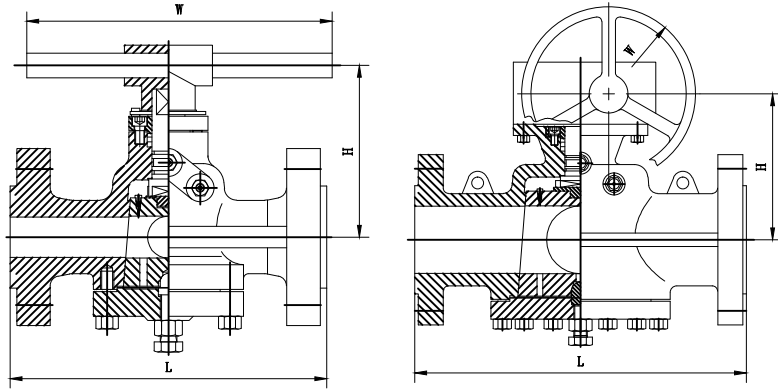

型号 (Model)		X 47W-600LB(圆形全通径)				
压力等级 (Pressure)		600LB				
NPS	DN	L			H	W
		RF	BW	RTJ		
2	50	330		333	183	400
2.5	65	381		384	195	500
3	80	445		448	210	600
4	100	508	559	511	263	600
6	150	660	711	664	285	360
8	200	794	845	797	368	460
10	250	940	1016	943	408	600
12	300	1067	1067	1070	460	600

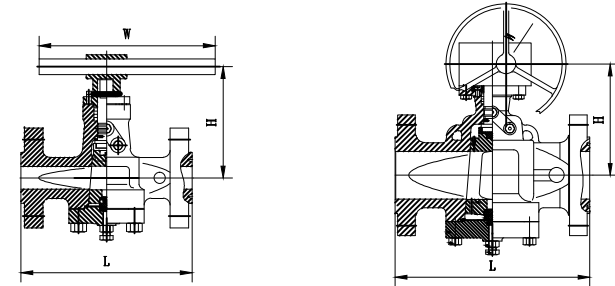

型号 (Model)		X 47W-900LB(常规型)				
压力等级 (Pressure)		900LB				
NPS	DN	L			H	W
		RF	BW	RTJ		
2	50	368		371	213	400
2.5	65	419		422	220	500
3	80	381	381	384	232	600
4	100	457	457	460	275	600
6	150	610	610	613	345	360
8	200	737	737	740	426	460
10	250	838	838	841	495	600

型号 (Model)		X 47W-900LB(文丘里型)				
压力等级 (Pressure)		900LB				
NPS	DN	L			H	W
		RF	BW	RTJ		
6	150	610	610	613	345	360
8	200	737	737	740	426	460
10	250	838	838	841	495	600
12	300	965	965	968	515	600
16	400	1130	1130	1140	605	600

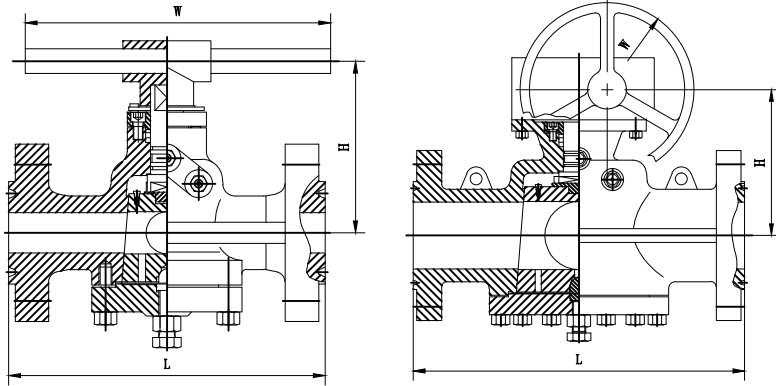

型号 (Model)		X 47W-900LB(圆形全通径)				
压力等级 (Pressure)		900LB				
NPS	DN	L			H	W
		RF	BW	RTJ		
2	50	381	/	384	213	400
2.5	65	432		435	220	500
3	80	470		473	235	600
4	100	559		562	275	600
6	150	737		740	345	360
8	200	813		816	426	460
10	250	965		968	495	600

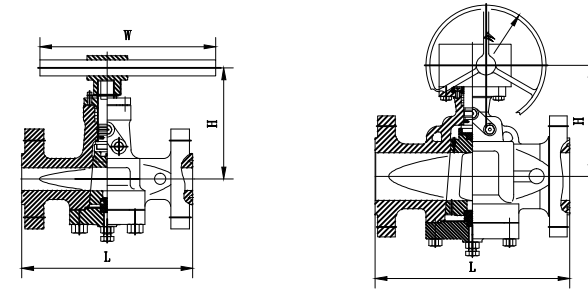

型号 (Model)		X 47W-1500LB(常规型)				
压力等级 (Pressure)		1500LB				
NPS	DN	L			H	W
		RF	BW	RTJ		
2	50	368		371	215	400
2.5	65	419		422	225	500
3	80	470	470	473	245	600
4	100	546	546	549	275	600
6	150	705	705	711	245	360
8	200	832	832	841	426	460
10	250	991	991	1000	495	600

型号 (Model)		X 47W-1500LB(文丘里型)				
压力等级 (Pressure)		1500LB				
NPS	DN	L			H	W
		RF	BW	RTJ		
6	150	705	705	711	345	360
8	200	832	832	841	426	460
10	250	991	991	1000	495	600
12	300	1130	1130	1146	515	600

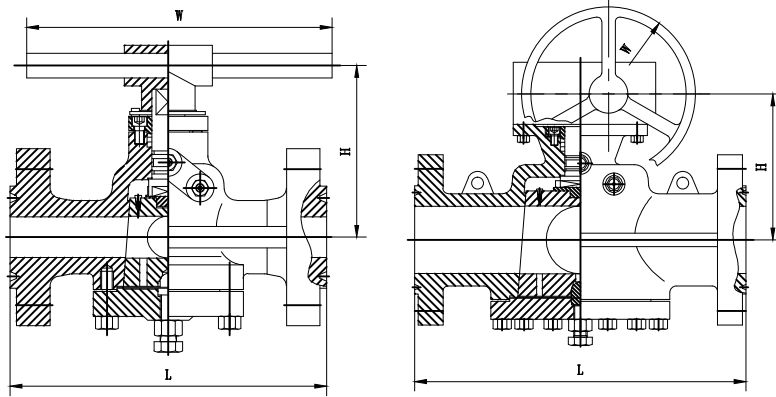

型号 (Model)		X 47W-1500LB(圆形全通径)				
压力等级 (Pressure)		1500LB				
NPS	DN	L			H	W
		RF	BW	RTJ		
2	50	391	/	394	215	400
2.5	65	454		457	225	500
3	80	524		527	245	600
4	100	625		629	285	600
6	150	787		794	355	360
8	200	889		899	435	460
10	250	1067		1076	515	600

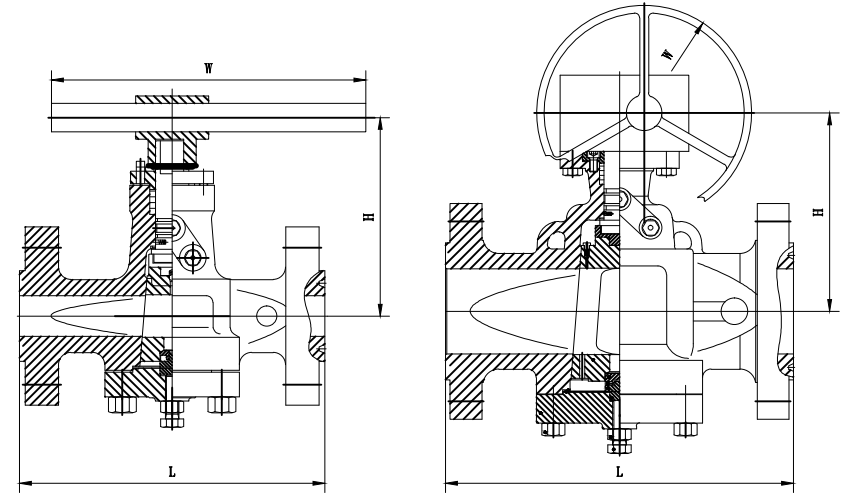

型号 (Model)		X 47W-2500LB(常规型)				
压力等级 (Pressure)		2500LB				
NPS	DN	L			H	W
		RF	BW	RTJ		
2	50	451	/	454	215	400
2.5	65	508		514	235	500
3	80	578		584	245	600
4	100	673		683	295	600
6	150	914		927	365	360
8	200	1022		1038	435	460
10	250	1270		1292	515	600

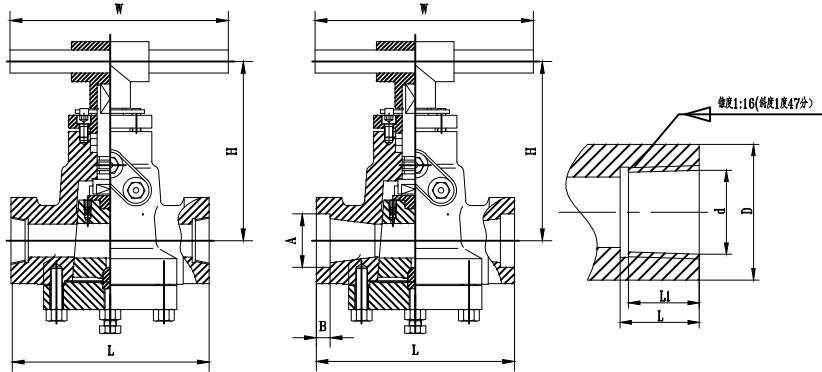

型号 (Model)	X 1 (6) 7F- (150-800LB)					
压力等级 (Pressure)	150-800LB					
口径 (Size)	DN	15	20	25	40	50
	in	1/2	3/4	1	1 1/2	2
L	SW	89	133	133	229	229
	NPT	89	133	133	229	229
	BW	89	133	133	229	229
SW	A	21.7	27.1	33.8	48.6	61.1
	B	9.6	12.7	12.7	12.7	15.8
NPT	d	18.48	23.67	29.87	44.7	56.74
	L	17	17	20	23	23
	L1	14	14	17	20	20
	螺距 (pitch)	1.814	1.814	2.209	2.209	2.209
	每英寸牙数 (Number of teeth per inch)	14	14	11.5	11.5	11.5
H	108	127	127	174	174	
W	400	400	500	600	800	

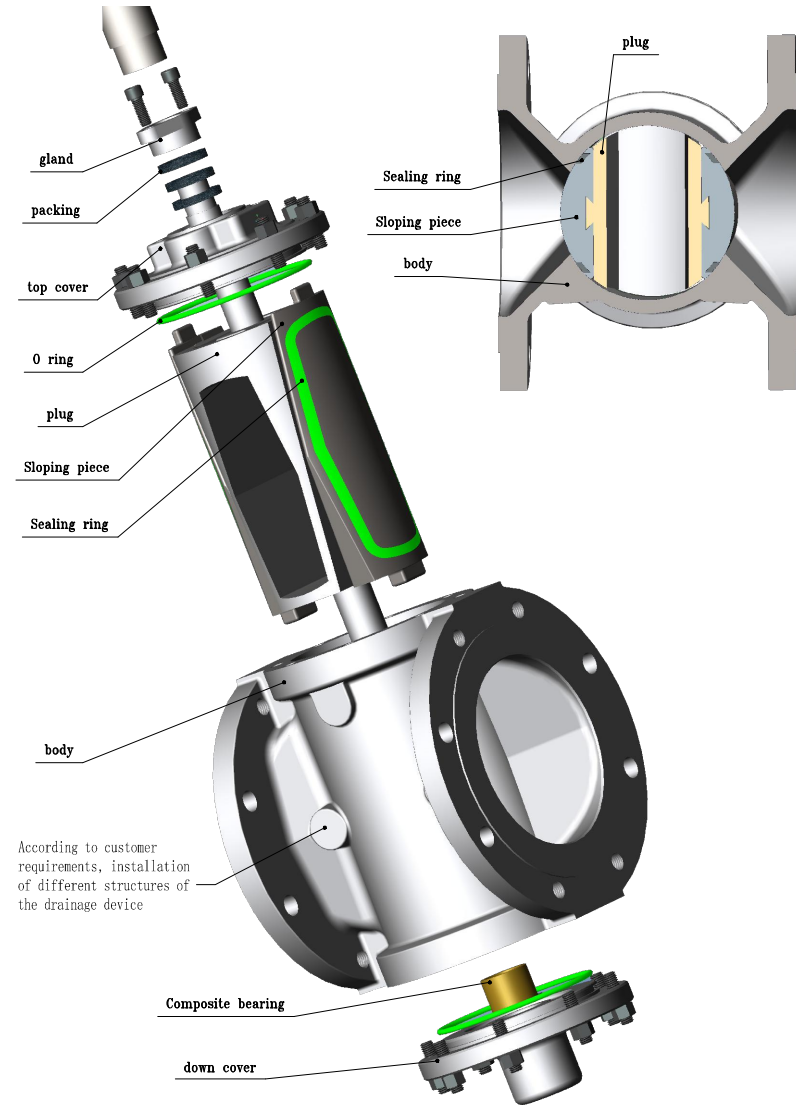

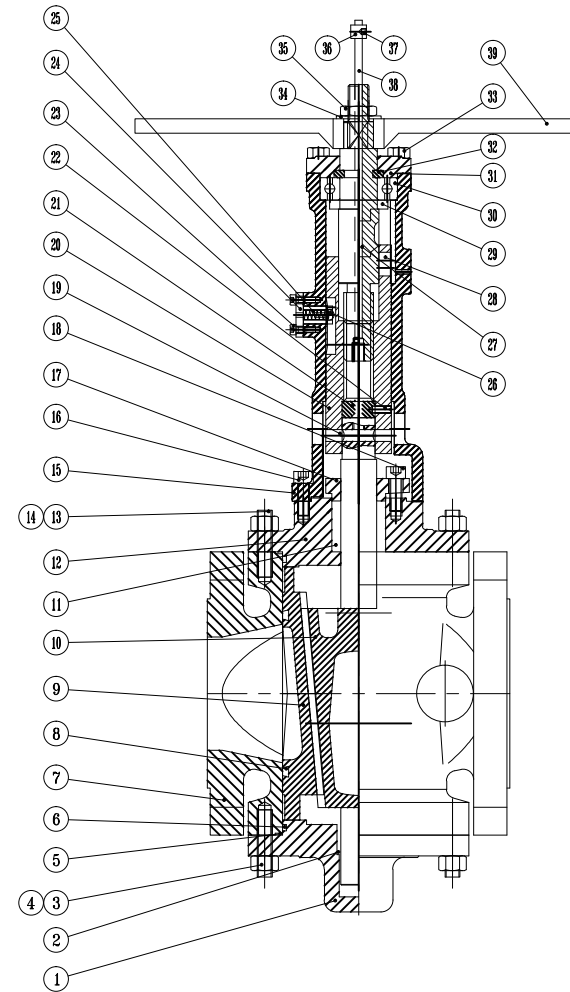
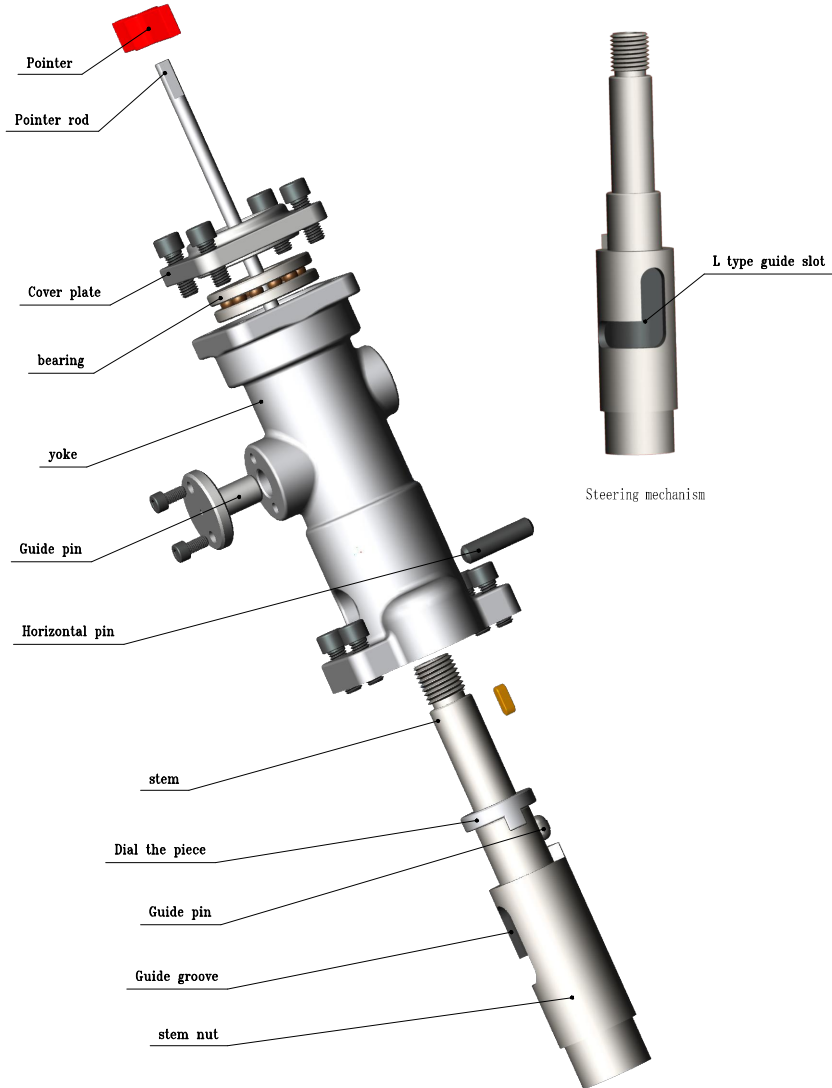

主要零部件材质 Material of main parts

序号 NO	名称 Part Name	材质 material
1	下阀盖 Down cover	A216 WCB/A351 CF8/CF8M/CF3/CF3M
2	复合轴承 Composite bearing	SF
3	螺栓 Blot	A193 B7/8/8M
4	螺母 Nut	A194 2H/8/8M
5	垫片 Gasket	SS304+Graphite
6	O型圈 O-rings	Viton
7	阀体 Body	A216 WCB/A351 CF8/CF8M/CF3/CF3M
8	密封圈 Sealing ring	Viton
9	斜滑片 Sloping piece	A216 WCB/A351 CF8/CF8M/CF3/CF3M
10	旋塞 Plug	A216 WCB/A351 CF8/CF8M/CF3/CF3M
11	填料 Packing	Graphite
12	上阀盖 Up cover	A216 WCB/A351 CF8/CF8M/CF3/CF3M
13	螺栓 Blot	A193 B7/8/8M
14	螺母 Nut	A194 2H/8/8M
15	支架 Yoke	A216 WCB
16	内六角螺钉 Hexagon socket screw	A193 B7
17	填料压盖 Gland	A216 WCB/A351 CF8/CF8M/CF3/CF3M
18	内六角螺钉 Hexagon socket screw	A193 B7
19	横销 Horizontal pin	410/4140
20	阀杆螺母 Stem nut	D2
21	垫座 chock	SS
22	螺钉 screw	A193 B7
23	内六角螺钉 Hexagon socket screw	A193 B7
24	封盖 block	C. S.
25	弹簧 Spring	SS304
26	导向销 Guide pin	SS410/4140
27	阀杆 Stem	SS410/
28	导向球 Guide the ball	SS410/
29	拨块 Dial the piece	SS410/
30	轴承 bearing	组合件 assembly
31	盖板 Cover plate	A216 WCB
32	对开环 Split ring	SS410
33	螺钉 screw	A193 B7
34	垫片 Gasket	SS304
35	锁紧螺母 Lock nut	1035
36	指针 Pointer	SS304
37	紧定螺钉 Set screw	SS304
38	指针杆 Pointer rod	SS
39	手轮 handwheel	A216 WCB

工作原理 operating principle

轨道式旋塞阀的密封件（滑块）与旋塞的连接采用导轨式结构。阀门在开启的过程中，先通过传动机构将旋塞提升到一定高度（设计给定），随着旋塞的提升，两只滑块逐步被旋塞向阀门中心拉回，当滑块密封面完全脱离阀体密封面并形成一定的间隙（设计给定），继续通过传动机构使旋塞与滑块在一起选装90°到阀门开启。阀门在关闭过程中，先通过传动机构使旋塞与滑块一起旋转90°（阀门处于关闭状态，但未形成密封），继续通过传动机构将旋塞推下，随着旋塞的向下移动，从而推动滑块向阀体两边密封面靠拢，直至滑块上的弹性密封圈被均匀地挤压到阀体两端的密封面上，形成密封。

The connection between the sealing element (slide block) and the cock of the rail-type cock adopts the guide-rail structure. Valves in the process of opening, first through the drive mechanism (design) given cock ascend to a certain height, as the cock, two slider is gradually cock center back to the valve, when the slider seal face completely out of the clearance of valve sealing surface and forms a certain given (design), to continue through the drive mechanism make the cock with slider options 90° to open valve. Valves in the process of closing, the first through the drive mechanism make the cock rotate 90° with the slider (valve is closed, but did not form a seal), to continue through the drive mechanism to push the cock, as the cock moves down, pushing the slider to on both sides of the body seal face, until the elastic sealing ring of the slider will be evenly squeeze into the body on both sides of the seal surface, form a seal.

产品结构特点 Product structure features

1、中法兰双重密封结构 轨道式旋塞阀大部分用于航空煤油、天然气、液化石油气、成品油等，由于航空煤油等介质具有很强的渗透性且易燃易爆，为杜绝介质外泄露，在中法兰处采用O型圈加缠绕垫片双重密封结构。

2、填料密封结构，轨道式旋塞阀的阀芯在阀门开关过程中，既要上下移动又要进行旋转运动，加上介质的特殊性，为保证填料密封安全可靠采用内外O型圈与填料组合密封

3、阀门的操作机构及自锁性，轨道旋塞阀的操作机构（螺套）采用独特的L形槽结构，将旋塞的轴向直线移动和90°旋转运动分开，使阀门操作灵活、轻便。

1, the middle flange double seal structure rail plug valve is mostly used for aviation kerosene, natural gas, liquefied petroleum gas, product oil, etc., because aviation kerosene and other media has a strong permeability and flammable and explosive, in order to prevent leakage of the medium, in the middle flange using o-ring and winding gasket double seal structure.

2, packing seal structure, orbital plug valve spool in the valve switch process, both up and down to move and rotary movement, plus the particularity of the medium, in order to ensure the packing seal safe and reliable use of o-ring and packing combination seal

3, operating mechanism of the valve and self-locking, the cock valve operating mechanism (screw) adopts unique l-shaped slot structure, move the cock of the axial line and 90° rotation apart, make the valve operation is flexible, lightweight.

4、关键零部件的特殊工艺处理，阀体内腔机械加工后（磨削），经镀硬铬处理，使阀体内腔具有耐锈蚀、耐冲刷、耐磨损、耐腐蚀性能。滑块机械加工后（压氟橡胶前）经镀硬铬处理，使滑块金属密封面具有耐锈蚀、耐冲刷、耐磨损、耐腐蚀性能。旋塞机械加工后，经镀镍处理，旋塞及上下轴耐锈蚀、耐腐蚀。阀杆粗加工后，进行调质处理，精加工后进行渗氮处理，表面硬度不低于900HV，提高了与螺套的抗咬及抗磨损性能。螺套上的L形导向槽及导向键头部加工后进行淬火处理，不低于45HRC，提高了耐磨损性能，保证了导向键能在导向槽内自由滑动。

5、填料的在线调整和维修，轨道旋塞阀在支架两侧面开有进行填料调整和维修的窗口，

6、整体旋塞结构，轨道旋塞阀的旋塞采用整体铸造结构。旋塞与上、下轴为一整体，单向受压时，确保上下轴具有足够的刚度和强度及抗弯曲性。

4, special processing of key parts, the valve body cavity mechanical processing (grinding), after hard chromium plating treatment, the valve body cavity with corrosion resistance, erosion resistance, wear resistance, corrosion resistance. After mechanical processing of slide block (before pressing fluorine rubber), the slide block metal sealing surface is treated by hard chromium plating, so that it has the properties of corrosion resistance, erosion resistance, wear resistance and corrosion resistance. After the mechanical processing of the cock, after nickel plating treatment, the cock and the upper and lower shaft corrosion resistance, corrosion resistance. After rough machining, the valve stem is treated by tempering and tempering, and the surface hardness is no less than 900HV after finishing, which improves the anti-bite and anti-wear performance of the screw sleeve. The l-shaped guide groove and the head of the guide key on the screw sleeve are processed and then quenched, no less than 45HRC, which improves the wear resistance and ensures that the guide key can slide freely in the guide groove.

5. Online adjustment and maintenance of packing. The track cock has a window for adjustment and maintenance of packing on both sides of the support.

6. Integral cock structure. The cock of track cock valve adopts integral casting structure. The cock is integrated with the upper and lower axes. When unidirectional compression is applied, ensure the upper and lower axes have enough rigidity, strength and bending resistance.

7、阀门中腔超压泄放功能，泄放的压差是因为环境温度的变化而产生的。双密封阀门在关闭状态下，阀门中腔积存的介质随环境温度的升高体积膨胀，压力逐步升高，如果不及时泄放掉该压差，将会对阀门的操作产生严重影响，甚至会出现阀门的胀裂，给系统的安全造成严重隐患。轨道式旋塞阀通常有三种泄压系统。

7.1、手控泄压系统（用于手动操作阀门）。通常为安装在阀体上的针型阀。当阀门关闭后，开启中腔压力泄放阀，将阀体中腔介质泄到管道上游或大气中（当向大气中泄放时，可以检验阀门的密封效果）

7.2、压差式泄压系统（用于手动、电动操作阀门）。是一带有单向阀（止回阀）的管路系统。隔离阀常开，当阀门关闭后，通过单向阀（止回阀）将阀体中腔的过压泄放到阀门上游与管道接通。同时开启手控泄放阀可以检验阀门的密封效果，阀门开启时必须将手控泄放阀关闭。

7.3、自动泄压系统（用于电动操作阀门）。阀门关闭的同时，通过操作机构将泄压阀自动开启，使阀腔与管道上游或外界连通。

7, the valve cavity overpressure relief function, the pressure difference is caused by the change of environmental temperature. Double sealed valve in the closed state, the valve cavity of the medium with the increase of the ambient temperature volume expansion, pressure gradually increased, if not timely release the pressure difference, will have a serious impact on the operation of the valve, or even the expansion of the valve crack, to the safety of the system caused serious hidden trouble. Rail plug valves usually have three relief systems.

7.1 manual pressure relief system (for manual operation of the valve). Usually needle - type valves mounted on the valve body. When the valve is closed, open the pressure relief valve in the middle chamber, and release the medium in the valve body to the upstream of the pipeline or the atmosphere (check the sealing effect of the valve when releasing to the atmosphere).

7.2 differential pressure relief system (for manual and electric operation of valves). A piping system with a check valve. Isolation valve often open, when the valve is closed, through the one-way valve (check valve) in the body of the overpressure relief to the upstream valve and pipe connected. At the same time, the manual release valve can be opened to test the sealing effect of the valve. When the valve is opened, the manual release valve must be closed.

7.3 automatic pressure relief system (for electrically operated valves). When the valve is closed, the pressure relief valve will be opened automatically through the operating mechanism to connect the valve chamber with the upstream of the pipeline or the outside world.

工作原理示意图 Schematic diagram of working principle

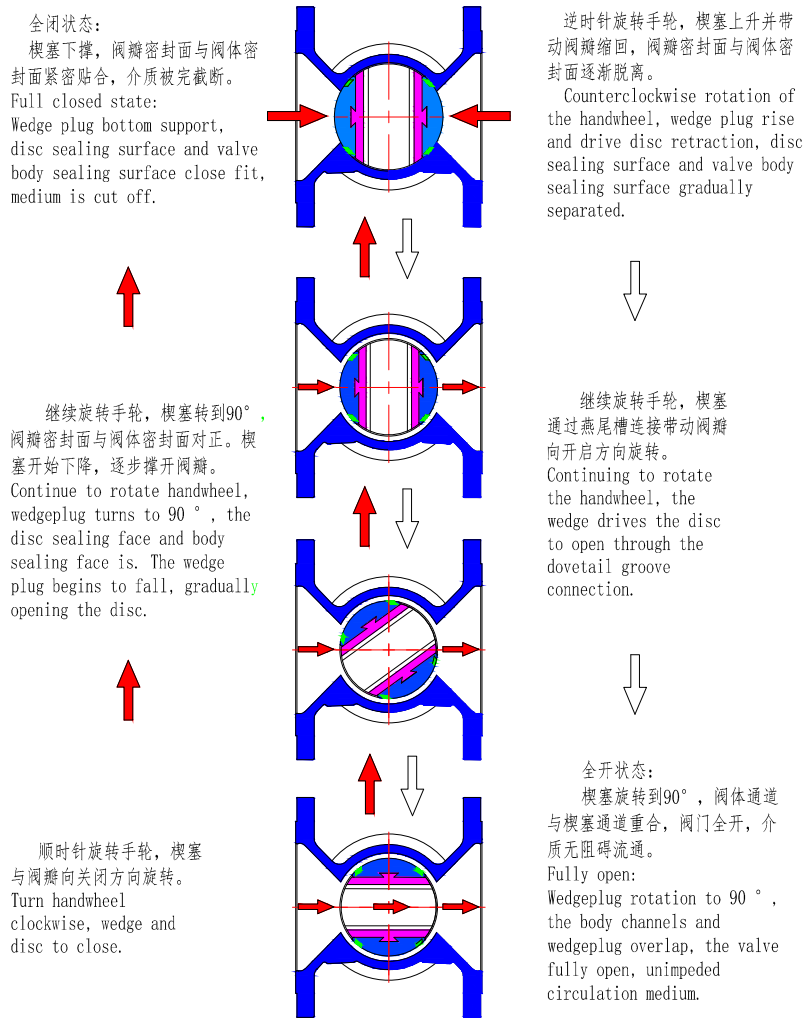

技术规范 The technical specification

结构形式 Structure form	BC
驱动方式 Drive a mode	手动、电动、气动 Manual, electric, pneumatic
设计标准 Design criteria	API6D/API599/BS5353/GB/T22130
结构长度标准 Structural length standard	API6D/ASME B16.10/EN558
法兰连接标准 Flange connection standard	ASME B16.5/EN1092/HG/T20592
对焊连接标准 Welding connection standard	ASME B16.25/B36.10
NPT连接标准 NPT connection standard	ASME B1.20.1
压力温度额定值 Pressure temperature rating	ASME B16.34
检验标准 Inspection standard	API6D/API598
防火标准 Fire protection standard	API607

产品性能规范 Product performance specification

公称压力 (LB) Nominal pressure	壳体实验压力 (Mpa) Shell test pressure	密封试验压力 (Mpa) Seal test pressure	适用温度 (°C) Suitable temperature	适用介质 Applicable medium
150	3.0	2.2	≤180°C	水、蒸气、油品 Water, steam, oil
300	7.5	5.5		
600	15.0	11.0		
900	22.5	16.5		

DBB式旋塞阀
DBB plug valve

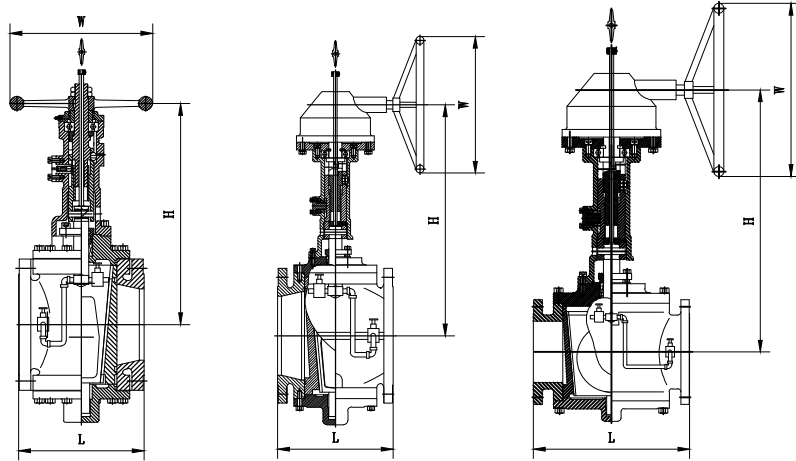

NPS	DN	150LB					300LB				
		L			H	W	L			H	W
		short pattern	reduced bore	full bore			short pattern	reduced bore	full bore		
2	50	178		267	365	250	216		283	365	250
3	80	203		343	385	250	283		387	385	250
4	100	229		432	406	300	305		457	406	300
6	150	267		546	483	380	403		559	483	380
8	200	292		622	650	460	419		686	650	460
10	250	330		660	730	460	457		826	730	460
12	300	356		762	750	460	502		965	750	460
14	350	381			810	460		762		810	460
16	400	406			850	500		838		850	500
18	450		864		920	600		914		920	600
20	500		914		960	600		991		960	600
24	600		1067		1120	600		1320		1120	600

DBB式旋塞阀
DBB plug valve

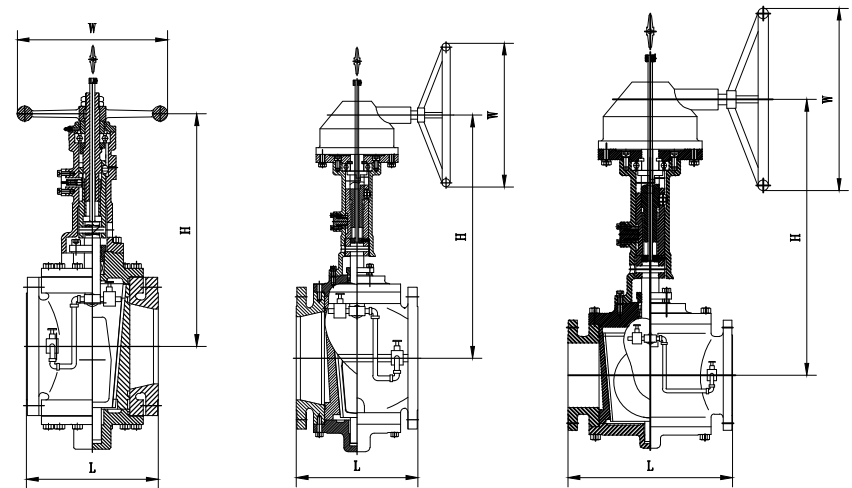

NPS	DN	600LB					900LB				
		L			H	W	L			H	W
		short pattern	reduced bore	full bore			short pattern				
2	50	292		330	430	320	368			515	460
3	80	356		445	445	320	381			580	460
4	100	432		508	525	320	457			625	460
6	150	559		660	655	460	610			710	500
8	200	660		794	760	460	737			905	720
10	250		787	940	920	720	838			1065	860
12	300		838	1067	950	720					
14	350		889		965	720					
16	400		991		1130	860					
18	450		1029		1150	860					
20	500		1194		1330	860					
24	600		1397		1405	860					