

PK200
Current-to-Pneumatic Converter
[Style:S2]

IM 21B03D01-01E

vigilantplant.[®]

PK200

Current-to-Pneumatic Converter

[Style:S2]

IM 21B03D01-01E 13th Edition

Contents

◆	Introduction.....	iii
1.	Handling Precautions	1-1
1.1	Checking the Model Suffix Code and Specifications	1-1
1.2	Transportation Precautions	1-1
1.3	Storage Precautions	1-1
1.4	Precautions for Installation Area.....	1-2
1.5	Installation of Intrinsically Safe Type.....	1-2
1.5.1	CSA Intrinsically Safe Type.....	1-2
1.5.2	TIIS Intrinsically Safe Type	1-2
1.6	Installation of Flameproof Type.....	1-3
1.6.1	TIIS Flameproof Type	1-3
1.6.2	FM Explosionproof Type	1-3
1.7	EMC Conformity Standard	1-4
2.	Overview.....	2-1
2.1	Functional Description.....	2-1
2.2	Standard Specifications.....	2-1
2.3	Model and Suffix Codes	2-3
2.4	Options.....	2-3
2.5	External Dimensions	2-4
2.6	Part Names	2-4
3.	Installation.....	3-1
3.1	Overview	3-1
3.2	Installation	3-1
3.2.1	Pipe Mounting	3-1
3.2.2	Wall Mounting	3-1

4.	Wiring and Piping	4-1
4.1	Piping	4-1
4.1.1	Supply Air	4-1
4.1.2	Air Supply Piping	4-1
4.1.3	Output Piping	4-1
4.2	General-Use and Flameproof Type Wiring	4-1
4.2.1	Cable Selection	4-1
4.2.2	Wiring	4-2
4.2.3	Grounding	4-4
4.3	Intrinsically Safe Type Wiring	4-4
5.	Operation	5-1
5.1	Auto/Manual (A/M) Transfer Mechanism	5-1
5.2	Zero Point Adjustment	5-1
5.3	Calibration	5-2
5.4	Range Adjustment	5-4
5.5	4 to 20mA/10 to 50mA Selection	5-4
6.	Maintenance	6-1
6.1	Overview	6-1
6.2	Periodic Inspection	6-1
6.2.1	Cleaning the Restrictor	6-1
6.3	Parts Replacement	6-2
6.3.1	Replacing the Screen Filter	6-2
6.3.2	Replacing the Controller Relay	6-2
6.3.3	Replacing the Amplifier Assembly	6-2
7.	Troubleshooting	7-1
7.1	Overview	7-1
7.2	Operation Principle	7-1
7.3	Troubleshooting Flow	7-2
Appendix A. Air Supply System		A-1
Installation and Operating Precautions for TIIS Intrinsically Safe Equipment		
.....		EX-A03E
Installation and Operating Precautions for TIIS Flameproof Equipment		
.....		EX-B03E
Customer Maintenance Parts List		
Model PK200 Current-to-Pneumatic Converter		CMPL 21B03D01-01E
Revision Information		

◆ Introduction

Thank you for purchasing the Current-to-Pneumatic Converter.

The Current-to-Pneumatic Converter is correctly calibrated at the factory before shipment. To ensure correct and efficient use of the instrument, please read this manual thoroughly and fully understand how to operate the instrument before operating it.

■ Regarding This Manual

- This manual should be passed on to the end user.
- The contents of this manual are subject to change without prior notice.
- All rights reserved. No part of this manual may be reproduced in any form without Yokogawa's written permission.
- Yokogawa makes no warranty of any kind with regard to this manual, including, but not limited to, implied warranty of merchantability and fitness for a particular purpose.
- If any question arises or errors are found, or if any information is missing from this manual, please inform the nearest Yokogawa sales office.
- The specifications covered by this manual are limited to those for the standard type under the specified model number break-down and do not cover custom-made instrument.
- Please note that changes in the specifications, construction, or component parts of the instrument may not immediately be reflected in this manual at the time of change, provided that postponement of revisions will not cause difficulty to the user from a functional or performance standpoint.

■ Safety Precautions

- For the protection and safety of the operator and the instrument or the system including the instrument, please be sure to follow the instructions on safety described in this manual when handling this instrument. In case the instrument is handled in contradiction to these instructions, Yokogawa does not guarantee safety.
- Yokogawa will not be liable for malfunctions or damage resulting from any modification made to this instrument by the customer.

- For the intrinsically safe equipment and explosionproof equipment, in case the instrument is not restored to its original condition after any repair or modification undertaken by the customer, intrinsically safe construction or explosionproof construction is damaged and may cause dangerous condition. Please contact Yokogawa for any repair or modification required to the instrument.
- The following safety symbol marks are used in this Manual:



WARNING

Indicates a potentially hazardous situation which, if not avoided, could result in death or serious injury.



CAUTION

Indicates a potentially hazardous situation which, if not avoided, may result in minor or moderate injury. It may also be used to alert against unsafe practices.



IMPORTANT

Indicates that operating the hardware or software in this manner may damage it or lead to system failure.



NOTE

Draws attention to information essential for understanding the operation and features.

Warranty

- The warranty shall cover the period noted on the quotation presented to the purchaser at the time of purchase. Problems occurred during the warranty period shall basically be repaired free of charge.
 - In case of problems, the customer should contact the Yokogawa representative from which the instrument was purchased, or the nearest Yokogawa office.
 - If a problem arises with this instrument, please inform us of the nature of the problem and the circumstances under which it developed, including the model specification and serial number. Any diagrams, data and other information you can include in your communication will also be helpful.
 - Responsible party for repair cost for the problems shall be determined by Yokogawa based on our investigation.
-
- **The Purchaser shall bear the responsibility for repair costs, even during the warranty period, if the malfunction is due to:**
 - Improper and/or inadequate maintenance by the Purchaser.
 - Failure or damage due to improper handling, use or storage which is out of design conditions.
 - Use of the product in question in a location not conforming to the standards specified by the Yokogawa, or due to improper maintenance of the installation location.
 - Failure or damage due to modification or repair by the party except Yokogawa or who is requested by Yokogawa.
 - Malfunction or damage from improper relocation of the product in question after delivery.
 - Reason of force majeure such as fires, earthquakes, storms/floods, thunder/lightening, or other natural disasters, or disturbances, riots, warfare, or radioactive contamination.

1. Handling Precautions



IMPORTANT

For installation, wiring and maintenance in hazardous areas, please follow 1.5 Installation of Intrinsically Safe Type, 1.6 Installation of Flameproof Type and “Installation and Operating Precautions for TIIS Intrinsically Safe Equipment and TIIS Flameproof Equipment” at the end of this manual.

The PK200 current-to-pneumatic converter is fully factory inspected before shipment. When the instrument is delivered, visually check the instrument and accessories to ensure that they are not damaged. This chapter describes the handling precautions, read them carefully before using the instrument.

For items other than those described in this chapter, see the relevant items.

If you wish to make inquiry, contact the distributor where you purchased the instrument or the nearest YOKOGAWA service station.

1.1 Checking the Model Suffix Code and Specifications

The data plate on the side face of the instrument base shows the model suffix code and specifications. With reference to the model suffix code and specifications in section 2.3, confirm that the instrument is as specified by the order.

For inquiry, inform us of the model suffix code and instrument serial number.

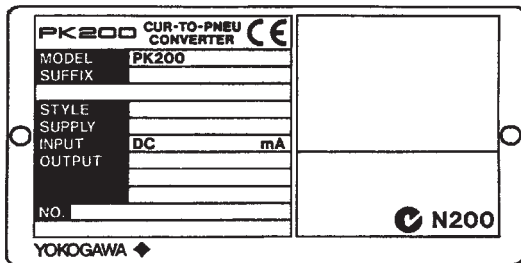

Figure 1.1 Data Plate for General-Use Type

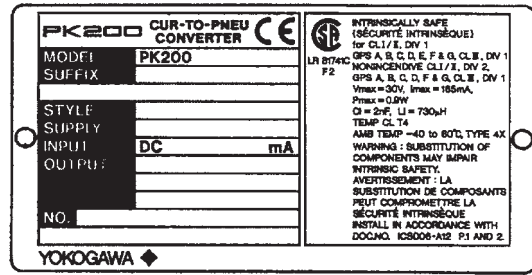

Figure 1.2 Data Plate for CSA Intrinsically Safe Type

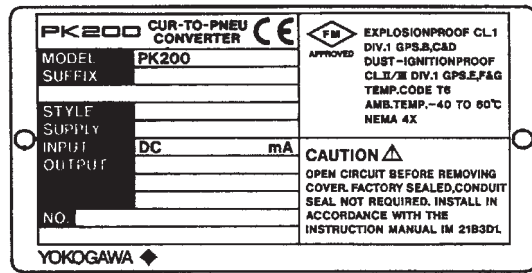

Figure 1.3 Data Plate for FM Explosionproof Type

1.2 Transportation Precautions

To prevent damage occurring during transportation, transport the converter in the original shipping container (box) with all packing items and equipment in its proper position.

1.3 Storage Precautions

- (1) Select a storage place :
 - Which is protected from rain and water.
 - Which is free from vibration and impact.
 - Whose temperature and humidity are as specified below. Room temperature and humidity (approx. 25°C and 65%) are more recommendable.
 - Temperature: -10 to 60°C
 - Humidity: Less than 80%
- (2) Store the converter in the packing condition of shipment from YOKOGAWA whenever possible.

1.4 Precautions for Installation Area

To use the converter stably for a long time, determine an installation place, taking into account the following.

- (1) Ambient Temperature
Avoid installing the instrument in a place subject to a large temperature gradient and variations. If the instrument is subject to plant-generated heat radiation, take measures such as provision of heat protection and good ventilation.
- (2) Atmospheric Conditions
Avoid installing the converter in corrosive atmosphere. Should it be used in corrosive atmosphere, make provision for maintaining good ventilation.
- (3) Magnetic Field
Please contact us in the case this instrument is installed the strong Magnetic Field.

1.5 Installation of Intrinsically Safe Type

1.5.1 CSA Intrinsically Safe Type

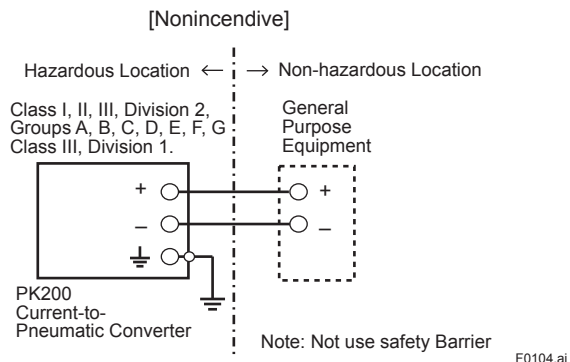
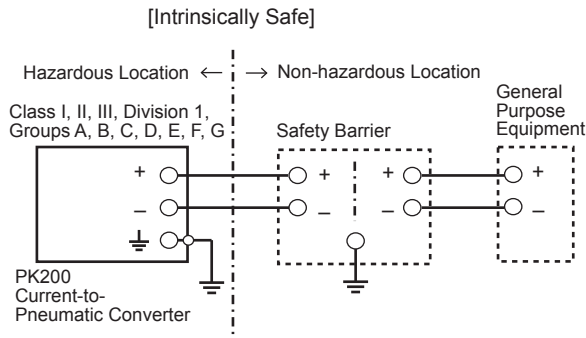

Figure 1.4 Installation of CSA Intrinsically Safe Type

1. PK200 current to pneumatic converter is applicable for use in hazardous locations:
 - Intrinsically Safe for Class I, Division 1, Groups A, B, C & D, Class II, Division 1, Groups E, F & G and Class III, Division 1 Hazardous Locations.
 - Nonincendive for Class I, Division 2, Groups A, B, C & D, Class II, Division 2, Groups F & G, and Class III, Division 1 Hazardous Locations.
 - Outdoor Hazardous Locations, Encl Type 4X.
 - Temperature Class: T4
 - Ambient Temperature: -40 to 60°C
2. Entity Parameters
 - Intrinsically safe apparatus parameters
 - Vmax = 30V
 - I_{max} = 165mA
 - Pmax = 0.9W
 - Ci = 2nF
 - Li = 730μH
 - Associated apparatus parameters (CSA Certified Barriers)
 - Voc ≤ 30V
 - Isc ≤ 165mA
 - Pmax ≤ 0.9W
3. Installation
 - Control equipment connected to barrier must not use or generate more than 250 Vrms or Vdc.
 - The safety barrier must be CSA certified.
 - Associated apparatus manufacturer's installation drawing must be followed when installing this apparatus.
 - The maximum power delivered from the barrier must not exceed 0.9 W.
 - Note a warning label worded "SUBSTITUTION OF COMPONENTS MAY IMPAIR INTRINSIC SAFETY" and "INSTALL IN ACCORDANCE WITH DOC. NO. ICS006-A12 P.1 AND 2".

1.5.2 TIIS Intrinsically Safe Type

The model PK200/JS3 current-to-pneumatic converters, which have obtained certification according to technical criteria for explosion-protected construction of electric machinery and equipment (Standards Notification No.556 from the Japanese Ministry of Labor) conforming to IEC standards, is designed for hazardous areas where explosive gases and/or inflammable vapors may be present. (This allows installation in Division 0, 1 and 2 areas)

To preserve the safety of flameproof equipment requires great care during mounting, wiring, and piping. Safety requirements also place restrictions on maintenance and repair activities. Users absolutely must read the following instructions and “Installation and Operating Precautions for TIIS Intrinsically Safe Equipment (EX - A03E)” at the end of this manual.

1. Installation

The PK200 Current-to-Pneumatic Converter should be used in connection with the certified safety barrier as shown below. All wiring shall comply with local installation requirements.

[Installation Diagram]

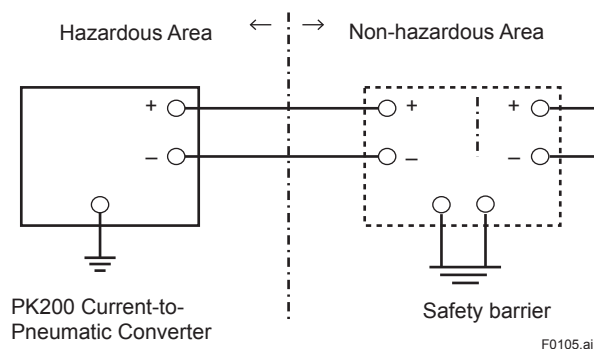

2. Temperature

Install the PK200, So that any part of the instrument that may be exposed to the inflammable gas or vapor would not exceed the temperature 60°C

3. Safety Barrier

Use the certified safety barrier that satisfies the following requirements.

- Safety Ratings
 - Maximum output voltage: 28V or less
 - Maximum output current: 94.3mA or less
 - Maximum output power: 0.66W or less
- Protection type and group
 - Protection type: ia Group: IIC
- Allowable inductance and capacitance
 - Maximum_external inductance:
 - More than the external wiring inductance
 - Maximum_external capacitance:
 - More than the sum of the external wiring capacitance and 39nF

Table 1.1 Recommended Safety Barrier
Contact each supplier for the details of the barrier.

Supplier	Type	Model
MTL	Isolated type	MTL5046
P+F	Isolated type	KFD2-SCD-Ex1.LK*

* To connect this barrier with PK200 converter, for the connection between the barrier and the controller, use the terminal #7 and #9 of the barrier.

1.6 Installation of Flameproof Type

1.6.1 TIIS Flameproof Type

The model PK200/JF3 current-to-pneumatic converters, which have obtained certification according to technical criteria for explosion-protected construction of electric machinery and equipment (Standards Notification No.556 from the Japanese Ministry of Labor) conforming to IEC standards, is designed for hazardous areas where explosive gases and/or inflammable vapors may be present. (This allows installation in Division 1 and 2 areas)

To preserve the safety of flameproof equipment requires great care during mounting, wiring, and piping. Safety requirements also place restrictions on maintenance and repair activities. Users absolutely must read “Installation and Operating Precautions for TIIS Flameproof Equipment (EX-B03E)” at the end of this manual.

1.6.2 FM Explosionproof Type

Following items are described in the instruction documents of this instrument to ensure certified explosionproof properties.

1. PK200 Current to Pneumatic Converter is applicable for use in hazardous areas;
 - * Explosionproof for Class I, Division 1, Groups B, C and D.
 - * Dust ignitionproof for Class I/II, Division 1, Groups E, F and G.
 - * Outdoor hazardous locations, NEMA 4X.
2. Wiring
 - * All wiring shall comply with National Electrical Code ANSI/NEPA70 and Local Electrical Codes.
 - * When installed in Division 1, “FACTORY SEALED, CONDUIT SEAL NOT REQUIRED”. However, in case of installing a sealing fitting (option) for waterproof or other purposes, see 4.2.2(6).
3. Operation
 - * **WARNING: OPEN CIRCUIT BEFORE REMOVING COVER.**
FACTORY SEALED, CONDUIT SEAL NOT REQUIRED.
INSTALL IN ACCORDANCE WITH THE INSTRUCTION MANUAL IM 21B3D1-01E

- * Take care not to generate mechanical spark when access to the instrument and peripheral devices in hazardous location.
4. Maintenance and Repair
- * The instrument modification or parts replacement by other than authorized representative of Yokogawa Electric Corporation is prohibited and will void Factory Mutual Explosionproof Certification.

1.7 EMC Conformity Standard

EN61326-1 Class A, Table 2

(For use in industrial locations)

Immunity influence during the test:

Output shift is specified within $\pm 1\%$ of span.



CAUTION

To meet EMC regulations, Yokogawa recommends that customers run signal wiring through metal conduits or use shielded twisted-pair cabling when installing this instrument in a plant.



CAUTION

This instrument is a Class A product, and it is designed for use in the industrial environment. Please use this instrument in the industrial environment only.

2. Overview

2.1 Functional Description

The PK200 current-to-pneumatic converter is a signal converter that receives an electronic controller or DCS control signal and converts it into a pneumatic pressure signal.

2.2 Standard Specifications

Materials:

- Case: Aluminum die-cast
- Paint: Polyurethane resin-baked finish
- Paint color: Deep-sea moss-green (Munsell 0.6GY3.1/2.0 or equivalent)
- Pressure Gauge Case: Stainless steel JIS SUS304

Input Signals:

4 to 20mA DC or 10 to 50mA DC

Input Resistance:

PK200 is not a constant resistor.

Equivalent circuit of PK200 is shown in Figure 2.1

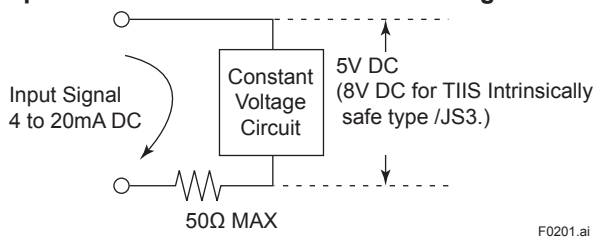

Figure 2.1 Equivalent Circuit

Operating Voltage:

Input Signal	Min.	Max.
4 to 20mA (except /JS3)	5.2V (at 4mA)	6.0V (at 20mA)
4 to 20mA (for /JS3)	8.2V (at 4mA)	9.0V (at 20mA)
10 to 50mA	5.35V (at 10mA)	6.75V (at 50mA)

Output Signals:

See Table 2.1

I/O Action:

Output pressure increases as input increases.

Manual Operation:

Available using auto/manual (A/M) transfer switch (Optional)

Zero Point Adjusting Range:

Within 0 to ±10% of span

Span Adjusting Range:

Within 100 to 125% of span

Air Consumption:

4NI/min maximum (for a supply air pressure of 140kPa)

Max. Air Delivery:

110NI/min maximum (for a supply air pressure of 140kPa)

Minimum Load Capacity:

1m copper tube with 4mm I.D. +20cc

Ambient Temperature:

- 40 to 80°C (for general use)
- 20 to 60°C (TIIS Explosionproof, TIIS Intrinsically safe type)
- 40 to 60°C (for FM Explosionproof, CSA Intrinsically safe type)

Water Proof Construction:

- IEC IP54
- NEMA type 4X

Intrinsically Safe Construction:

- CSA Intrinsically Safe (/CS1):
 - Intrinsically Safe for Class I, Division 1, Groups A, B, C & D Class II, Division 1, Groups E, F & G and Class III, Division 1 Hazardous Locations.
 - Nonincendive for Class I, Division 2, Groups A, B, C & D, Class II, Division 2, Groups F & G, and Class III, Division 1 Hazardous Locations.
 - Outdoor Hazardous Locations, Encl Type 4X.
 - Temperature Class: T4
- TIIS Intrinsically Safe (/JS3):
 - Intrinsically Safe Ex ia IIC T4
 - Certificate: TC18266

Explosionproof Construction:

- TIIS Explosionproof (/JF3):
 - Flameproof Exd II B+H₂ T6X
- FM Explosionproof (/FF1):
 - Explosionproof for Class I, Division 1, Groups B, C and D.
 - Dust ignitionproof for Class II/III, Division 1, Groups E, F and G.
 - Temperature Class: T6.
 - Outdoor hazardous locations, NEMA 4X.

Dustproof Construction:

IEC IP54

Connections:

- Air Connection: Rc1/4 or 1/4NPT female
- Electrical Connection: G1/2, G3/4 female or 1/2NPT, 3/4NPT female

Mounting:

- Vertical or horizontal 50mm (2-INCH) pipe mounting
- Wall mounting

Mass (weight):

2.8kg (6.1lb)

Accuracy:

- ±0.5% of span
- Linearity: ±0.2% of span
- Hysteresis: 0.2% of span
- Repeatability: 0.1% of span

Table 2.1 Output Signals

Output Signal	Standard Output		Doubled Output		Recommended Supply Air Pressure*1	Supply Air Pressure Gauge Scale*1
	Output Signal	Pressure Gauge Scale	Output Signal	Pressure Gauge Scale		
Pa calibration	20 to 100kPa	0 to 200kPa	40 to 200kPa	0 to 400kPa	130 to 150kPa	0 to 200kPa
					230 to 260kPa	0 to 400kPa
kgf/cm ² calibration	0.2 to 1.0kgf/cm ²	0 to 2kgf/cm ²	0.4 to 2.0kgf/cm ²	0 to 4kgf/cm ²	1.3 to 1.5kgf/cm ²	0 to 2kgf/cm ²
					2.3 to 2.6kgf/cm ²	0 to 4kgf/cm ²
Bar calibration	0.2 to 1.0bar	0 to 2bar	0.4 to 2.0bar	0 to 4bar	1.3 to 1.5bar	0 to 2bar
					2.3 to 2.6bar	0 to 4bar
P calibration	3 to 15psi	0 to 30psi	6 to 30psi	0 to 60psi	19 to 22psi	0 to 30psi
			3 to 27psi		*2	0 to 60psi

*1: Set supply air pressure in the range given in the upper column for standard output and in the range given in the lower column for multiplied pressure output.

*2: 6 to 30psi output signal; 34 to 37psi, 3 to 27psi output signal; 34 to 36psi.

2.3 Model and Suffix Codes

Model	Suffix Code	Description
PK200	
Input Signal	-A	4 to 20mA DC
	-C	4 to 20mA/10 to 50mA DC selection type
Output Signal	1	Output signal Pa calibration 20 to 100kPa scale 0 to 200kPa
	2	Output signal Pa calibration 40 to 200kPa scale 0 to 400kPa
	3	Output signal kgf/cm ² calibration 0.2 to 1.0kgf/cm ² scale 0 to 2kgf/cm ²
	4	Output signal kgf/cm ² calibration 0.4 to 2.0kgf/cm ² scale 0 to 4kgf/cm ²
	5	Output signal bar calibration 0.2 to 1.0bar scale 0 to 2bar
	6	Output signal bar calibration 0.4 to 2.0bar scale 0 to 4bar
	7	Output signal P calibration 3 to 15psi scale 0 to 30Psi
	8	Output signal P calibration 6 to 30psi scale 0 to 60Psi
	9	Output signal P calibration 3 to 27psi scale 0 to 60Psi
Connections	1	Air connection: Rc 1/4, Electrical connection: G1/2 female
	2	Air connection: Rc 1/4, Electrical connection: G3/4 female
	3	Air connection: 1/4 NPT female, Electrical connection: 1/2NPT female
	4	Air connection: 1/4 NPT female, Electrical connection: 3/4NPT female
Option	/□	See section 2.4.

2.4 Options

- Option Code /JF3: JIS Flameproof
TIIS flameproof Exd II B+H₂ T6X
- Option Code /G11: Packing adapter for TIIS Flameproof
Electrical connection: G1/2 female, Applicable cable
O.D.: 8 to 12mm
- Option Code /G21: Packing adapter for TIIS Flameproof
Electrical connection: G3/4 female, Applicable cable
O.D.: 10 to 16mm
- Option Code /FF1: FM Explosionproof
- Option Code /JS3: TIIS Intrinsically Safe
Applicable only with input signal code-A.
- Option Code /CS1: CSA Intrinsically Safe
- Option Code /SCF-: □ Special Color Finished on converter cover
Allows the paint color of only a converter cover to be selectable by specifying the color in the specification item with reference to GS22D01F01-00EN.
- Option Code /X1: Epoxy Paint
Epoxy resin-baked coating.
Not applicable for special color finished.
- Option Code /L: Lightning Protector
Installed in the terminal box to protect internal circuitry from high voltage surges such as those caused by lightning induced.
- Option Code /AM: AUTO/MANUAL Switch
Mounted on front of housing, in manual mode, output signal is varied by adjusting the external supply pressure regulator.
- Option Code /GW: Double Scale Pressure Gauge
Double scales are kPa and kgf/cm².
- Option Code /SS: Stainless Steel Screw and Bracket Screw and bracket, both are made of stainless steel.
- Option Code /RA: Reverse Action
Increasing of input signal to make output pressure decrease.

2.5 External Dimensions

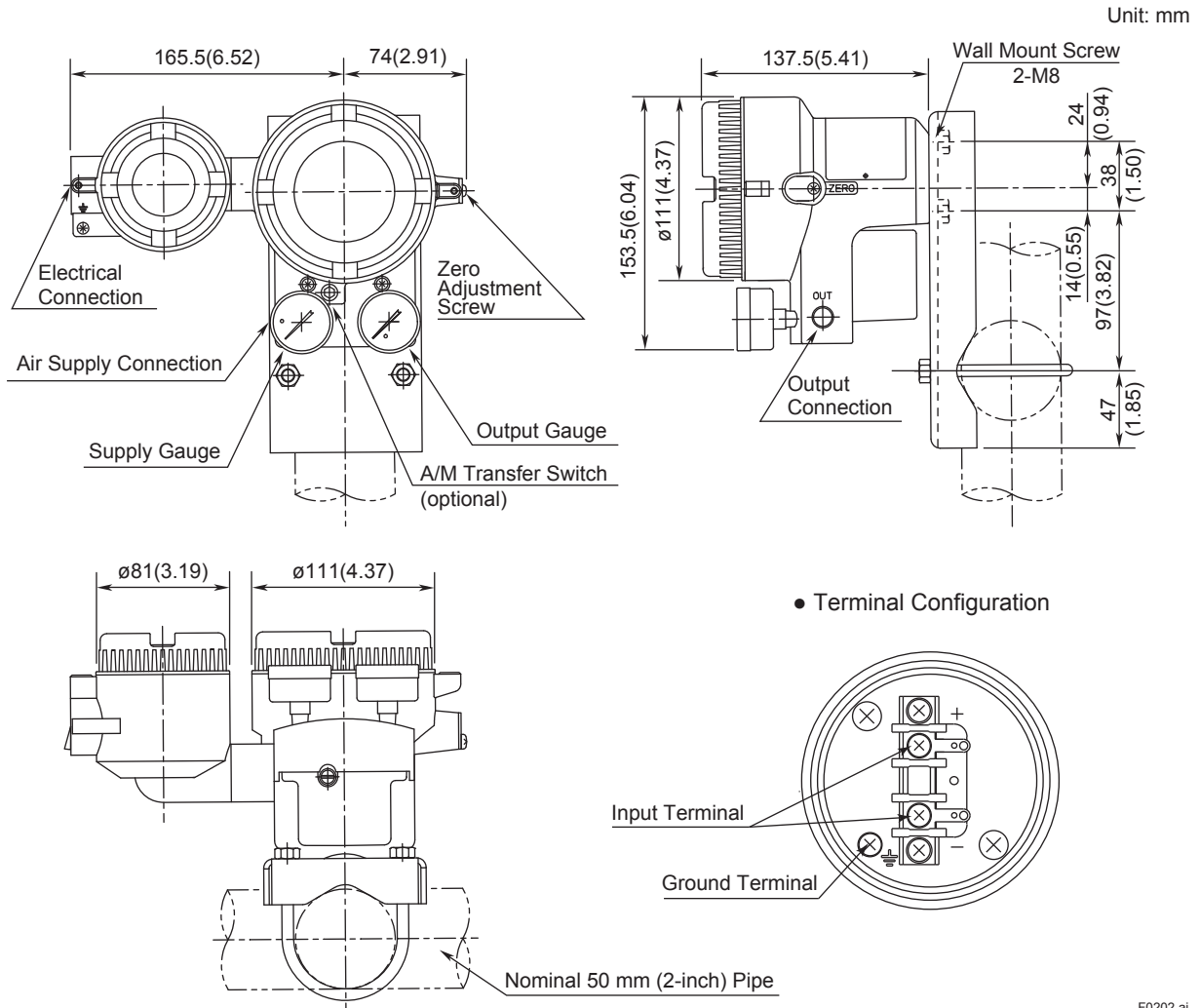

F0202.ai

2.6 Part Names

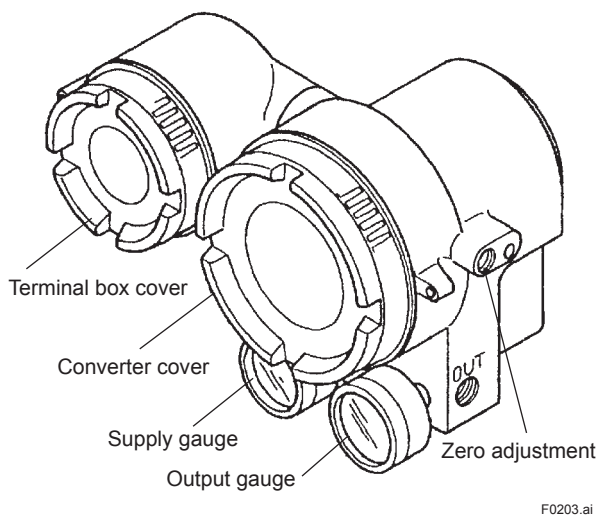

F0203.ai

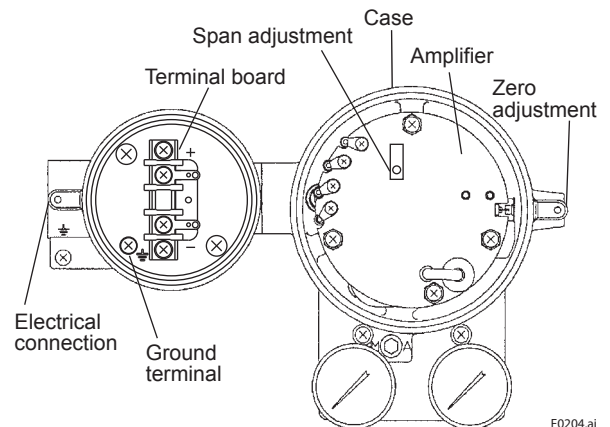

F0204.ai

Figure 2.3 Part Names (1)

Figure 2.4 Part Names (2)

3. Installation

3.1 Overview

When installing the PK200 converter, see section 1.4 “Precautions for Installation Area.” For the ambient environmental conditions of an installation place, see section 2.2 “Standard Specifications.”

3.2 Installation

PK200 can be installed on a pipe using a mounting bracket provided or directly installed on the wall. Select either method, taking into account the installation space and service method.

3.2.1 Pipe Mounting

When this instrument is mounted on a pipe, use the mounting bracket and U-bolt provided. The pipe dia. available is 50mm (2-INCH) and the instrument can be installed on either a horizontal or vertical pipe.

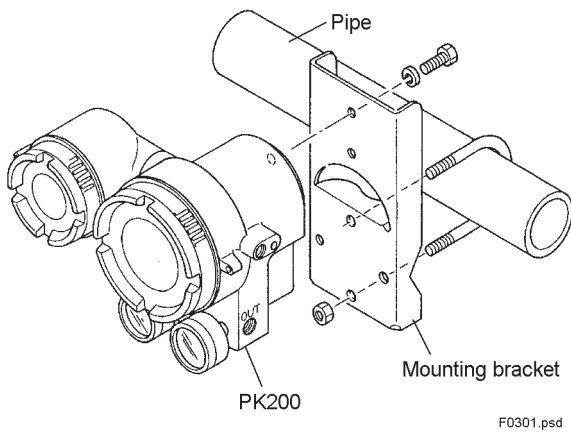

Figure 3.1 Pipe Mounting

3.2.2 Wall Mounting

When the instrument is installed on the wall, use the two M8 screws provided.

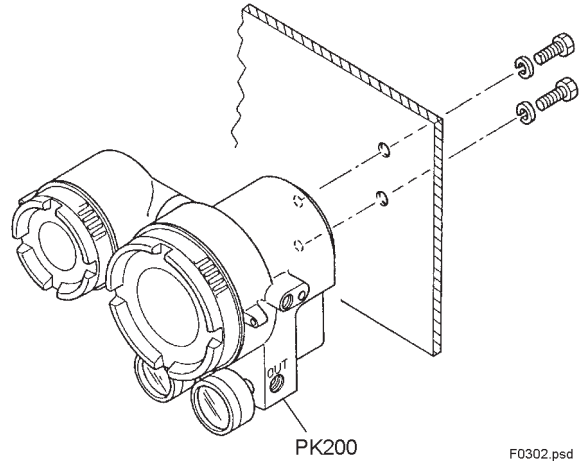

Figure 3.2 Wall Mounting

4. Wiring and Piping

4.1 Piping

4.1.1 Supply Air

For easy operation and maintenance, supply air must be clean and dry.



IMPORTANT

Thoroughly study selection of an air supply system, supply air suction point, installation of the header, and air supply piping so that no water, oil, or dust is carried into the current-to-pneumatic converter via the piping.

Table 4.1 shows the air supply pressure for this instrument.

For air consumption, see the standard specifications.

Table 4.1 Recommended Supply Air Pressure

Output Signal Code	Output Signal	Supply Air Pressure
1	20 to 100kPa	130 to 150kPa
2	40 to 200kPa	230 to 260kPa
3	0.2 to 1.0kgf/cm ²	1.3 to 1.5kgf/cm ²
4	0.4 to 2.0kgf/cm ²	2.3 to 2.6kgf/cm ²
5	0.2 to 1.0bar	1.3 to 1.5bar
6	0.4 to 2.0bar	2.3 to 2.6bar
7	3 to 15psi	19 to 22psi
8	6 to 30psi	34 to 37psi
9	3 to 27psi	34 to 36psi

4.1.2 Air Supply Piping

Connect air supply piping to the supply pressure connection **IN** of the converter.

Generally, use copper tubes of 6mm O.D. and 4mm I.D., air piping, and coupling to install air supply piping. After installing the piping, check for leakage.

4.1.3 Output Piping

Connect output air piping to the output connection **OUT** of the converter.

Generally, use copper tubes of 6mm O.D. and 4mm I.D., air piping, and coupling to install output air piping. After installing the piping, check for leakage.

4.2 General-Use and Flameproof Type Wiring

4.2.1 Cable Selection

- (1) Use twisted wires or cables with performance equal to or better than that of 600V vinyl-insulated cables (JIS C 3307) for wiring cables.
- (2) Use shielded cables for wiring in a place susceptible to noise influence.
- (3) For wiring in an area where high or low ambient temperatures exist, use wires or cables that meet service environment requirements.



IMPORTANT

If the PK200 is flameproof and the ambient temperature is 50°C or more, use an external cable having a maximum allowable heat resistance of at least 70°C in consideration of the instrument's generation of heat or the cable's self-heating.

- (4) For use in an atmosphere where harmful gas, liquid, oil, or solvent exists, use wires or cables with materials sufficiently durable to such substances.

4.2.2 Wiring

- (1) Install wiring away from noise sources such as a large capacity transformer, motor, or power supply.
- (2) Remove terminal box cover and wiring connection dustproof plugs, then connect wiring.
Using an Allen wrench (width 3mm), unscrew the locking setscrew and remove the flameproof cover.
Then, connect the wiring and when installing the cover, do not neglect to fasten shrouding metal.
- (3) It is recommended that clip-on terminals R1.25-5 or R2-5 be used for wiring termination (JIS C 2805).
- (4) It is also recommended that wiring be installed in conduits and ducts to provide protection against water or external damage. For flameproof external wiring, see "1.6 Installation of Flameproof Type" and "Installation and Operating Precautions for TIS Flameproof Equipment" at the end of this manual.
- (5) When installing a flameproof gland packing adapter (option code: /G11 and /G21) for cable wiring, observe the following steps.
 - a. Release the shrouding metal and remove the terminal box cover.
 - b. Measure the outside dia. of the cables to be used in two directions in 0.1mm unit.
 - c. Obtain the average value of the measured values in two directions and select a gland packing whose inner dia. is nearest to the average value from among those in Table 4.1.
 - d. Screw the flameproof packing adapter into the terminal box until the O-ring touches the terminal box wiring port (at least 6 full turns), and tighten the lock nut.

- e. Insert the cable through the union cover, the union coupling, the clamp nut, the clamp ring, the gland, one washer, the rubber packing, and the packing box, in that order.
- f. Insert the end of the cable into the terminal box.
- g. Tighten the gland to grip the cable.
When tightening the union cover, tighten approximately one turn past the point where the cable will no longer move up and down. Proper tightening is important. If it is too tight, a circuit break in the cable may occur; if not tight enough, the flameproof effectiveness will be compromised.



CAUTION

Tighten the gland approximately one turn after the point where you can no longer shift the cable up and down by hand.
Take great care in this step, since proper tightening is very important.

- h. Fasten the cable with tightening the clamp nut.
- i. Tighten the lock nut on the union cover.
- j. Connect the cable wires to each terminal.

Table 4.2 Type of Packing and Applicable Cable O.D.

Wiring port thread diameter	Appropriate cable outer diameter (mm)	Identifying mark	Part Number
G1/2	8-10	16 8-10	G9601AM
	10.1-12	16 10-12	
G3/4	10-12	22 10-12	G9601AN
	12.1-14	22 12-14	
	14.1-16	22 14-16	

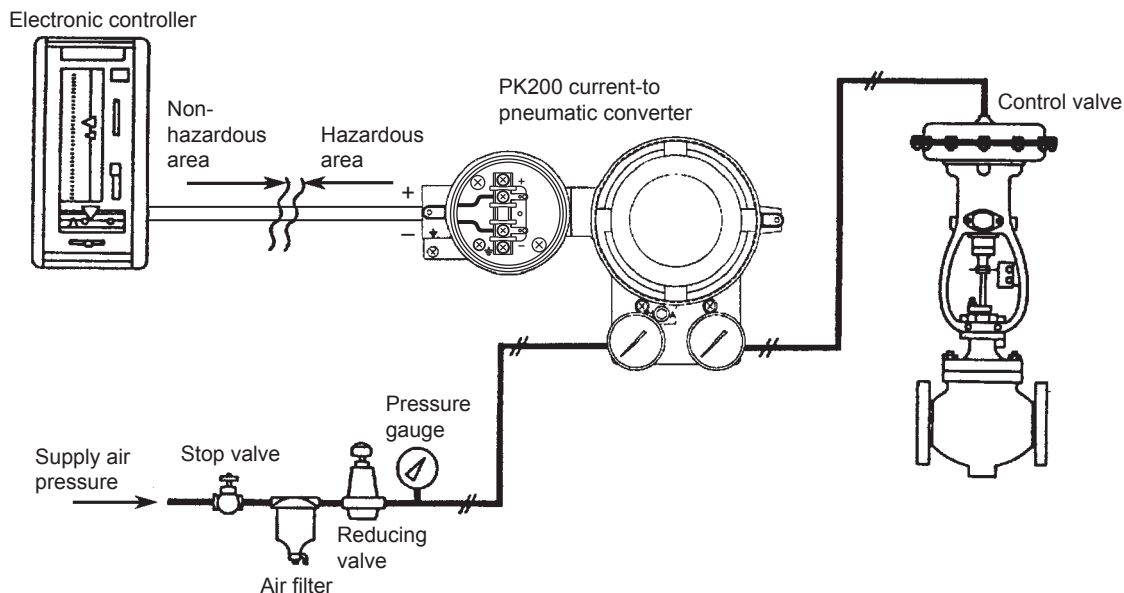

Figure 4.1 General-Use and Flameproof Type Wiring

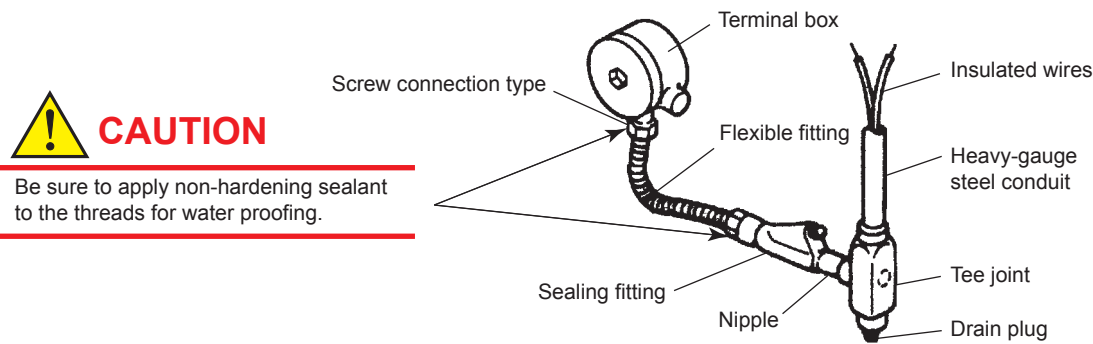

Figure 4.2 Flameproof Metal Conduit Wiring

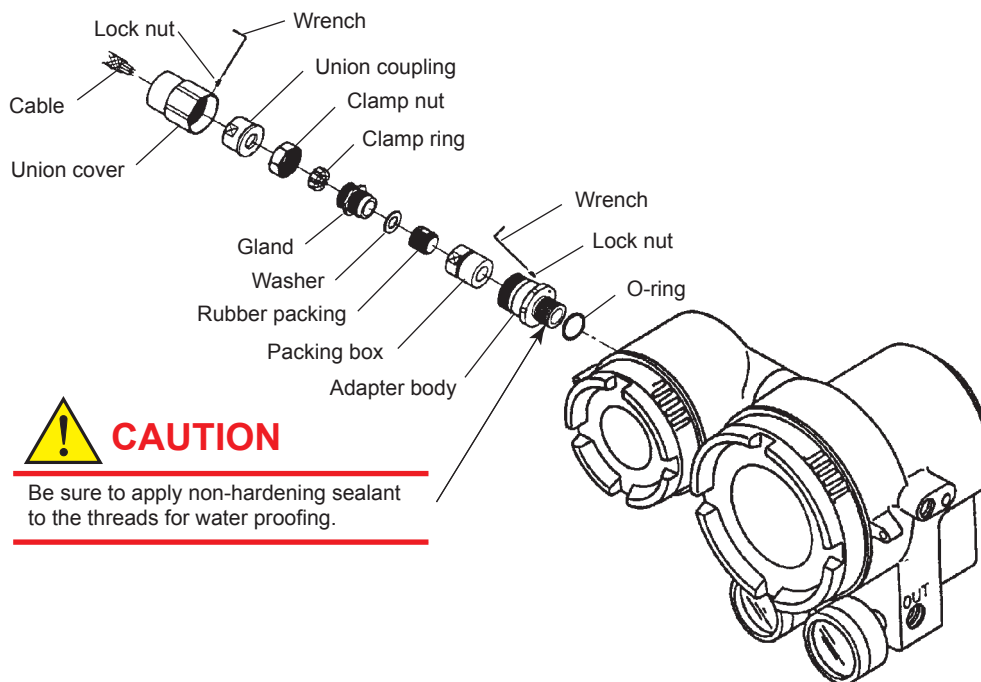

Figure 4.3 Flameproof Gland Packing Installation (Option code: /G11 and /G21)

4.2.3 Grounding

- (1) Provide grounding with a ground resistance of 100Ω.
- (2) Grounding terminals are provided inside and outside of the terminal box. Use either terminal.
- (3) Use 600V PVC insulated wire for grounding wiring.

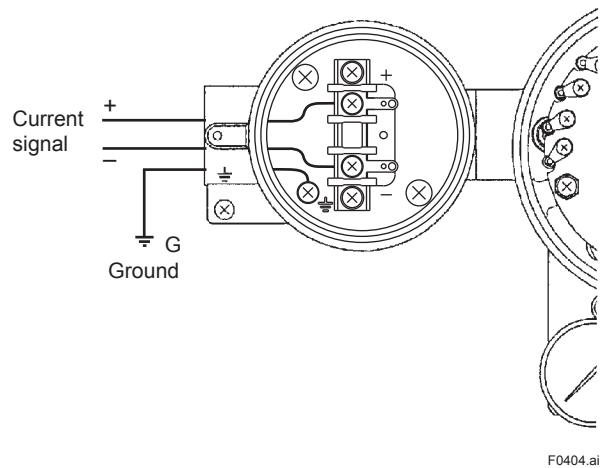

Figure 4.4 Wiring

4.3 Intrinsically Safe Type Wiring

The wiring of the intrinsically safe circuit between the converter and the safety barrier must be kept routed with sufficient physical separation from other circuits so as not to be affected by electromagnetic induction, etc., and should be implemented using metallic conduit or shielded cable.

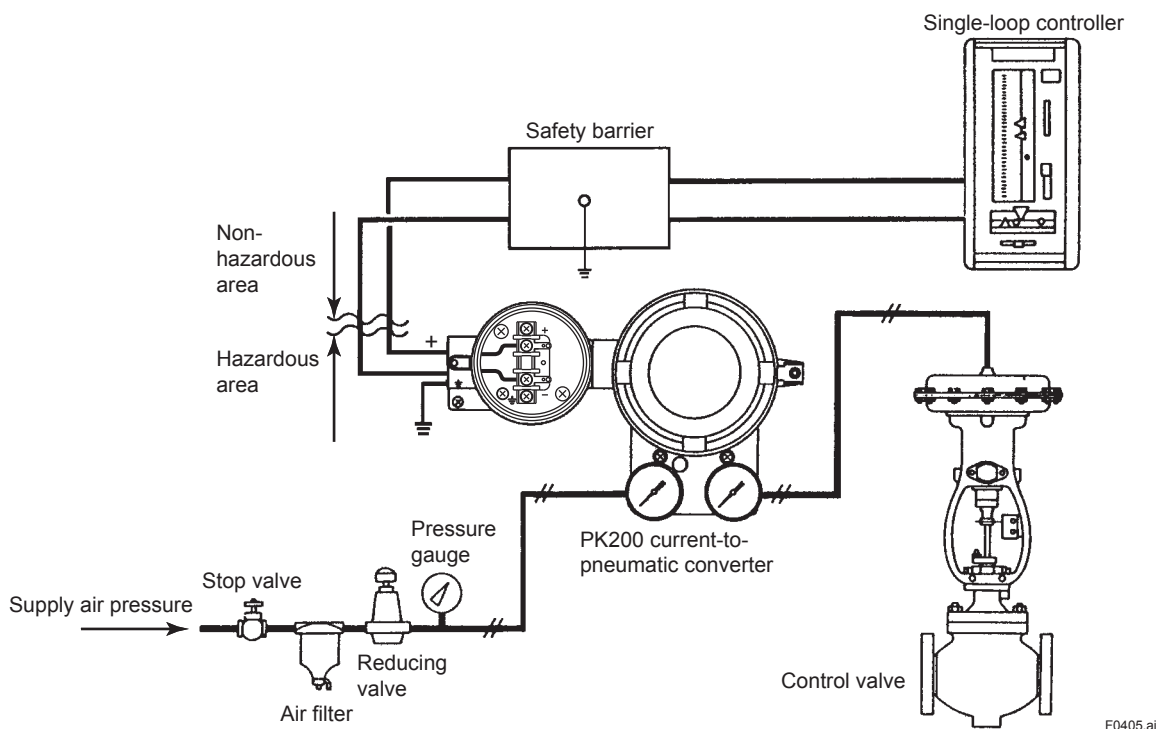

Figure 4.5 Intrinsically Safe Type Wiring

5. Operation

5.1 Auto/Manual (A/M) Transfer Mechanism

Please refer to following instruction for the model with A/M selector switch (optional code: /AM).

For the model without A/M selector switch, please go to section 5.2.

Use of A/M transfer mechanism requires that a supply pressure adjusting regulator be installed.

- (1) Set the A/M selector switch provided at the front (on the supply air pressure gauge side) of the converter to "M." (Turn the switch clockwise.)
- (2) This allows supply air pressure to be output, which is supplied to the regulator.
- (3) Output air pressure can be regulated using the pressure regulator. Because the output pressure is not same as supply pressure, it is necessary to adjust it watching an output pressure gauge attached to this instrument. Pressure gauge minimum unit is 10kPa (standard output type) or 20kPa (doubled output type).

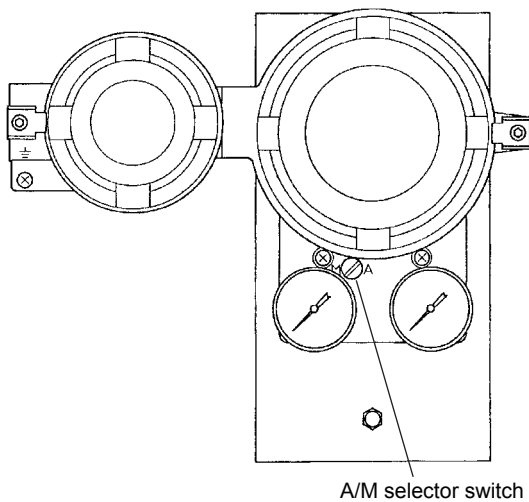

F0501.ai

Figure 5.1 Auto/Manual Transfer Mechanism

5.2 Zero Point Adjustment

- (1) For the model with A/M selector switch, please set the A/M selector switch to A (Auto). (Turn the switch counterclockwise.)
- (2) Apply supply air pressure to the current-to-pneumatic converter.
For supply air pressure, see the data plate or Table 5.1 "Recommended Supply Air Pressure." Standard output applies for model suffix output signal code "1, 3, 5, 7" and multiplied pressure output for model suffix output signal code "2, 4, 6, 8, 9."

Table 5.1 Recommended Supply Air Pressure

Output Signal Code	Output Signal	Supply Air Pressure
1	20 to 100 kPa	130 to 150 kPa
2	40 to 200 kPa	230 to 260 kPa
3	0.2 to 1.0 kgf/cm ²	1.3 to 1.5 kgf/cm ²
4	0.4 to 2.0 kgf/cm ²	2.3 to 2.6 kgf/cm ²
5	0.2 to 1.0 bar	1.3 to 1.5 bar
6	0.4 to 2.0 bar	2.3 to 2.6 bar
7	3 to 15 psi	19 to 22 psi
8	6 to 30 psi	34 to 37 psi
9	3 to 27 psi	34 to 36 psi

- (3) Then input an input signal.
Input a 0% electric signal.
Apply 4mA for 4 to 20mA input or 10mA for 10 to 50mA input.
- (4) Make zero point adjustment so that the output air pressure reaches the specified pressure. For output air pressure, see the data plate or Table 5.2 "Output Signals."
To increase output air pressure, turn the zero adjustment clockwise. To decrease the pressure, turn the zero adjustment counterclockwise. (See Figure 5.2.)
For the model with reverse action (/RA), please turn zero adjustment counterclockwise to increase output air pressure. To decrease output air pressure, please turn zero adjustment clockwise.

<Example: 20 to 100 kPa output signal for 4 to 20 mA input signal>

Adjust the zero adjustment so that an output signal of 20kPa is obtained when a 4mA input signal is applied.

Table 5.2 Output Signals

Output Signal Code	Output Signal
1	20 to 100 kPa
2	40 to 200 kPa
3	0.2 to 1.0 kgf/cm ²
4	0.4 to 2.0 kgf/cm ²
5	0.2 to 1.0 bar
6	0.4 to 2.0 bar
7	3 to 15 psi
8	6 to 30 psi
9	3 to 27 psi

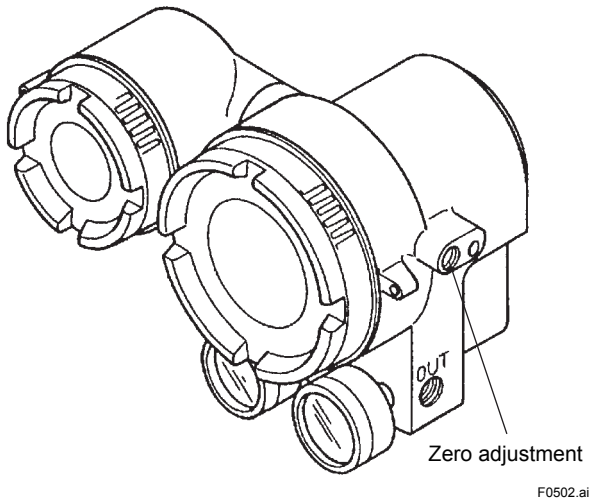

Figure 5.2 Zero Point Adjustment Mechanism

5.3 Calibration

CAUTION

Always perform calibration in a non-hazardous area.

- (1) For the model with A/M selector switch, please set the A/M selector switch to A (Auto). (Turn the switch counterclockwise.)
- (2) Remove the converter cover.

WARNING

For flameproof specifications or intrinsically safe explosion-proof specifications, first conduct a gas detector check to confirm that there is no explosive gas in the area.

- (3) Apply supply air pressure to the current-to-pneumatic converter.
For supply air pressure, see the data plate or Table 5.3 “Supply Air Pressure.”
Standard output applies for model suffix output signal code “1, 3, 5, 7” and multiplied pressure output for model suffix output signal code “2, 4, 6, 8, 9.”

Table 5.3 Recommended Supply Air Pressure

Output Signal Code	Output Signal	Supply Air Pressure
1	20 to 100 kPa	130 to 150 kPa
2	40 to 200 kPa	230 to 260 kPa
3	0.2 to 1.0 kgf/cm ²	1.3 to 1.5 kgf/cm ²
4	0.4 to 2.0 kgf/cm ²	2.3 to 2.6 kgf/cm ²
5	0.2 to 1.0 bar	1.3 to 1.5 bar
6	0.4 to 2.0 bar	2.3 to 2.6 bar
7	3 to 15 psi	19 to 22 psi
8	6 to 30 psi	34 to 37 psi
9	3 to 27 psi	34 to 36 psi

- (4) Then input a 0% input signal.
Apply 4 mA for 4 to 20mA input or 10mA for 10 to 50mA input.
Control the zero adjustment so that the output air pressure reaches the specified pressure.
For 0% output air pressure, see the data plate or Table 5.4 “Output Signals.”
To increase output air pressure, turn the zero adjustment clockwise. To decrease the pressure, turn the zero adjustment counterclockwise.
For the model with reverse action (/RA), please turn zero adjustment counterclockwise to increase output air pressure. To decrease output air pressure, please turn zero adjustment clockwise.

Table 5.4 Output Signals

Output Signal Code	Output Signal
1	20 to 100 kPa
2	40 to 200 kPa
3	0.2 to 1.0 kgf/cm ²
4	0.4 to 2.0 kgf/cm ²
5	0.2 to 1.0 bar
6	0.4 to 2.0 bar
7	3 to 15 psi
8	6 to 30 psi
9	3 to 27 psi

(5) Input a 100% input signal.
 Apply 20mA for 4 to 20mA input or 50mA for 10 to 50mA input.
 Control the zero adjustment so that the output air pressure reaches a specified pressure.
 For 100% output air pressure, see the data plate or Table 5.2 "Output Signals." (See Figure 5.3.)
 To increase output air pressure, please turn span adjustment clockwise. To decrease output air pressure, please turn span adjustment counterclockwise. (See Figure 5.3.)
 For the model with reverse action (/RA), please turn span adjustment counterclockwise to increase output air pressure. To decrease output pressure, please turn span adjustment clockwise.

(6) Input a 0% input signal.
 Confirm if 0% output air pressure reaches the specified pressure. If not, make zero point adjustment.
 (7) Input a 100% input signal
 Confirm if 100% output air pressure reaches the specified pressure. If not, make span adjustment.
 (8) Repeat steps (6) and (7) two to three times to adjust the zero point and span.
 (9) After completing adjustments, change the input signal to 0%, 25%, 50%, 75%, and 100% and confirm if the specified output is reached at the relevant input.
 Confirm the accuracy with reference to the input and output signal reference values given in Table 5.5 "Input and Output Signals."

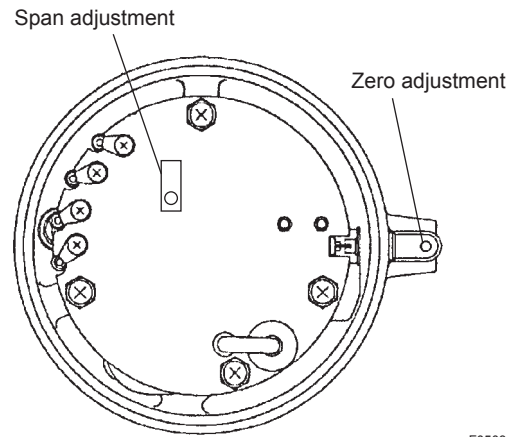

Figure 5.3 Span Adjustment Mechanism

Table 5.5 Input and Output Signals

Input Current of the model with / RA is shown in ().

Input	4 to 20mA	4mA (20mA)	8mA (16mA)	12mA (12mA)	16mA (8mA)	20mA (4mA)
	10 to 50mA	10mA (50mA)	20mA (40mA)	30mA (30mA)	40mA (20mA)	50mA (10mA)
Output Signal		0 %	25 %	50 %	75 %	100 %
Output Signal	1	20 kPa	40 kPa	60 kPa	80 kPa	100 kPa
	2	40 kPa	80 kPa	120 kPa	160 kPa	200 kPa
	3	0.2 kgf/cm ²	0.4 kgf/cm ²	0.6 kgf/cm ²	0.8 kgf/cm ²	1.0 kgf/cm ²
	4	0.4 kgf/cm ²	0.8 kgf/cm ²	1.2 kgf/cm ²	1.6 kgf/cm ²	2.0 kgf/cm ²
	5	0.2 bar	0.4 bar	0.6 bar	0.8 bar	1.0 bar
	6	0.4 bar	0.8 bar	1.2 bar	1.6 bar	2.0 bar
	7	3 psi	6 psi	9 psi	12 psi	15 psi
	8	6 psi	12 psi	18 psi	24 psi	30 psi
	9	3 psi	9 psi	15 psi	21 psi	27 psi

<Example: For 20 to 100 kPa output signal at 4 to 20 mA input signal>

Calibrate the input and output signals with reference to Table 5.6 Accuracy should be within ±0.5% of span.

Table 5.6 Input and Output Signals

	Input Signal	Output Signal
0%	4 mA	20 kPa
25%	8 mA	40 kPa
50%	12 mA	60 kPa
75%	16 mA	80 kPa
100%	20 mA	100 kPa

5.4 Range Adjustment

Perform the following to change to an output signal other than those specified in Table 5.4 "Output Signals."

Zero point adjustable range is ±10% of span and the span adjustable range is from 100 to 125%. An output signal can be flexibly regulated within these ranges using the zero and span adjustments.

Table 5.7 Zero and Span Adjustable Ranges

Output Signal Code	Zero Adjustable Range	Span Adjustable Range
1	12 to 28 kPa	80 to 100 kPa
2 *1	24 to 56 kPa	160 to 200 kPa
3	0.12 to 0.28 kgf/cm ²	0.8 to 1.0 kgf/cm ²
4 *2	0.24 to 0.56 kgf/cm ²	1.6 to 2.0 kgf/cm ²
5	0.12 to 0.28 bar	0.8 to 1.0 bar
6 *3	0.24 to 0.56 bar	1.6 to 2.0 bar
7	1.8 to 4.2 psi	12 to 15 psi
8 *4	3.6 to 8.4 psi	24 to 30 psi
9 *5	0.6 to 5.4 psi	24 to 30 psi

- *1: Please set the supply air pressure at the maximum working pressure plus 30 to 60kPa.
- *2: Please set the supply air pressure at the maximum working pressure plus 0.3 to 0.6kgf/cm².
- *3: Please set the supply air pressure at the maximum working pressure plus 0.3 to 0.6bar.
- *4: Please set the supply air pressure at the maximum working pressure plus 4 to 7psi.
- *5: Please set the supply air pressure at the maximum working pressure plus 7 to 9psi.

5.5 4 to 20mA/10 to 50mA Selection

Take the following steps to select an input signal by using 4 to 20mA/10 to 50mA selecting function. 4 to 20mA or 10 to 50mA can be selected by changing the SOCKET switch on the amplifier shown in Figure 5.4. (Input signal is calibrated at 4 to 20mA at the time of delivery.)

For 4 to 20mA input, insert the SOCKET switch to the two right pins. For 10 to 50mA input, insert the SOCKET switch to the two left pins.



NOTE

Before switching the SOCKET switch, always cut off the input signal.

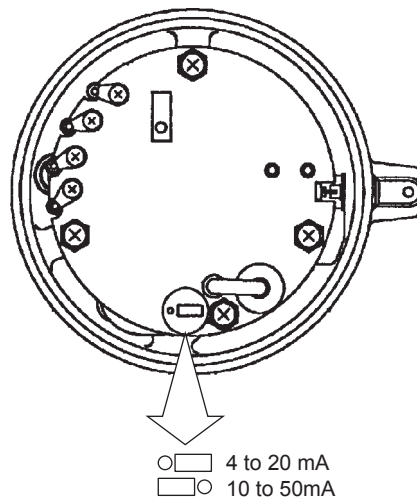

Figure 5.4 4 to 20mA/10 to 50mA Selection

F0504.ai

6. Maintenance

6.1 Overview

The PK200 converter components are structured as units to allow easy maintenance.

This chapter describes cleaning of each component and part replacement to be conducted for PK200 maintenance.

This converter is a high-precision instrument and thus, read the following description carefully before performing maintenance.

For maintenance, also see the operation items in Chapter 5.

CAUTION

Cautions for intrinsically safe apparatus
Intrinsically safe apparatus shall be repaired by the manufacturer.

Cautions for flameproof type instruments

- (a) Flameproof type instruments must be, as a rule, removed to a non-hazardous area for maintenance and be disassembled and reassembled to the original state. For details, see "Installation and Operating Precautions for TIIS Flameproof Equipment" later in this manual.
- (b) On the flameproof type instruments the cover is locked by a setscrew. When a setscrew is driven clockwise by an Allen wrench, it is going in and cover lock is released, and then the cover can be opened. When a cover is closed it should be locked by a setscrew without fail.

6.2 Periodic Inspection

Periodic inspection is required for maintaining normal plant operations. During periodic inspection, pay special attention to the following.

- (1) Is the appearance normal?
- (2) Is there pressure leakage from the converter or its peripheral piping?
- (3) Is drainage present, or is there adhesion of dust or oil, in the air supply system?

Periodically clean the restrictor and nozzle flapper, which are easily subject to contamination. The following describes their cleaning.

6.2.1 Cleaning the Restrictor

Remove the restrictor shown in Figure 6.1 using a screw driver and thread a wire with 0.3mm dia. into the restrictor for cleaning.

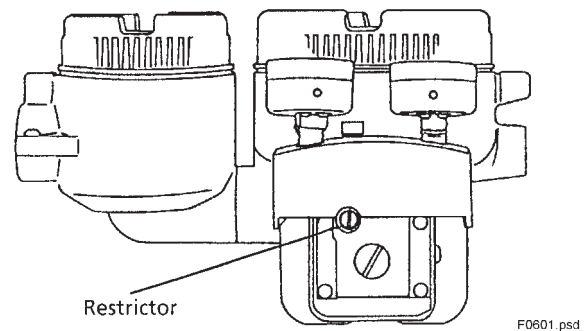

Figure 6.1 Restrictor Removal

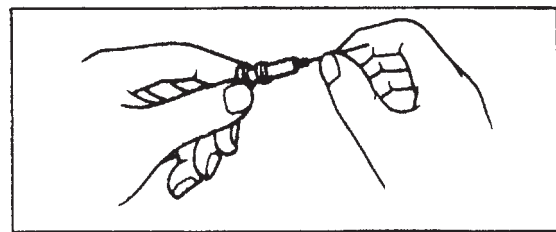

Figure 6.2 Cleaning the Restrictor

6.3 Parts Replacement

6.3.1 Replacing the Screen Filter

If the mesh filter located at the rear of the supply pressure connection and output air pressure connection is clogged, use a sharp-edged tool such as tweezers to remove the filter and replace it with a new one.

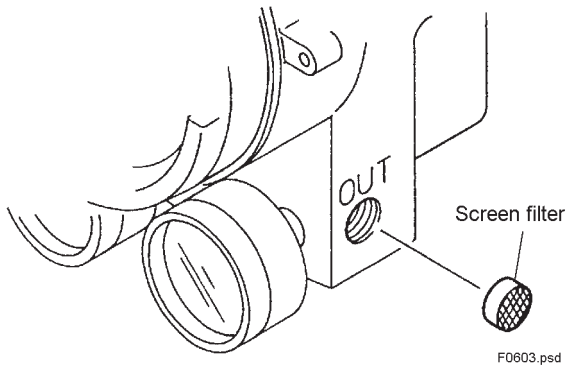

Figure 6.3 Removing the Screen Filter (OUT Side)

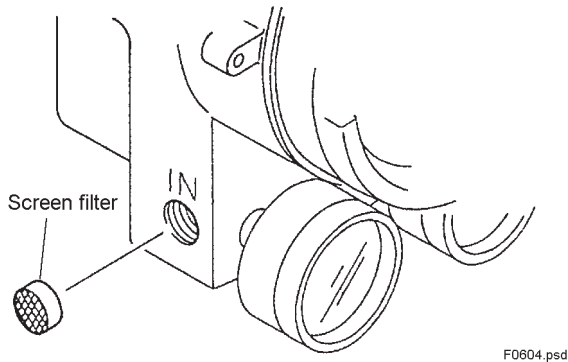

Figure 6.4 Removing the Screen Filter (IN Side)

6.3.2 Replacing the Controller Relay

- (1) Set the air supply pressure to zero.
- (2) Remove the controller relay from the bottom of the converter.
Unscrew the two mounting screws on the lower front face of the converter main body (see Figure 6.5) using a Phillips screwdriver. The relay can be removed downward.
- (3) When installing a new relay, attach the relay to the bottom of the converter, then fasten the relay using the two mounting screws at the front face of the converter.

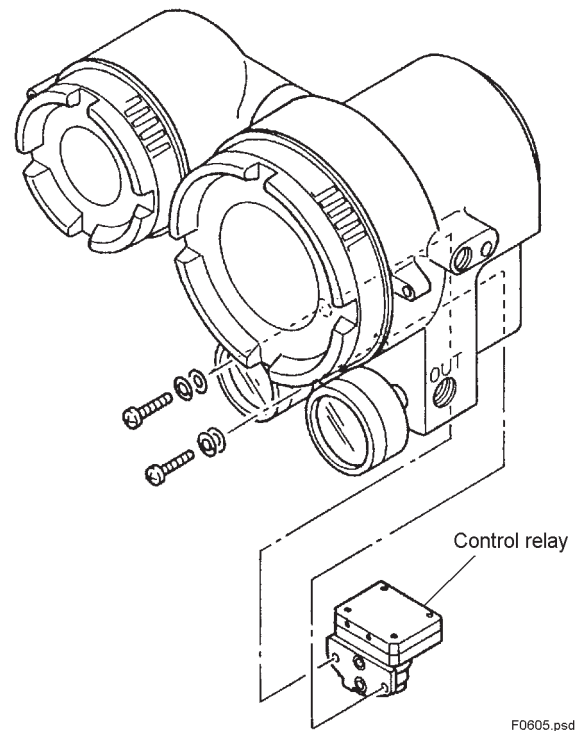

Figure 6.5 Removing the Control Relay

6.3.3 Replacing the Amplifier Assembly

An amplifier for replacement comes with a tube and four set screws.

■ Removing the Amplifier

- (1) Turn off the power and set the air supply pressure to zero.
- (2) Turn the amplifier cover counterclockwise to remove it.
- (3) Adjust the zero adjustment control to the position indicated in Figure 6.6.

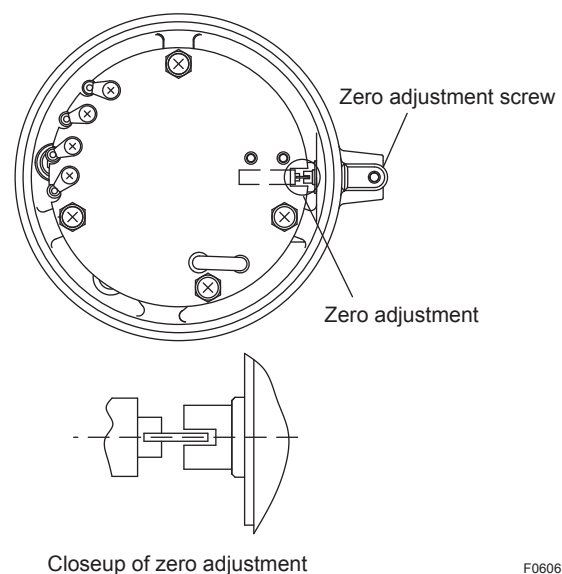

Figure 6.6 Zero Adjustment

- (4) Remove the silicon tube (a) from the pressure sensor on the amplifier.
- (5) Remove the four set screws (b) for fixing wires on the amplifier and then disconnect the wires.
- (6) Remove the four set screws (c) for fixing the amplifier.

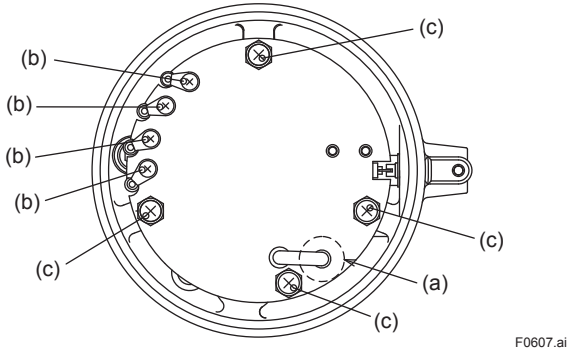

Figure 6.7 Pressure Sensor and Amplifier Set Screws

- (7) Pull out the amplifier directly, taking care not to bend the zero adjustment control.
- (8) Remove the silicon tube left in the case.

■ Mounting the Amplifier

- (1) Insert the accessory silicon tube into the body cap firmly.

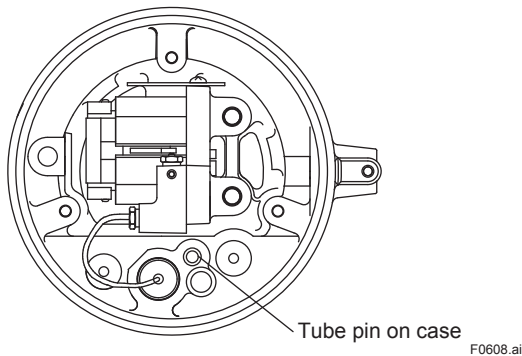

Figure 6.8 Silicon Tube Case Cap

CAUTION

Be sure to use the accessory silicon tube that comes with the amplifier for replacement. Note that the tube size varies depending on the amplifier to be used. Be sure to use the proper tube to prevent air leakage and precision deterioration.

- (2) Adjust the angle so that the volume knob of zero adjustment forms a right angle with the amplifier.

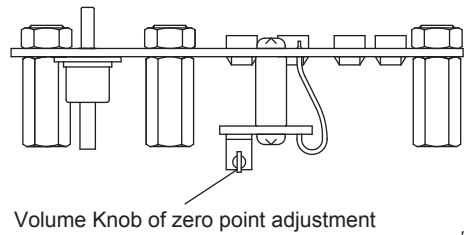

Figure 6.9 Zero Adjustment Control

- (3) Pass the silicon tube through an amplifier hole and mount the amplifier directly so that the sleeve of the pressure sensor leads into the hole of the case.



NOTE

- Do not apply undue pressure to the pressure sensor.
- Do not bend the zero adjustment volume knob to prevent it from contacting the zero adjustment set screw.

- (4) Fasten the four set screws for fixing the amplifier (see Figure 6.7).
- (5) Connect the four wires in the order of yellow (ACT+), white (ACT-), red (IN+) and black (IN-).
- (6) Insert the silicon tube into the amplifier pressure sensor firmly.

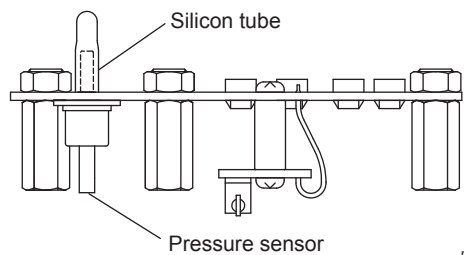

Figure 6.10 Pressure Sensor and Silicon Tube

- (7) In a model allowing 4-20/10-50mA selection, refer to 5.5 to set the socket switch as necessary.
- (8) Mount the amplifier cover.

■ Inspection after Amplifier Replacement

After replacing the amplifier, perform the insulation resistance test and withstand voltage test. Be sure to perform them according to the following procedure, referring to the corresponding tester instruction manuals.



CAUTION

- Overvoltage of the test voltage that is so small that it does not cause an dielectric breakdown may in fact deteriorate insulation and lower the safety performance; to prevent this it is recommended that the amount of testing be kept to a minimum.
- The voltage for the insulation resistance test must be 500V DC or lower, and the voltage for the withstand voltage test must be 500V AC or lower. Failure to heed these guidelines may cause faulty operation.
- Where a built-in arrester is provided (suffix code: /A), the voltage for the insulation resistance test must be 100V DC or lower, and the voltage for the withstand voltage test must be 100V AC or lower. Failure to heed these guidelines may cause faulty operation.

Follow the steps below to perform the test, the wiring of the communication line must be removed before initiating testing.

■ Insulation resistance test procedure

1. Lay transition wiring between the + terminal and the - terminal.
2. Connect the insulation resistance meter (with the power turned OFF) between the transition wiring of Step 1 above and ground terminal. The polarity of the input terminals must be positive and that of the ground must be negative.
3. Turn the power of the insulation resistance meter ON and measure the insulation resistance. The duration of the applied voltage must be the period during which 100 M Ω or more is confirmed (or 20 M Ω if the unit is equipped with a built-in arrester).
4. Upon completion of the test, remove the insulation resistance meter, connect a 100 k Ω resistor between the transition wiring, and allow the electricity to discharge. Do not touch the terminal with your bare hands while the electricity is discharging for more than one second.

■ Withstand voltage test procedure

Testing between the input terminals and the grounding terminal

1. Lay the transition wiring between the + terminal and the - terminal, and connect the withstand voltage tester (with the power turned OFF) between the transition wiring and the grounding terminal.
Connect the grounding side of the withstand voltage tester to the grounding terminal.
2. After setting the current limit value of the withstand voltage tester to 10 mA, turn the power ON, and gradually increase the impressed voltage from 0 V to the specified value.
3. The voltage at the specified value must remain for a duration of one minute.
4. Upon completion of the test, carefully reduce the voltage so that no voltage surge occurs.

7. Troubleshooting

7.1 Overview

If the PK200 converter does not operate normally, check the condition carefully and solve any problem in accordance with section 7.3 Troubleshooting Flow.

If problem appears difficult to correct, consult YOKOGAWA service personnel.

7.2 Operation Principle

The PK200 current-to-pneumatic converter accepts a 4 to 20mA or 10 to 50mA current signal from an electronic controller as an operating signal. This signal is input to a torque motor via an electric circuit, generating a torque proportional to the current signal.

An increase in the input signal causes the flapper at the end of the torque motor moving piece to move in the nozzle closing direction. When the nozzle is closed, back pressure increases, displacing the input diaphragm inside the control relay. This causes the control relay output air pressure to increase.

This output air pressure is output as PK200 converter output pressure and is also input to a feedback pressure sensor. The sensor then converts the pressure input into an electric signal, which is fed back to the electric circuit. The signal is then compared with the manipulated output signal, the result of which activates modification action until an output air pressure balanced with the input signal is obtained.

In this way, an output air pressure proportional to the input signal, which is a manipulated output signal, is obtained.

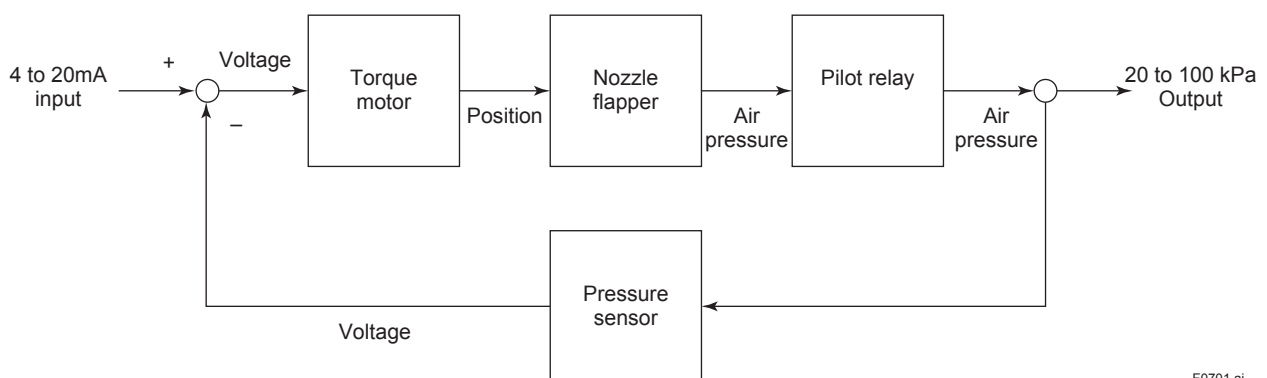

F0701.ai

Figure 7.1 PK200 Current-to-Pneumatic Converter Operation Principle Diagram

7.3 Troubleshooting Flow

The PK200 current-to-pneumatic converter causes relatively few problems as long as it is used correctly. However, inadequate preparation such as in mounting or service conditions may result in a problem.

If the converter does not operate normally, take correct measures by following the flow chart below. Some problems include a complex cause which may not be uncovered by the following flow chart. If a problem appears difficult to correct, contact our service personnel.

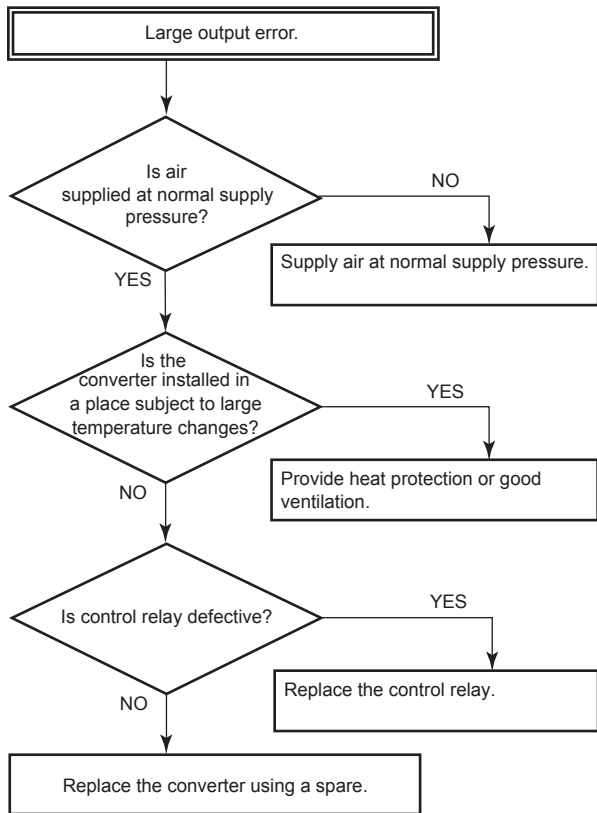

F0702.ai

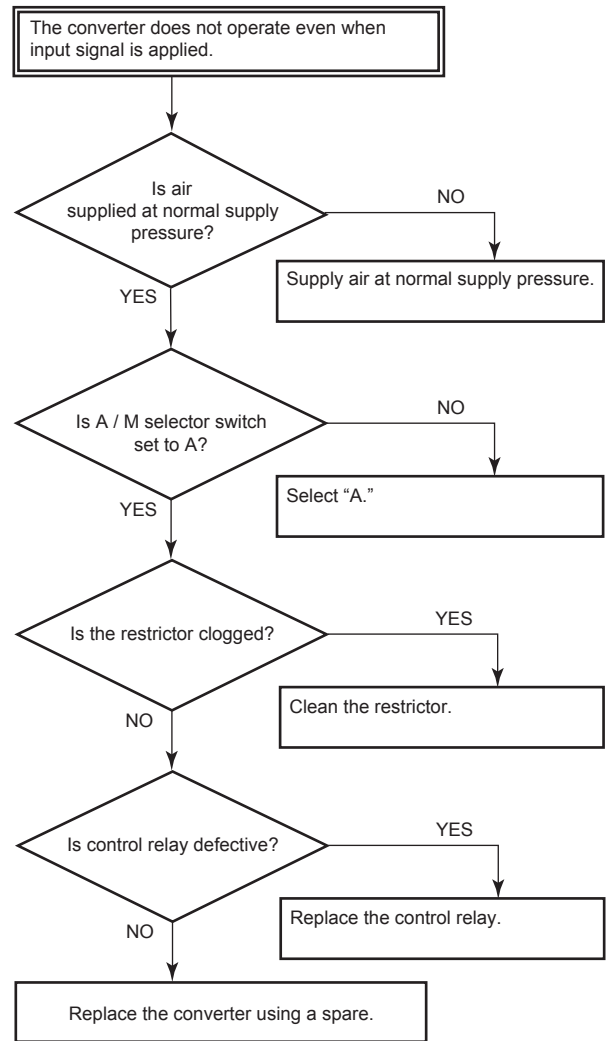

F0703.ai

Appendix A. Air Supply System

1. Overview

Pneumatic industrial instruments are one of the most maintenance-free, highly reliable industrial instrument systems and are in wide use. Such features are fully demonstrated only when suitable service conditions where the characteristics of pneumatic instruments are sufficiently taken into account are established.

One of such service conditions includes an air supply system. Pneumatic instruments require clean, dry air and thus, an aftercooler, filter, and air drier are installed after a compressor to prevent water, oil, and other contaminants from entering into the instruments. Also, care should be exercised as described below at service points.

2. Air Supply System

(1) Example of Panel-Mounting Instrument

When air is to be supplied to multiple instruments it is recommended that two reducing valves are used in parallel as shown in Figure A.1. Parallel arrangement protects instruments from interference even if one reducing valve is suspended due to clogging. Also, use of a three-way cock as shown in Figure A.1 allows any of air supply systems to be separated for maintenance. Generally, both air supply systems are used in parallel for operation. To supply clean and dry air to instruments, considerations should be made, such as provision of water drain, filter, and downward pitch (1/100 or more) for piping.

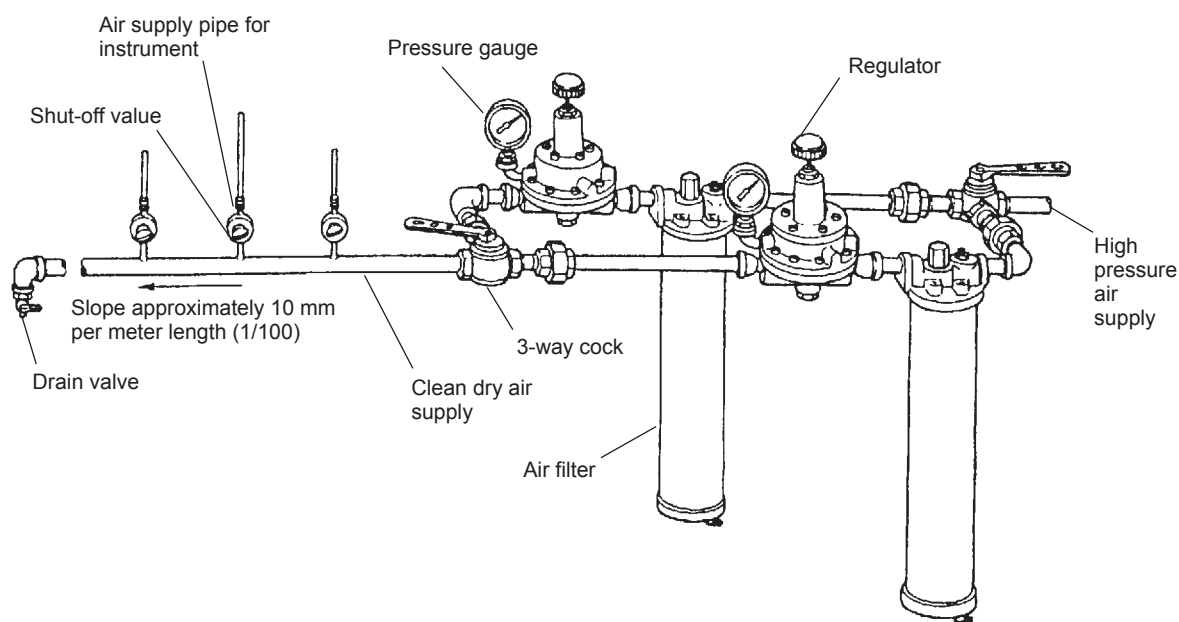

F0A01.ai

Figure A.1 Example of Air Supply System (for Panel-Mounting Instrument)

(2) Example for Field-Mounting Instruments

Figure A.2 shows an air-supply system for service point with respect to field-mounting instruments (individually installed instruments).

Securely install a filter and reducing valve in air supply piping that is nearest to an instrument. (These devices are not required if the instrument has a filter and reducing valve.)

Also, it is recommended that a shut-off valve be installed in the air supply pipe to allow removal of individual instruments without cutting off the entire air supply system.

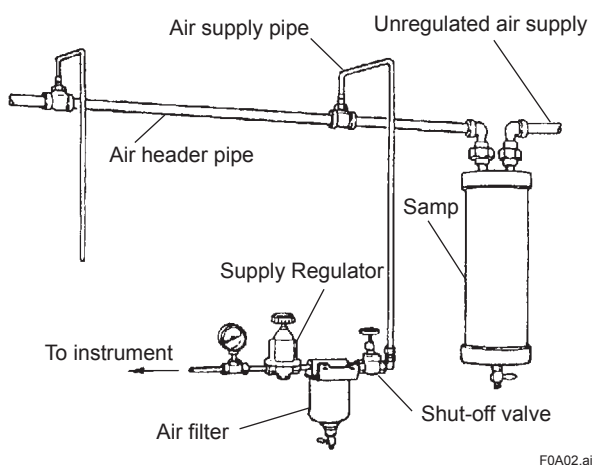

Figure A.2 Example of Air Supply System (for Field-Mounting Instruments)

(3) Air supply System for Field-Mounted Instruments

- **Supply Air**
Clean, dry air is required. An aftercooler, filter, air drier are used to eliminate water, oil, and other contaminants.
- **Air Supply Header (Air Header)**
The air header that supplies air to a series of instruments is installed with a minimum downward pitch of 10 mm/m (1/100) so that moisture and oil entrapped in the header can be discharged.
- **Air Supply Piping**
An air supply pipe connected to an instrument is branched from the upper part of an air header to prevent moisture entry. Even if this is not possible, an air supply pipe should be branched from the side of the air header, i.e., it must not be branched from the bottom part of the header. It is recommended that an air supply pipe be provided with a shut-off valve so that individual instruments can be removed.
- **Air Filter**
A filter removes moisture, oil, and other contaminants that cannot be removed by the main air supply system. In general a cock installed at the bottom of a filter is opened to discharge moisture, oil, and other contaminants. If the amount of moisture and oil is large, increase the number of draining times.

The above-noted methods and units are an example and there are other various methods and units. Use a method and units suitable for the process type to supply clean, dry air to instruments.

Installation and Operating Precautions for TIIS Intrinsically Safe Equipment

Apparatus Certified Under Technical Criteria (IEC-compatible Standards) and from “RECOMMENDED PRACTICES for Explosion-Protected Electrical Installations in General Industries,” published in 1979

1. General

The following describes precautions on electrical apparatus of intrinsically safe construction (hereinafter referred to as intrinsically safe apparatus).

Following the Labor Safety and Health Laws of Japan, an intrinsically safe apparatus must undergo type tests in order to be certified by the Technical Institute of Industrial Safety, Inc. These tests are required to satisfy either the technical criteria for electrical machinery and equipment in compliance with explosionproof standards involving inflammable gases or vapors and for machinery and equipment having explosionproof performance (standards notification no. 556 from the Japanese Ministry of Labor) (hereinafter referred to as technical criteria), in conformity with IEC Standards, or the “Recommended Practice for Explosion-Protected Electrical Installations in General Industries,” published in 1979. Such a certified apparatus can be used in hazardous locations where inflammable gases or vapors may be present.

Certified apparatus includes a certification label and an equipment nameplate with the specifications necessary for explosion requirements as well as precautions on explosion protection. Please confirm these precautionary items and use them to meet specification requirements.

For electrical wiring and maintenance servicing, please refer to “Internal Wiring Rules” in the Electrical Installation Technical Standards as well as “USER’S GUIDELINES for Electrical Installations for Explosive Gas Atmospheres in General Industry,” published in 1994.

To meet intrinsically safe requirements, equipment that can be termed an “intrinsically safe apparatus” must:

- (1) be certified by the Technical Institute of Industrial Safety, Inc. in accordance with the Labor Safety and Health Laws of Japan and have the appropriate mark of certification labeled on its case, and
- (2) be used in compliance with the specifications marked on its certification label, equipment nameplate and precautionary information furnished.

Note: Intrinsically safe apparatus satisfy their performance under specific conditions. They are not always absolutely safe under every operational and environmental condition. In other words, they are not safe products involved with factors such as chemical reactions, geographical changes or the like other than affected by electric energy from the equipment itself.

2. Electrical Apparatus of Intrinsic Safety Type of Explosion-Protected Construction

The intrinsic safety type of explosion-protected construction is a method of protection applicable to a circuit or part of a circuit in which, under prescribed test conditions, no spark or thermal effect, whether produced normally or accidentally, is capable of causing a prescribed explosive gas to ignite. In other words, electrical apparatus of this construction is intended to suppress electrical energy thereby preventing ignition of a given explosive gas atmosphere even though spark or high thermal effect occurs in the electric circuitry.

Intrinsically safe electrical apparatus generally comprise intrinsically safe apparatus installed in a hazardous location and a safety barrier (associated apparatus), installed in a non-hazardous location, aimed at preventing electrical energy from flowing into the electric circuitry of intrinsically safe apparatus.

However, battery-operated, portable intrinsically safe apparatus or the like may be used alone.

3. Terminology

- (1) Intrinsically safe apparatus: Electrical apparatus in which all the circuits are intrinsically safe circuits.
- (2) Associated apparatus: Electrical apparatus in which there are both intrinsically safe circuits and non-intrinsically safe circuits that can affect the safety of intrinsically safe circuits.
- (3) Safety barrier: A specific type of associated apparatus, which consists mainly of safety barrier elements, and serves to limit the flow of excessive electrical energy, which is capable of causing ignition of a given explosive gas or vapour of a non-intrinsically safe circuit into concerned intrinsically safe circuits.
- (4) Apparatus of category “ia”: Intrinsically safe electrical apparatus and associated apparatus which are incapable of causing ignition of a given explosive gas or vapour with the appropriate safety factors such as:
 - when up to two countable faults are applied and, in addition,
 - when non-countable faults produce an onerous condition.
- (5) Apparatus of category “ib”: Intrinsically safe electrical apparatus and associated apparatus which are incapable of causing ignition of a given explosive gas or vapour, with the appropriate safety factors such as:
 - when up to one countable fault is applied and, in addition,
 - when non-countable faults produce an onerous condition.
- (6) Safety rating: A rating to be designated to intrinsically safe apparatus as well as associated apparatus and is the maximum rating allowable for maintaining intrinsic safety of concerned intrinsically safe circuits.

4. Caution on Combining Intrinsically Safe Apparatus and Safety Barriers

- (1) A combination of certified intrinsically safe apparatus and safety barriers needs to satisfy combination requirements. If intrinsically safe apparatus specify safety barriers for combination, safety barriers other than specified cannot be used (see Note 1 for more details).
- (2) Certified intrinsically safe systems specify specific safety barriers in combination with intrinsically safe apparatus. So safety barriers other than specified cannot be used (see Note 2 for more details).
- (3) Other than limitations of combining intrinsically safe apparatus and safety barriers as given in (1) and (2) above, two or more pieces of apparatus certified under different standards cannot be combined with each other (see Note 3 for more details). In addition, bear in mind that classifications of explosion protection such as “IIA,” “IIB” and “IIC” and category “ia” and “ib” limit a combination of intrinsically safe apparatus and safety barriers.

For more details, see the “Type Certificate Guide for Explosion-Protected Construction for Electrical Machinery and Equipment,” issued by the Japanese Ministry of Labour, the Research Institute of Industrial Safety.

Note 1: Testing Apparatus

Intrinsically safe apparatus and safety barriers are assessed individually to ensure that their safety requirements are satisfied. Tested and certified intrinsically safe apparatus and safety barriers incorporate individual certification numbers. A combination of intrinsically safe apparatus and safety barriers involves the following two limitations:

- (1) A safety barrier which meets the combination requirements by referring to its safety rating and combination parameters shall be selected.
- (2) For pressure transmitters, pH transmitters, temperature detectors and the like, safety barriers that can be combined are already specified. Other safety barriers cannot be used.

Note 2: Testing Intrinsically Safe System

An assembly (as a system) in which intrinsically safe apparatus and safety barriers are combined is assessed to ensure that its safety requirements are satisfied. A tested and certified system incorporates a certification number (intrinsically safe apparatus and safety barriers have the same certification number).

Note 3: Impossible Combinations of Apparatus Certified Under Different Standards

Intrinsically safe apparatus certified under technical criteria and safety barriers certified under the "Recommended Practice for Explosion-Protected Electrical Installations in General Industries" (1979) and vice versa cannot be combined even if their combination requirements are satisfied.

5. Installation of Intrinsically Safe Apparatus and Safety Barriers

(1) Classification of installation location

Intrinsically safe apparatus may be installed, depending upon applicable gases, in a hazardous area in Zone 0, 1 or 2 (Note 4 below), where the specified gases are present. However, note that apparatus certified under Technical Criteria, in category "ib" shall be installed only in Zone 1 or 2. Safety barriers (associated apparatus) that are combined with these intrinsically safe apparatus shall be installed only in a non-hazardous area. In cases where safety barriers are installed in a hazardous area, they shall be enclosed, for example, in a flameproof enclosure.

Note 4: Hazardous areas are classified in zones based upon the frequency of the appearance and the duration of an explosive gas atmosphere as follows:

- Zone 0: An area in which an explosive gas atmosphere is present continuously or is present for long periods.
- Zone 1: An area in which an explosive gas atmosphere is likely to occur in normal operation.
- Zone 2: An area in which an explosive gas atmosphere is not likely to occur in normal operation and if it does occur it will exist for a short period only.

(2) Ambient temperature limits for intrinsically safe apparatus

Intrinsically safe apparatus shall be installed in a location where the ambient temperature ranges from -20° to +40°C (for those certified under Technical Criteria) or -10° to +40°C (for those certified under the "Recommended Practice for Explosion-Protected Electrical Installations in General Industries" (1979)). However, some field-mounted intrinsically safe apparatus may be used at an ambient temperature up to 60°C. So, specifications should be checked before installing intrinsically safe apparatus.

If the intrinsically safe apparatus are exposed to direct sunshine or radiant heat from plant facilities, appropriate thermal protection measures shall be taken.

6. Wiring for Intrinsically Safe Circuits

In intrinsically safe construction, safety shall be maintained as an intrinsically safe system involving intrinsically safe apparatus and safety barriers connected thereto, and electrical wiring (through intrinsically safe circuits) interconnected between them. In other words, even when safety requirements are maintained individually by intrinsically safe apparatus and safety barriers, they shall not be affected by electrical or magnetic energy caused by electrical wiring.

To make electrical wiring for intrinsically safe circuits, you must:

- (a) refer to the equipment configuration diagram and make electrical wiring properly;
- (b) prevent intrinsically safe wiring from being contacted with non-intrinsically safe wiring, and separate the intrinsically safe circuit from other electrical circuits;
- (c) prevent intrinsically safe wiring from being electrostatically and magnetically affected by non-intrinsically safe wiring;
- (d) reduce wiring inductance and capacitance produced between the intrinsically safe apparatus and safety barrier where possible, and use a shorter cable between the intrinsically safe apparatus and safety barrier than specified if the maximum permissible inductance of the cable is specified as operating conditions;
- (e) conform to conditions of installation such as wiring method, earthing or the like, if any; and
- (f) protect the outer sheath of cables from damage with appropriate measures.

7. Maintenance and Inspection of Intrinsically Safe Apparatus and Safety Barriers

Maintenance and inspection of intrinsically safe apparatus and safety barriers shall be limited to within the instructions described in applicable instruction manuals. If other than this is required, contact the manufacturers. For more information, refer to the "USER'S GUIDELINES for Electrical Installations for Explosive Gas Atmospheres in General Industry" issued in 1994 by the Japanese Ministry of Labour, the Research Institute of Industrial Safety.

(1) Requirements for maintenance personnel

Maintenance and inspection of intrinsically safe apparatus and safety barriers shall be conducted by maintenance personnel skilled in intrinsically safe construction and installation of electrical devices as well as capable of applying associated rules.

(2) Maintenance and Inspection

- (a) Visual inspection
Visually inspect the external connections of intrinsically safe apparatus and safety barriers, and cables for damage or corrosion as well as other mechanical and structural defects.
- (b) Adjustments
Zero, span and sensitivity adjustments shall be made with applicable adjusting potentiometers and mechanical adjustment screws. These maintenance adjustments shall be made in a non-hazardous location.



CAUTION

If intrinsically safe apparatus and safety barriers require maintenance service and checking, a gas detector shall be used to ensure that there is no explosive gas in the location (maintenance servicing shall be conducted in a non-hazardous location).

(3) Repair

Intrinsically safe apparatus and safety barriers shall be repaired by manufacturers.

(4) Prohibition of modifications and specification changes

Do not attempt to make modifications or change specifications which may affect safety.

Installation and Operating Precautions for TIS Flameproof Equipment

Apparatus Certified Under Technical Criteria (IEC-compatible Standards)

1. General

The following describes precautions on electrical apparatus of flameproof construction (hereinafter referred to as flameproof apparatus) in explosion-protected apparatus.

Following the Labour Safety and Health Laws of Japan, flameproof apparatus is subjected to type tests to meet either the technical criteria for explosionproof electrical machinery and equipment (standards notification no. 556 from the Japanese Ministry of Labour) (hereinafter referred to as technical criteria), in conformity with the IEC Standards, or the "Recommended Practice for Explosion-Protected Electrical Installations in General Industries," published in 1979. These certified apparatus can be used in hazardous locations where explosive or inflammable gases or vapours may be present.

Certified apparatus includes a certification label and an equipment nameplate with the specifications necessary for explosion requirements as well as precautions on explosion protection. Please confirm these precautionary items and use them to meet specification requirements.

For electrical wiring and maintenance servicing, please refer to "Internal Wiring Rules" in the Electrical Installation Technical Standards as well as "USER'S GUIDELINES for Electrical Installations for Explosive Gas Atmospheres in General Industry," published in 1994.

To meet flameproof requirements, equipment that can be termed "flameproof" must:

- (1) Be certified by a Japanese public authority in accordance with the Labour Safety and Health Laws of Japan and have a certification label in an appropriate location on its case, and
- (2) Be used in compliance with the specifications marked on its certification label, equipment nameplate and precautionary information furnished.

2. Electrical Apparatus of Flameproof Type of Explosion-Protected Construction

Electrical apparatus which is of flameproof construction is subjected to a type test and certified by the Japanese Ministry of Labour aiming at preventing explosion caused by electrical apparatus in a factory or any location where inflammable gases or vapours may be present. The flameproof construction is of completely enclosed type and its enclosure shall endure explosive pressures in cases where explosive gases or vapours entering the enclosure cause explosion. In addition, the enclosure construction shall be such that flame caused by explosion does not ignite gases or vapours outside the enclosure.

In this manual, the word "flameproof" is applied to the flameproof equipment combined with the types of protection "e", "o", "i", and "d" as well as flameproof equipment.

3. Terminology

(1) Enclosure

An outer shell of an electrical apparatus, which encloses live parts and thus is needed to configure explosion-protected construction.

(2) Shroud

A component part which is so designed that the fastening of joint surfaces cannot be loosened unless a special tool is used.

(3) Enclosure internal volume

This is indicated by:— the total internal volume of the flameproof enclosure minus the volume of the internal components essential to equipment functions.

(4) Path length of joint surface

On a joint surface, the length of the shortest path through which flame flows from the inside to outside of the flameproof enclosure. This definition cannot be applied to threaded joints.

(5) Gaps between joint surfaces

The physical distance between two mating surfaces, or differences in diameters if the mating surfaces are cylindrical.

Note: The permissible sizes of gaps between joint surfaces, the path length of a joint surface and the number of joint threads are determined by such factors as the enclosure's internal volume, joint and mating surface construction, and the explosion classification of the specified gases and vapours.

4. Installation of Flameproof Apparatus

(1) Installation Area

Flameproof apparatus may be installed, in accordance with applicable gases, in a hazardous area in Zone 1 or 2, where the specified gases are present. Those apparatus shall not be installed in a hazardous area in Zone 0.

Note: Hazardous areas are classified in zones based upon the frequency of the appearance and the duration of an explosive gas atmosphere as follows:

- Zone 0: An area in which an explosive gas atmosphere is present continuously or is present for long periods.
- Zone 1: An area in which an explosive gas atmosphere is likely to occur in normal operation.
- Zone 2: An area in which an explosive gas atmosphere is not likely to occur in normal operation and if it does occur it will exist for a short period only.

(2) Environmental Conditions

The standard environmental condition for the installation of flameproof apparatus is limited to an ambient temperature range from -20°C to $+40^{\circ}\text{C}$ (for products certified under Technical Criteria). However, some field-mounted instruments may be certified at an ambient temperature up to $+60^{\circ}\text{C}$ as indicated on the instrument nameplates. If the flameproof apparatus are exposed to direct sunshine or radiant heat from plant facilities, appropriate thermal protection measures shall be taken.

5. External Wiring for Flameproof Apparatus

Flameproof apparatus require cable wiring or flameproof metal conduits for their electrical connections. For cable wiring, cable glands (cable entry devices for flameproof type) to wiring connections shall be attached. For metal conduits, attach sealing fittings as close to wiring connections as possible and completely seal the apparatus. All non-live metal parts such as the enclosure shall be securely grounded.

For details, see the "USER'S GUIDELINES for Electrical Installations for Explosive Gas Atmospheres in General Industry," published in 1994.

(1) Cable Wiring

- For cable wiring, cable glands (cable entry devices for flameproof type) specified or supplied with the apparatus shall be directly attached to the wiring connections to complete sealing of the apparatus.
- Screws that connect cable glands to the apparatus are those for G-type parallel pipe threads (JIS B 0202) with no sealing property. To protect the apparatus from corrosive gases or moisture, apply non-hardening sealant such as liquid gaskets to those threads for waterproofing.

- Specific cables shall be used as recommended by the "USER'S GUIDELINES for Electrical Installations for Explosive Gas Atmospheres in General Industry," published in 1994.
- In necessary, appropriate protective pipes (conduit or flexible pipes), ducts or trays shall be used for preventing the cable run (outside the cable glands) from damage.
- To prevent explosive atmosphere from being propagated from Zone 1 or 2 hazardous location to any different location or non-hazardous location through the protective pipe or duct, apply sealing of the protective pipes in the vicinity of individual boundaries, or fill the ducts with sand appropriately.
- When branch connections of cables, or cable connections with insulated cables inside the conduit pipes are made, a flameproof or increased-safety connection box shall be used. In this case, flameproof or increased-safety cable glands meeting the type of connection box must be used for cable connections to the box.

(2) Flameproof Metal Conduit Wiring

- For the flameproof metal conduit wiring or insulated wires shall be used as recommended by the USER'S GUIDELINES for Electrical Installations for Explosive Gas Atmospheres in General Industry, published in 1994.
- For conduit pipes, heavy-gauge steel conduits conforming to JIS C 8305 Standard shall be used.
- Flameproof sealing fittings shall be used in the vicinity of the wiring connections, and those fittings shall be filled with sealing compounds to complete sealing of the apparatus. In addition, to prevent explosive gases, moisture, or flame caused by explosion from being propagated through the conduit, always provide sealing fittings to complete sealing of the conduit in the following locations:
 - (a) In the boundaries between the hazardous and non-hazardous locations.
 - (b) In the boundaries where there is a different classification of hazardous location.
- For the connections of the apparatus with a conduit pipe or its associated accessories, G-type parallel pipe threads (JIS B 0202) shall be used to provide a minimum of five-thread engagement to complete tightness. In addition, since these parallel threads do not have sealing property, non-hardening sealant such as liquid gaskets shall thus be applied to those threads for ensuring waterproofness.
- If metal conduits need flexibility, use flameproof flexible fittings.

6. Maintenance of Flameproof Apparatus

To maintain the flameproof apparatus, do the following. (For details, see Chapter 10 "MAINTENANCE OF EXPLOSION-PROTECTED ELECTRICAL INSTALLATION" in the USER'S GUIDELINES for Electrical Installations for Explosive Gas Atmospheres in General Industry.)

(1) Maintenance servicing with the power on.

Flameproof apparatus shall not be maintenance-serviced with its power turned on. However, in cases where maintenance servicing is to be conducted with the power turned on, with the equipment cover removed, always use a gas detector to check that there is no explosive gas in that location. If it cannot be checked whether an explosive gas is present or not, maintenance servicing shall be limited to the following two items:

- (a) Visual inspection
Visually inspect the flameproof apparatus, metal conduits, and cables for damage or corrosion, and other mechanical and structural defects.
- (b) Zero and span adjustments
These adjustments should be made only to the extent that they can be conducted from the outside without opening the equipment cover. In doing this, great care must be taken not to cause mechanical sparks with tools.

(2) Repair

If the flameproof apparatus requires repair, turn off the power and transport it to a safety (non-hazardous) location. Observe the following points before attempting to repair the apparatus.

- (a) Make only such electrical and mechanical repairs as will restore the apparatus to its original condition. For the flameproof apparatus, the gaps and path lengths of joints and mating surfaces, and mechanical strength of enclosures are critical factors in explosion protection. Exercise great care not to damage the joints or shock the enclosure.
- (b) If any damage occurs in threads, joints or mating surfaces, inspection windows, connections between the transmitter and terminal box, shrouds or clamps, or external wiring connections which are essential in flameproofness, contact Yokogawa Electric Corporation.



CAUTION

Do not attempt to re-process threaded connections or refinish joints or mating surfaces.

- (c) Unless otherwise specified, the electrical circuitry and internal mechanisms may be repaired by component replacement, as this will not directly affect the requirements for flameproof apparatus (however, bear in mind that the apparatus must always be restored to its original condition). If you attempt to repair the flameproof apparatus, company-specified components shall be used.
- (d) Before starting to service the apparatus, be sure to check all parts necessary for retaining the requirements for flameproof apparatus. For this, check that all screws, bolts, nuts, and threaded connections have properly been tightened.

(3) Prohibition of specification changes and modifications

Do not attempt to change specifications or make modifications involving addition of or changes in external wiring connections.

7. Selection of Cable Entry Devices for Flameproof Type



IMPORTANT

The cable glands (cable entry devices for flameproof type) conforming to IEC Standards are certified in combination with the flameproof apparatus. So, Yokogawa-specified cable entry devices for flameproof type shall be used to meet this demand.

References:

- (1) Type Certificate Guide for Explosion-Protected Construction Electrical Machinery and Equipment (relating to Technical Standards Conforming to International Standards), issued by the Technical Institution of Industrial Safety, Japan
- (2) USER'S GUIDELINES for Electrical Installations for Explosive Gas Atmospheres in General Industry (1994), issued by the Japanese Ministry of Labour, the Research Institute of Industrial Safety.

Customer Maintenance Parts List

Model PK200
Current-to-Pneumatic Converter

PK200

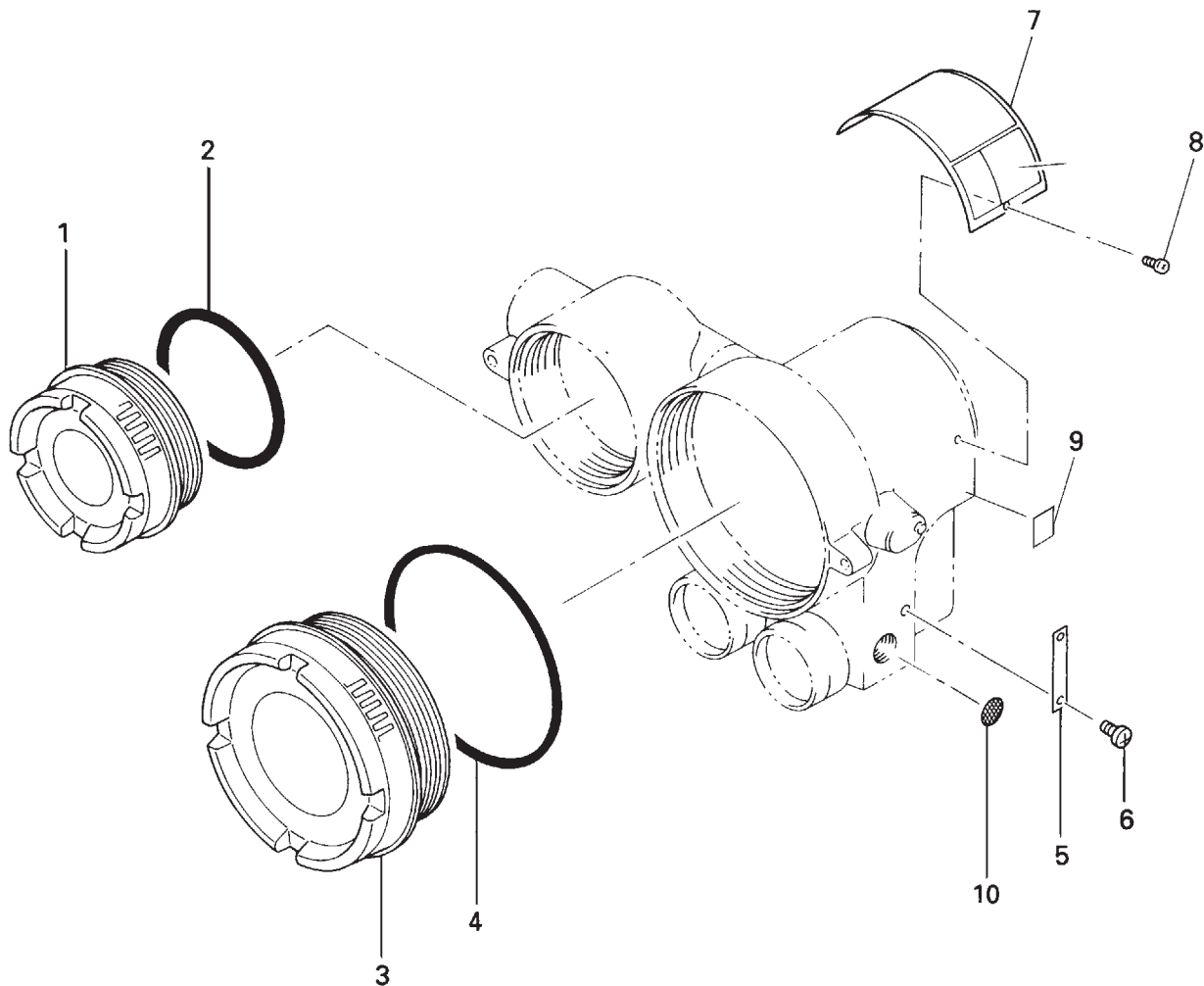

Item	Part No.	Qty	Description
1	F9172BS	1	Cover
2	Y9210XA	1	O-Ring
3	F9174VA	1	Cover
4	G9303LK	1	O-Ring
5	F9515AZ	1	Tag Plate
6	F9270SA	2	Self-tapping Screw
7	—	1	Nameplate (Dataplate)
8	F9270SA	2	Self-tapping Screw
9	—	1	Nameplate (for TIIS Flameproof option code: /JF3)
10	U0103FP	2	Screen

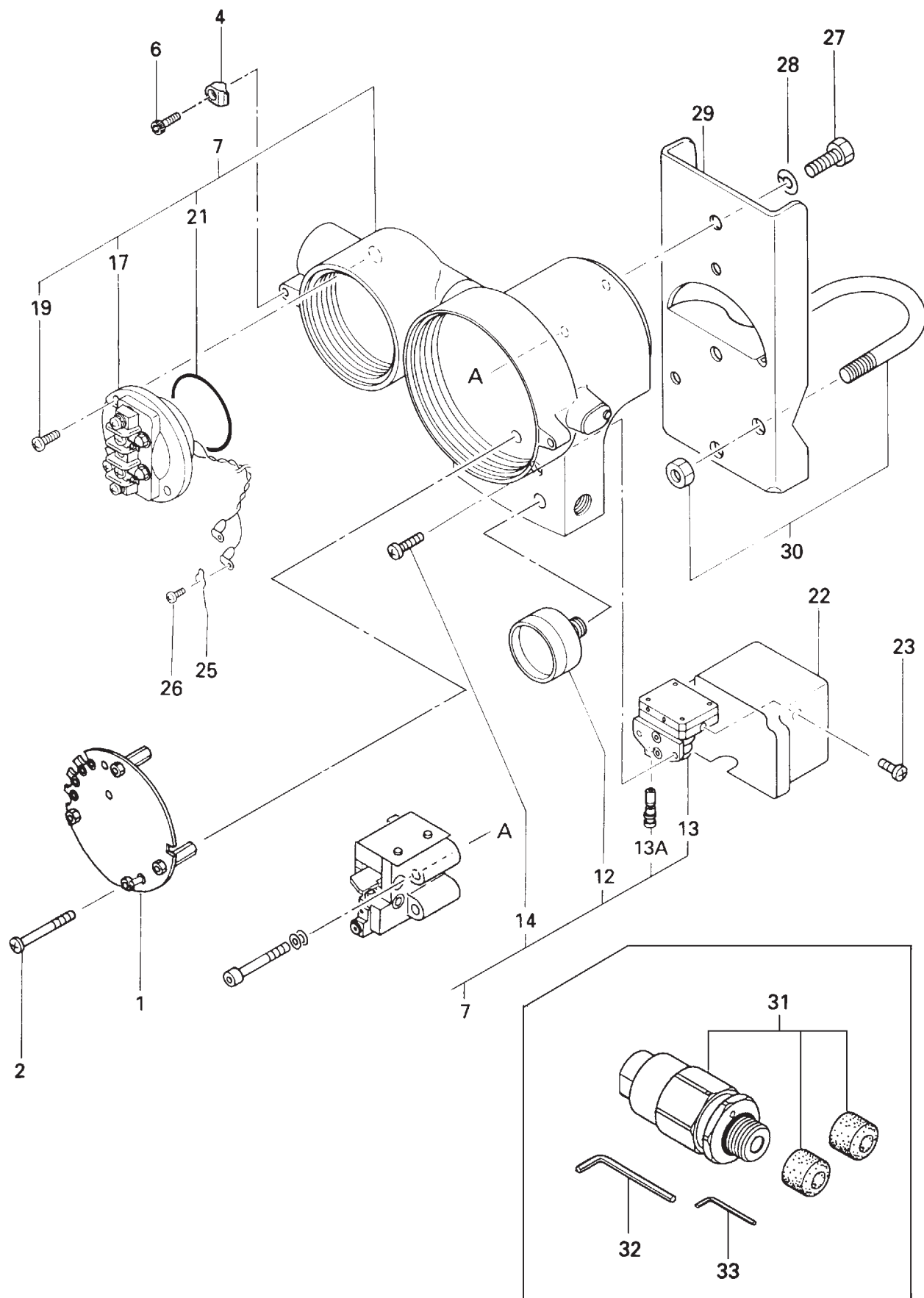

Item	Part No.	Qty								Description
		PK200-A□ ¹ □ ³	PK200-C□ ¹ □ ³	PK200-A□ ² □ ³	PK200-C□ ² □ ³	PK200-A□ ¹ □ ³ /RA	PK200-C□ ¹ □ ³ /RA	PK200-A□ ² □ ³ /RA	PK200-C□ ² □ ³ /RA	
1	See Table 1	1	1	1	1	1	1	1	1	Amplifier Assembly
2	Y9430JB	4	4	4	4	4	4	4	4	Machine Screw, M4×30
4	G9339AA	2	2	2	2	2	2	2	2	Bracket ^{*7}
6	Y9408ZU	2	2	2	2	2	2	2	2	Hex soc. H.Cap Screw, M4×8 ^{*7}
7	—	1	1	1	1	1	1	1	1	Case Assembly
12	See Table 2	2	2	2	2	2	2	2	2	Pressure Gauge (see page 4)
13	F9174HA	1	1			1	1			Pilot Relay Assembly
	F9174HB			1	1			1	1	Pilot Relay Assembly
13A	F9172FB	1	1	1	1	1	1	1	1	Screw Assembly
14	Y9425JY	2	2	2	2	2	2	2	2	Pan H.Screw, M4×25
17	F9172ST	1	1	1	1	1	1	1	1	Terminal Assembly ^{*4}
	F9172TC	1	1	1	1	1	1	1	1	Terminal Assembly (For /FF1) ^{*5}
	—	1	1	1	1	1	1	1	1	Terminal Assembly (For /CS1) ^{*6}
19	Y9512JU	2	2	2	2	2	2	2	2	Pan H.Screw, M5×12
21	F9172DK	1	1	1	1	1	1	1	1	O-Ring
22	F9174HL	1	1	1	1	1	1	1	1	Cover
23	G9307MQ	2	2	2	2	2	2	2	2	Pan H.Screw, M4×8
25	F9275MK	2	2	2	2	2	2	2	2	Clip
26	Y9306JU	2	2	2	2	2	2	2	2	Pan H.Screw
27	Y9820NS	2	2	2	2	2	2	2	2	Bolt
	Y9820NU	2	2	2	2	2	2	2	2	Bolt (When option code is /SS)
28	Y9800SS	2	2	2	2	2	2	2	2	Spring Washer
	Y9800SU	2	2	2	2	2	2	2	2	Spring Washer (When option code is /SS)
29	F9174HM	1	1	1	1	1	1	1	1	Bracket
	F9174FW	1	1	1	1	1	1	1	1	Bracket (When option code is /SS)
30	D0117XL-A	1	1	1	1	1	1	1	1	U-Bolt/Nut Assembly
31	Below	1	1	1	1	1	1	1	1	Cable Grand Assembly ^{*7}
	G9601AM									For Electrical connection: G1/2 female (option code: /G11)
	G9601AN									For Electrical connection: G3/4 female (option code: /G21)
32	E9135GY	1	1	1	1	1	1	1	1	Wrench (M4) ^{*7}
33	G9625BA	1	1	1	1	1	1	1	1	Wrench (M3) ^{*7}

*1: Suffix code of output signal: 1, 3, 5, 7, A

*2: Suffix code of output signal: 2, 4, 6, 8, 9, B, C

*3: For suffix code details (indicated by □), refer to YOKOGAWA GS sheet.

*4: When optional code is /L, Part No. is F9172SU.

*5: When optional code is /L, Part No. is F9172TD.

*6: Consult Yokogawa local office.

*7: For TIIS Flameproof (option code: /JF3)

Table 1. Amplifier Assembly Part No. (Item 1)

Model	Part No. (S2.06)	Part No. (S2.05)
PK200-A□ ^{*1} □ ^{*3}	F9174XA	F9174MA
PK200-C□ ^{*1} □ ^{*3}	F9174XB	F9174MG
PK200-A□ ^{*2} □ ^{*3}	F9174XC	F9174MH
PK200-C□ ^{*2} □ ^{*3}	F9174XD	F9174MJ
PK200-A□ ^{*1} □ ^{*3} /RA	F9174XE	F9174MK
PK200-C□ ^{*1} □ ^{*3} /RA	F9174XF	F9174ML
PK200-A□ ^{*2} □ ^{*3} /RA	F9174XG	F9174MM
PK200-C□ ^{*2} □ ^{*3} /RA	F9174XH	F9174MN
PK200-A□ ^{*1} □ ^{*3} /CS1	— ^{*4}	— ^{*4}
PK200-A□ ^{*2} □ ^{*3} /CS1	— ^{*4}	— ^{*4}
PK200-A□ ^{*1} □ ^{*3} /RA/CS1	— ^{*4}	— ^{*4}
PK200-A□ ^{*2} □ ^{*3} /RA/CS1	— ^{*4}	— ^{*4}
PK200-A□ ^{*1} □ ^{*3} /JS3	— ^{*4}	— ^{*4}
PK200-A□ ^{*2} □ ^{*3} /JS3	— ^{*4}	— ^{*4}
PK200-A□ ^{*1} □ ^{*3} /RA/JS3	— ^{*4}	— ^{*4}
PK200-A□ ^{*2} □ ^{*3} /RA/JS3	— ^{*4}	— ^{*4}

*1: Suffix code of output signal: 1, 3, 5, 7, A

*2: Suffix code of output signal: 2, 4, 6, 8, 9, B, C

*3: For suffix code details, refer to GS sheet.

*4: Consult Yokogawa local office.

Table 2. Pressure Gauge Part No. (Item 12)

Part No.	Output signal code	Air Connection
G9615AT	3	R 1/8
G9615AR	4	R 1/8
G9615EA	1, A	R 1/8
G9615ED	2, B, C	R 1/8
G9615EC	5	R 1/8
G9615EF	6	R 1/8
G9615EB	7	1/8-27 NPT
G9615EE	8, 9	1/8-27 NPT

Revision Information

- Title : PK200
Current-to-Pneumatic Converter
- Manual No. : IM 21B03D01-01E

Edition	Date	Revised Item
4th	Feb. 1996	Style change (Style: S1→Style: S2) other correction. Note CMPL 21B3D1-01E Amplifier Assembly of S2 is not compatible with S1.
5th	Sep. 1996	Installation and Operating Precautions for JIS Flameproof Equipment (B0006) updated and moved to the end of the manual. Due to Terminal box shape modification, Figure 2.2, 2.4, 4.1, 4.4 are changed. 1.1 Data plates for FM Explosionproof Type and CSA Intrinsically Safe Type added. 1.5 Installation of Intrinsically Safe Type added. 1.5.1 CSA Intrinsically Safe (/CS1) added. 1.6 Installation of Flameproof Type added. 1.6.1 JIS Flameproof Type added. 1.6.2 FM Explosionproof Type revised. NEMA 4 → NEMA 4X CMPL Figure of terminal box changed. Item 17, 19 revised. Item 18, 20 deleted. Note *4 revised. *5, *6 added.
6th	July 1997	2.4 Option Code/B added.s CMPL Option Code/B added. Item 1 revised.
7th	Mar. 1998	1.1 Add precaution for safety 4.1 Add precaution for safety 4.4 Add precaution for safety 5.4 Add precaution for safety 5.8 Add precaution for safety
8th	June 1999	Format change Add 'INTRODUCTION' Update Installation and Operating Precautions for JIS Flameproof Equipment (Ex-B02) 2.2 Change 'Exd II B+H ₂ T6' to 'Exd II B+H ₂ T6X' 2.4 Add optional code /JF3, /G11, and /G21 and delete /JF1 and /JF2 4.2 Add warning Change part number in Table 4.2 and Figure 4.3 CMPL Update CMPL 21B3D1-01E
9th	Jan. 2000	1.2 Add Figure 1.3 Add 1.5.2 CENELEC (KEMA) Intrinsically Safe Type Add 1.5.3 JIS Intrinsically Safe Type 2.2 Add information for /KS1 and /JS3 2.4 Add codes /KS1 and /JS3, and delete code /B Add 4.3 Intrinsically Safe Type Wiring Add Ex-A03E Ex-B03E: Change name (from EX-B02E) and format CMPL Update CMPL 21B3D1-01E
10th	Apr. 2001	1.5.3 Move Table from page 4.6. 2.5 Correct terminal configuration diagram. CMPL Table.1 Change parts number.

Edition	Date	Revised Item
11th	Dec. 2007	INTRODUCTION Add caution for prohibition of modification 1-1 JIS → TIIS 1-3 JIS → TIIS 1-4 Add "1.7 EMC Conformity standard" 2-1 JIS → TIIS, Delete CENELEC intrinsically safe type Change Span Adjusting Range Change Water Proof Construction 2-2 JIS → TIIS, Delete CENELEC intrinsically safe type 2-3 Add note for /X1 2-4 Change Figure 2.4 4-2 JIS → TIIS 5-1 Change pressure gauge minimum unit 5-3 Change Figure 5.3 5-4 Change Table 5.7 and Figure 5.4 6-1 Add caution for explosion type 6-2 Add "6.3.3 Replacing the Amplifier Assembly" CMPL P.1: Item 3 change Parts No. P.3: Item 17 delete F9172TE P.3: Item 30 change Parts No. and note P.4: Change Table 1 and Table 2.
12th	Aug. 2012	1-4 Change EMC conformity standard 2-1 Change operating voltage 2-2 Add certificate No. Change water proof construction 5-1 Change description (3) CMPL Revise *1 and *2
13th	July 2015	1 Add TIIS intrinsically safe equipment 1.7 Modify EMC Conformity Standard 2.2 Correct equivalent circuit Correct output signals 4.1.2 Change SUP → IN 4.2.2 Delete (6) 4.3 Figure 4.5 Air supply → Supply air pressure